

TOLON

Operating Manual

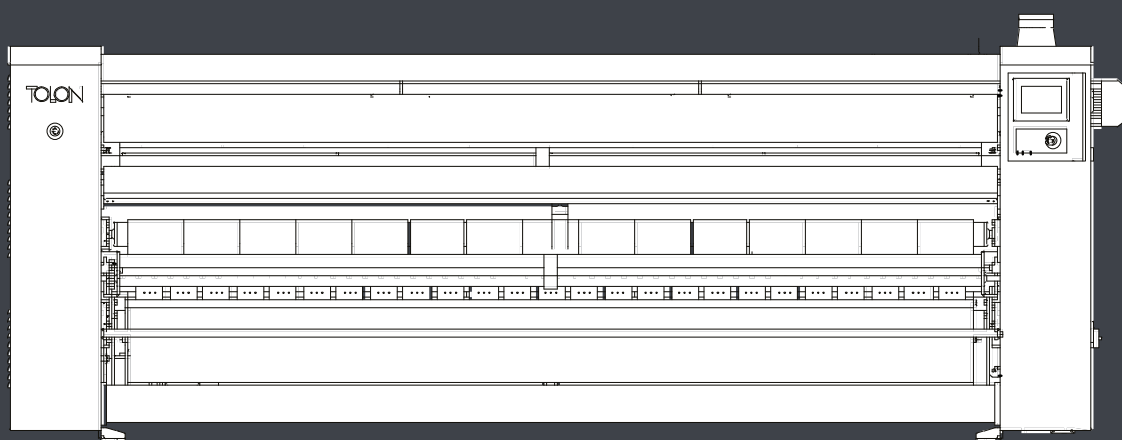

TFI3516 | TFI3521

TFI6026 | TFI6032

Table of Contents

| | |
|--|-----------|
| MACHINE DATASHEET TFI6026 / TFI6032..... | 6 |
| MACHINE DATASHEET TFI3516 / TFI3521..... | 9 |
| EXTERIOR COMPONENTS AND DIMENSIONS DIAGRAMS | 11 |
| TFI6026 / TFI6032 Exterior Components and Dimensions for Standard Models..... | 11 |
| TFI6026 / TFI6032 Exterior Components and Dimensions for Rear Exit Models..... | 12 |
| TFI3516 / TFI3521 Exterior Components and Dimensions for Standard Models..... | 13 |
| WARRANTY AND SERVICE..... | 14 |
| WARRANTY AND SERVICE INSTRUCTIONS..... | 14 |
| Warranty Limited To Parts Only | 14 |
| What This Limited Warranty Covers and for How Long | 14 |
| Limited Warranty Coverage Overview | 14 |
| Warranty Transfer..... | 14 |
| Freight Damaged Product..... | 14 |
| OUT OF WARRANTY TERMS AND CONDITIONS | 14 |
| WARRANTY PROCEDURE UPON DELIVERY..... | 15 |
| SAFETY INFORMATION..... | 16 |
| EXPLANATION OF SAFETY MESSAGES | 16 |
| FUNDAMENTAL SAFETY PRECAUTIONS..... | 16 |
| EMERGENCY STOP BUTTON..... | 16 |
| BASIC PRECAUTIONS..... | 17 |
| WHAT TO DO IF GAS IS SMELLED? (ONLY FOR GAS HEATED MODELS)..... | 20 |
| SAFETY LABELS ON THE PRODUCT..... | 21 |
| Prohibited Signs | 21 |
| Safety Critical Signs..... | 21 |
| Hazard Signs..... | 21 |
| LABEL TEXT SECTIONS..... | 22 |
| Sign Level Indicator | 22 |
| Label Naming Scheme..... | 22 |
| LOCATION OF THE LABELS ON THE 60xx MODELS..... | 23 |
| LOCATION OF THE LABELS ON THE 35xx MODELS..... | 24 |
| HANDLING AND TRANSPORTATION LABELS | 25 |
| IMPORTANT INSTRUCTIONS FOR USE AND PRESERVATION | 26 |
| INTENDED USE OF THE MACHINE AND INAPPROPRIATE USE.. | 26 |
| EXPECTED MACHINE USE and DON'TS | 26 |
| INADVISABLE USE | 26 |
| PROTECTION, SAFETY AND CONTROL ELEMENTS | 27 |
| Safety Guards..... | 27 |
| Switch Breaker | 27 |
| Emergency Stop Button | 27 |
| Hand Protection Guard (Movable Guard with Locking Device) | 27 |
| Temperature Probes..... | 27 |
| Electric Circuit Safety Measures | 27 |
| Pressure Switch of Maximum Pressure..... | 28 |
| Safety Thermostat..... | 28 |
| Safety when Starting the Flatwork Ironer | 28 |
| Heating System Start-up Safety Feature | 28 |
| Flame Control..... | 28 |
| Ignition Delay | 28 |
| RECEIPT | 29 |
| STORAGE..... | 29 |
| RECEPTION AND STORAGE..... | 29 |
| HANDLING AND TRANSPORTATION | 30 |
| MOVING WITH A CRANE | 30 |
| MOVING WITH A FORKLIFT | 30 |
| MOVING WITH A PALLET TRUCK..... | 31 |
| INSTALLATION AND START UP..... | 32 |
| INSTALLATION, POSITIONING AND LOCATION WARNINGS..... | 32 |
| GENERAL INSTALLATION AND LOCATION INFORMATION | 33 |
| ENVIRONMENTAL CONDITIONS..... | 33 |
| INSTALLATION OF THE PRODUCT | 34 |
| INSTALLATION CLEARANCES..... | 34 |
| Installation Clearances for standard TFI3516, TFI3521, TFI6026 and TFI6032 models..... | 34 |
| Installation Clearances for rear exit TFI6026 and TFI6032 models..... | 35 |
| LOCATION REQUIREMENTS..... | 36 |
| ROOM VENTILATION CONDITIONS..... | 37 |
| Ventilation Openings for Electric Heated Models..... | 37 |
| Ventilation Openings for Gas Heated Models | 38 |
| Size of the A1 and A2 openings..... | 38 |
| Position of the A1 and A2 openings | 38 |
| LEVELING OF THE MACHINE | 39 |
| FEET ADJUSTMENT..... | 39 |
| Specifications for the ducting..... | 40 |
| Assembling the exhaust ducting | 41 |
| ELECTRICAL CONNECTIONS | 42 |
| CABLE AND FUSE VALUES OF THE 60XX SERIES..... | 42 |
| CABLE AND FUSE VALUES OF THE 35XX SERIES..... | 43 |
| Installation Instructions for Steam Supply Lines and Steam Return Lines | 44 |
| STEAM CONNECTIONS (ONLY STEAM HEATED MACHINES)..... | 45 |
| Gas Supply | 46 |
| INITIAL START UP OF THE MACHINE | 47 |
| INITIAL CHECKS..... | 47 |
| GAS PRESSURE CONTROL ON GAS MODELS | 47 |
| ANALYSIS OF THE COMBUSTION GASES ON GAS MODELS..... | 48 |
| Changing the position of the air extraction adjustment clapper valve..... | 48 |
| STARTUP INSTRUCTIONS..... | 49 |
| 1. Startup Screen Step..... | 49 |
| 2. Hand Protection Guard Check Step..... | 49 |
| CONTROL PANEL INSTRUCTIONS | 49 |
| MAIN MENU WINDOW..... | 50 |
| USER INTERFACE..... | 51 |
| States of Buttons | 51 |
| States of the Burner State Icon | 51 |
| MAIN MENU INSTRUCTIONS | 52 |
| 1. LANGUAGE SELECTION MENU | 52 |
| To set the interface language : | 52 |
| 2. QUICK START BUTTON / PROGRAM EXECUTION WINDOW | 53 |
| 2.1 PROGRAM EXECUTION WINDOW INSTRUCTIONS..... | 55 |
| 2.2 PROGRAM OPTIONS | 55 |
| 2.2.1 Program Name | 55 |
| 2.2.2 Ironing Speed..... | 55 |
| 2.2.2.1 Notes on Ironing Speed..... | 55 |
| 2.2.3 Roller Temperature..... | 56 |
| 2.2.4 Folding Mode | 56 |
| 2.2.4.1 Linen Fold-Length Table and Graphs | 58 |
| 2.2.5 Non-Folding Mode | 60 |
| 2.3 PROGRAM MODIFICATION..... | 60 |
| 2.3.1 Saving A Program..... | 60 |

Table of Contents

| | |
|---|-----------|
| 2.4 PROGRAM EXECUTION..... | 61 |
| 3. PROGRAMS MENU | 61 |
| 4. ALARMS MENU..... | 62 |
| 5. BRIGHTNESS AND DATE MENU..... | 62 |
| 5.1 Brightness Setting Window..... | 62 |
| 5.2 Date/Time Setting Window..... | 63 |
| 6. SERVICE MENU | 63 |
| 6.1 I/O LINK MENU | 64 |
| 6.1.1 Digital Inputs Window | 64 |
| 6.1.2 Digital Outputs Window..... | 65 |
| 6.2 PARAMETERS MENU | 66 |
| Setup Parameters..... | 66 |
| 6.2.1 Setup Parameters Section..... | 66 |
| 6.2.1.1 Setup Parameters 1 Window | 66 |
| 6.2.1.2 Setup Parameters 2 Window | 67 |
| 6.2.1.3 Setup Parameters 3 Window | 67 |
| 6.2.2 Burner Parameters Section | 68 |
| 6.2.2.1 Temperature Sensors Window | 68 |
| 6.2.2.2 Burner PID Parameters Window | 69 |
| 6.2.3 Clutch Parameters Window | 70 |
| 6.2.4 Folding Parameters Section | 71 |
| 6.2.4.1 Auto Fold Parameters Window | 71 |
| 6.2.4.2 Manual Folder Parameters Window | 71 |
| 6.2.4.3 Cylinder Movement Correction Parameters Window | 72 |
| 6.2.4.4 Duration of Cylinder Movement Parameters Window | 72 |
| 6.3 MANUEL CONTROL WINDOW..... | 73 |
| SYSTEM ALARMS..... | 74 |
| NOTES..... | 75 |
| Notes 1: Burner Parameters List..... | 75 |
| Notes 2: Clutch Parameters List | 76 |
| Notes 3: Folding Parameters List | 77 |
| Notes 4: Digital and Analog I/O Lists..... | 78 |
| PERSONAL PROTECTION WEAR..... | 79 |
| UNEXPECTED INTERRUPTION OF THE POWER SUPPLY . | 80 |
| | 80 |
| PROTECTION AGAINST BURNT LINEN AND IRONING STRAPS | 80 |
| USAGE OF THE CRANK HANDLE ON THE 60XX SERIES..... | 81 |
| Handle Decoupling..... | 81 |
| USAGE OF A RING SPANNER ON THE 35XX SERIES | 81 |
| PROLONGED STOPPAGES | 81 |
| FREEDING A TRAPPED PERSON | 82 |
| RECOVERY PROCEDURE TO FOLLOW IN THE EVENT OF AN ENTRAPMENT..... | 82 |
| SECURITY INFORMATION | 83 |
| END OF SHIFT INSTRUCTIONS..... | 83 |
| DAILY MAINTENANCE..... | 83 |
| WEEKLY MAINTENANCE | 83 |
| MONTHLY MAINTENANCE | 83 |
| QUARTERLY MAINTENANCE | 83 |
| MAINTENANCE AND SERVICE..... | 83 |
| DEHUMIDIFIER MAINTENANCE..... | 84 |
| CALLING A SERVICE..... | 84 |
| DISPOSAL OF UNIT..... | 85 |
| ENVIRONMENTAL..... | 85 |
| INDEX..... | 86 |
| FIGURE INDEX..... | 86 |
| TABLE INDEX..... | 87 |
| PHOTO INDEX..... | 87 |

MANUFACTURER INFORMATION**MANUFACTURER**

Tolon Global Makine San. ve Tic. A.Ş.

ADDRESS

10007 Sokak No:9 35620 A.O.S.B. Çiğli-İzmir/TÜRKİYE

TELEPHONE

+90 (232) 376 70 84 (pbx)

FAX

+90 (232) 376 70 89

WEB

<http://www.tolon.com>

E-MAIL

tolon@tolon.com

HELPDESK

help@tolon.com

SPARE PARTS

parts@tolon.com

MACHINE DATASHEET TFI6026 / TFI6032

| | Unit | TFI6026 | TFI6032 |
|---|--------------------|---------|---------|
| Capacity | | | |
| Performance ¹² (Min-Max) with Pneumatic Folding option | kg/h | 90-105 | 110-130 |
| | lb/h | 198-231 | 242-286 |
| Performance ¹² (Min-Max) with Electrical Folding option | kg/h | 145-162 | 180-200 |
| | lb/h | 319-357 | 397-441 |
| Roller | | | |
| Diameter | mm | 600 | 600 |
| | in | 23,62 | 23,62 |
| Working Width | mm | 2600 | 3200 |
| | in | 102,36 | 126 |
| Roller Speed | m/min | 3,5-12 | 3,5-12 |
| | in/min | 138-472 | 138-472 |
| Electric | | | |
| Electric Heating Power ³ | kW | 56 | 69 |
| | Btu | 191000 | 235000 |
| Evaporation Rate | l/h | 65 | 80 |
| | gal/h | 17 | 21 |
| | ft ³ /h | 2,2 | 2,8 |
| Electric Consumption | kW/h | 57,8 | 71 |
| | Btu/h | 197000 | 242000 |
| Electric Rating | | | |
| Roller Motor | kW | 0,75 | 0,75 |
| | hp | 1,019 | 1,019 |
| Fan Motor | kW | 1,1 | 1,1 |
| | hp | 1,49 | 1,49 |

¹ 50% moisture

² Output calculated for: Pneumatic Folding option at 6 m/min / Electrical Folding option at 9m/min

³ Output calculated at 380V / 3 phase

| | Unit | TFI6026 | TFI6032 |
|--|--------------------|-----------|-----------|
| Gas | | | |
| Gas Heating Power | kW | 65 | 80 |
| | Btu | 221700 | 272900 |
| Evaporation Rate with Pneumatic Folding option | l/h | 50 | 60 |
| | gal/h | 13,2 | 15,8 |
| | ft ³ /h | 1,76 | 2,11 |
| Evaporation Rate with Electrical Folding option | l/h | 80 | 100 |
| | gal/h | 21,1 | 26,4 |
| | ft ³ /h | 2,83 | 3,52 |
| Gas Connection Φ | DN | 20 | 20 |
| | BSP | ¾" | ¾" |
| Gas Pressure Natural Gas | mbar | 20-60 | 20-60 |
| | psi | 0,30-0,87 | 0,30-0,87 |
| Gas Pressure LPG | mbar | 20-60 | 20-60 |
| | psi | 0,30-0,87 | 0,30-0,87 |
| Gas Consumption Natural Gas | m ³ /h | 5,3 | 8,3 |
| | ft ³ /h | 187 | 293 |
| | kW/h | 65 | 80 |
| | Btu/h | 221700 | 272900 |
| Gas Consumption LPG | m ³ /h | 2,5 | 3,1 |
| | ft ³ /h | 88 | 109 |
| | kW/h | 65 | 80 |
| | Btu/h | 221700 | 272900 |
| Air | | | |
| Air Connection Φ | mm | 10 | 10 |
| | in | 0,4 | 0,4 |
| Air Consumption | l/min | 50 | 50 |
| | gal/min | 13,2 | 13,2 |
| Air Pressure (Min-Max) | bar | 4-6 | 4-6 |
| | psi | 58-87 | 58-87 |
| Exhaust | | | |
| Exhaust Connection Φ | mm | 125 | 125 |
| | in | 4,9 | 4,9 |
| Airflow Electric Heated Models | m ³ /h | 1125 | 1125 |
| | ft ³ /h | 39729 | 39729 |
| Airflow Gas Heated Models | m ³ /h | 1125 | 1125 |
| | ft ³ /h | 39729 | 39729 |

| | Unit | TF16026 | TF16032 |
|---|-------|--------------------------|------------------------|
| Dimensions | | | |
| Unpacked Standard Models (WxDxH) All Heating Types / All Folding Types | mm | 3552 x 1351 x 1598 | 4152 x 1351 x 1598 |
| | in | 139,8 x 53,18 x 62,91 | 163,46 x 53,18 x 62,91 |
| Unpacked Rear Exit Models (WxDxH) All Heating Types / All Folding Types | mm | 3552 x 1647 x 1598 | 4152 x 1647 x 1598 |
| | in | 139,8 x 64,84 x 62,91 | 163,46 x 64,84 x 62,91 |
| Packed Standard Models (WxDxH) All Heating Types / All Folding Types | mm | 3650 x 1500 x 1758 | 4250 x 1500 x 1758 |
| | in | 143,7 x 59 x 69,21 | 167,32 x 59 x 69,21 |
| Packed Rear Exit Models (WxDxH) All Heating Types / All Folding Types | mm | 3650 x 1800 x 1758 | 4250 x 1800 x 1758 |
| | in | 143,7 x 70,87 x 69,21 | 167,32 x 70,87 x 69,21 |
| Weight | | | |
| Machine Net Weight Standard Models with Folder Electric Heated Models | kg | 1825 | 2010 |
| | lb | 4023 | 4431 |
| Machine Net Weight Standard Models with Folder Gas Heated Models | kg | 1775 | 1950 |
| | lb | 3913 | 4230 |
| Machine Net Weight Standard Models without Folder Electric Heated Models | kg | 1700 | 1910 |
| | lb | 3747 | 4210 |
| Machine Net Weight Standard Models without Folder Gas Heated Models | kg | 1675 | 1850 |
| | lb | 3693 | 4079 |
| Machine Net Weight Rear Exit Models All Heating Types | kg | 1850 | 2060 |
| | lb | 4079 | 4542 |
| Machine Gross Weight Standard Models with Folder Electric Heated Models | kg | 2025 | 2210 |
| | lb | 4464 | 4872 |
| Machine Gross Weight Standard Models with Folder Gas Heated Models | kg | 1925 | 2160 |
| | lb | 4245 | 4762 |
| Machine Gross Weight Standard Models without Folder Electric Heated Models | kg | 1875 | 2050 |
| | lb | 4133 | 4520 |
| Machine Gross Weight Standard Models without Folder Gas Heated Models | kg | 1850 | 2025 |
| | lb | 4079 | 4464 |
| Machine Gross Weight Rear Exit Models All Heating Types | kg | 2050 | 2250 |
| | lb | 4519 | 4960 |
| Sound Pressure | | | |
| Sound Level | db(A) | < 65,6 | < 65,6 |
| Environmental Conditions | | | |
| Ambient Temperature | °C | 5 to 40 | |
| | °F | 41 to 104 | |
| Relative Humidity | % | 80% without condensation | |
| Height Above Sea Level | m | up to 3000 | |
| | ft | up to 10000 | |
| Vibrations | - | free | |
| Lighting Level | - | min. 300 lux | |

MACHINE DATASHEET TFI3516 / TFI3521

| | Unit | TFI3516 | TFI3521 |
|---------------------------------------|--------------------|---------|---------|
| Capacity | | | |
| Performance ¹ | kg/h | 68 | 85 |
| | lb/h | 150 | 187 |
| Roller | | | |
| Diameter | mm | 350 | 350 |
| | in | 13,78 | 13,78 |
| Working Width | mm | 1640 | 2100 |
| | in | 62,99 | 82,68 |
| Roller Speed | m/min | 2-6 | 2-6 |
| | ft/min | 39-236 | 39-236 |
| Electric | | | |
| Electric Heating Power | kW | 24 | 30 |
| Evaporation Rate | l/h | 18 | 25 |
| | gal/h | 4,75 | 6,6 |
| | ft ³ /h | 0,16 | 0,23 |
| Electric Consumption | kW/h | 24 | 30 |
| Gas | | | |
| Gas Heating Power | kW | 28 | 37 |
| | Btu | 95500 | 126200 |
| Evaporation Rate | l/h | 26 | 34 |
| | gal/h | 6,87 | 8,98 |
| Gas Connection Φ | DN | 20 | 20 |
| | BSP | ¾" | ¾" |
| Gas Pressure (Min-Max) Natural Gas | mbar | 20-60 | 20-60 |
| | psi | 0,3-0,9 | 0,3-0,9 |
| Gas Pressure (Min-Max) LPG | mbar | 20-60 | 20-60 |
| | psi | 0,3-0,9 | 0,3-0,9 |
| Gas Consumption Natural Gas | m ³ /h | 2,9 | 3,8 |
| | ft ³ /h | 102 | 134 |
| | cu yd/h | 3,8 | 4,9 |
| | kW/h | 28 | 37 |
| | Btu/h | 95500 | 126200 |
| Gas Consumption LPG | m ³ /h | 1 | 1,4 |
| | ft ³ /h | 35 | 49 |
| | cu yd/h | 1,3 | 1,8 |
| | kW/h | 28 | 37 |
| | Btu/h | 95500 | 126200 |
| Electric Consumption | kW/h | 1,5 | 1,5 |

| | Unit | TFI3516 | TFI3521 |
|--|--------------------|--------------------------|---------------------|
| Electric Rating | | | |
| Roller Motor | kW | 0,37 | 0,37 |
| | hp | 0,5 | 0,5 |
| Fan Motor | kW | 0,75 | 0,75 |
| | hp | 1 | 1 |
| Exhaust | | | |
| Exhaust Connection Φ | mm | 110 | 110 |
| | in | 4,33 | 4,33 |
| Airflow Electric Heated Models | m ³ /h | 450 | 450 |
| | ft ³ /h | 15892 | 15892 |
| Airflow Gas Heated Models | m ³ /h | 450 | 450 |
| | ft ³ /h | 15892 | 15892 |
| Dimensions | | | |
| Standard (WxDxH) Electric Heated Models | mm | 2554 x 759 x 1251 | 2974 x 759 x 1251 |
| | in | 100,6 x 29,9 x 49,3 | 117,1 x 29,9 x 49,3 |
| Standard (WxDxH) Gas Heated Models | mm | 2554 x 775 x 1251 | 2974 x 775 x 1251 |
| | in | 100,6 x 30,5 x 49,3 | 117,1 x 30,5 x 49,3 |
| Packing (WxDxH) Electric Heated Models | mm | 2640 x 900 x 1391 | 3060 x 900 x 1391 |
| | in | 103,9 x 35,4 x 54,8 | 120,5 x 35,4 x 54,8 |
| Packing (WxDxH) Gas Heated Models | mm | 2640 x 900 x 1391 | 3060 x 900 x 1391 |
| | in | 103,9 x 35,4 x 54,8 | 120,5 x 35,4 x 54,8 |
| Weight | | | |
| Machine Net Weight Electric Heated Models | kg | 725 | 800 |
| | lb | 1598 | 1763 |
| Machine Net Weight Gas Heated Models | kg | 650 | 735 |
| | lb | 1433 | 1620 |
| Machine Gross Weight Electric Heated Models | kg | 765 | 890 |
| | lb | 1687 | 1962 |
| Machine Gross Weight Gas Heated Models | kg | 690 | 795 |
| | lb | 1521 | 1753 |
| Sound Pressure | | | |
| Sound Level | db(A) | < 60 | < 60 |
| Environmental Conditions | | | |
| Ambient Temperature | °C | 5 to 40 | |
| | °F | 41 to 104 | |
| Relative Humidity | % | 80% without condensation | |
| Height Above Sea Level | m | up to 3000 | |
| | ft | up to 10000 | |
| Vibrations | - | free | |
| Lighting Level | - | min. 300 lux | |

¹ 50% moisture

EXTERIOR COMPONENTS AND DIMENSIONS DIAGRAMS

TFI6026 / TFI6032 Exterior Components and Dimensions for Standard Models

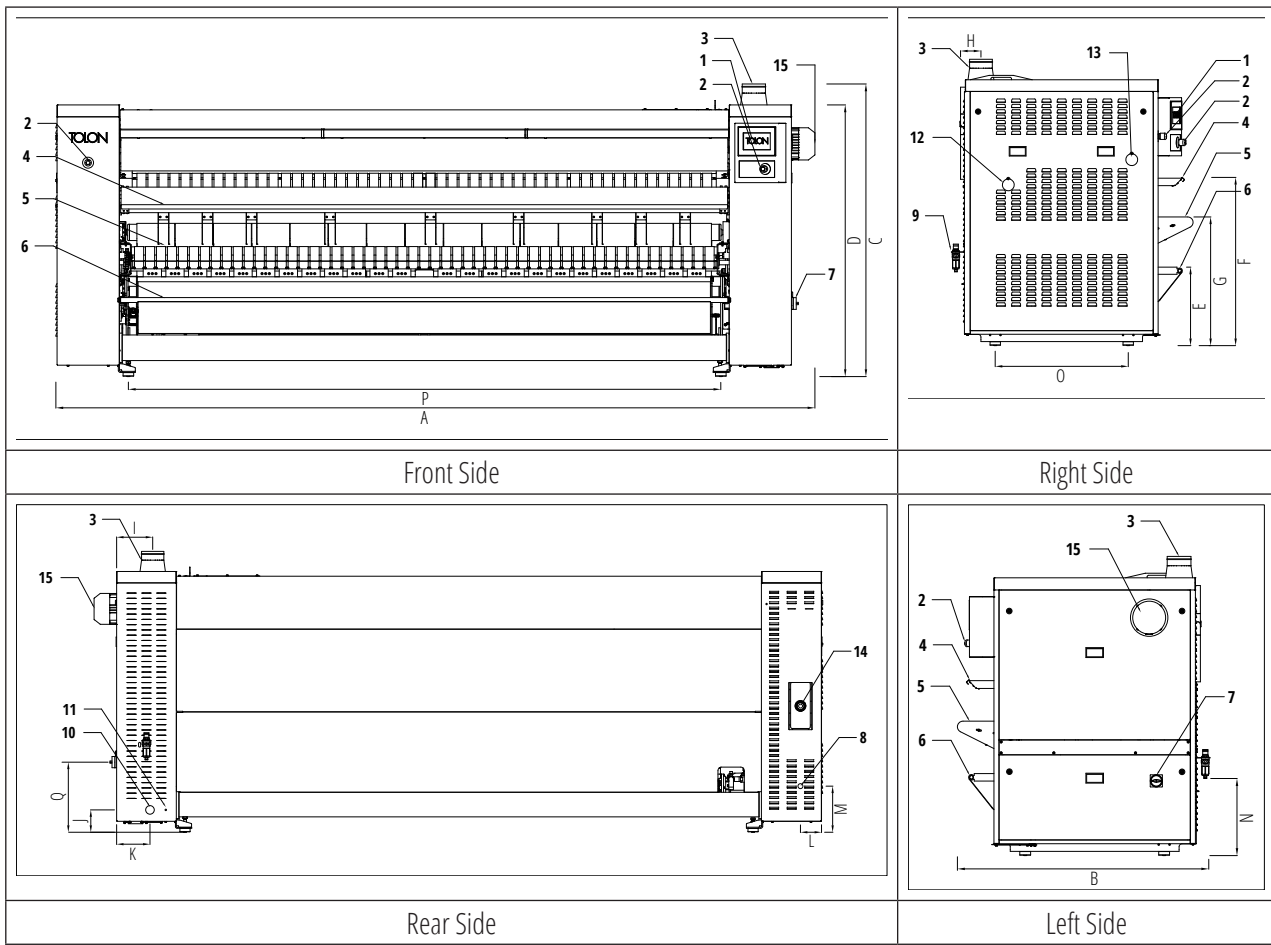

Fig. 1 Front, rear, right and left side view diagrams of TFI6026 / TFI6032 standard models

| | | | | |
|--------------------------|----------------------------|-------------------|-----------------------------|-----------------------------|
| 1. Control Panel | 4. Preparation Tray | 7. Power Switch | 10. Electric Connection | 13. Manual Driving Hole |
| 2. Emergency Stop Button | 5. Folder Outlet | 8. Gas Connection | 11. Grounding Connection | 14. Burner Air Inlet Filter |
| 3. Exhaust Outlet | 6. Retractable Output Tray | 9. Air Regulator | 12. Burner Observation Hole | 15. Fan Motor |

Table 1 Components of the front, rear, right and left side view diagrams of TFI6026 / TFI6032 standard models

| Dimensions TFI6026 Standard | | | | | | | | | | | | | | | | | |
|-----------------------------|-------|------|------|------|------|-----|------|-----|-----|-----|-----|-----|------|------|------|-------|------|
| Unit | A | B | C | D | E | F | G | H | I | J | K | L | M | N | O | P | Q |
| mm | 3552 | 1346 | 1600 | 1486 | 439 | 940 | 719 | 114 | 208 | 129 | 192 | 122 | 266 | 417 | 743 | 2646 | 400 |
| in | 139,8 | 52,9 | 62,9 | 58,5 | 17,3 | 37 | 28,3 | 4,5 | 8,2 | 5,1 | 7,5 | 4,8 | 10,4 | 16,2 | 29,2 | 104,2 | 15,7 |
| Dimensions TFI6032 Standard | | | | | | | | | | | | | | | | | |
| Unit | A | B | C | D | E | F | G | H | I | J | K | L | M | N | O | P | Q |
| mm | 4152 | 1346 | 1600 | 1486 | 439 | 940 | 719 | 114 | 208 | 129 | 192 | 122 | 266 | 417 | 743 | 3240 | 400 |
| in | 163,4 | 52,9 | 62,9 | 58,5 | 17,3 | 37 | 28,3 | 4,5 | 8,2 | 5,1 | 7,5 | 4,8 | 10,4 | 16,2 | 29,2 | 127,5 | 15,7 |

Table 2 Length values for TFI6026 / TFI6032 standard model diagrams

TFI6026 / TFI6032 Exterior Components and Dimensions for Rear Exit Models

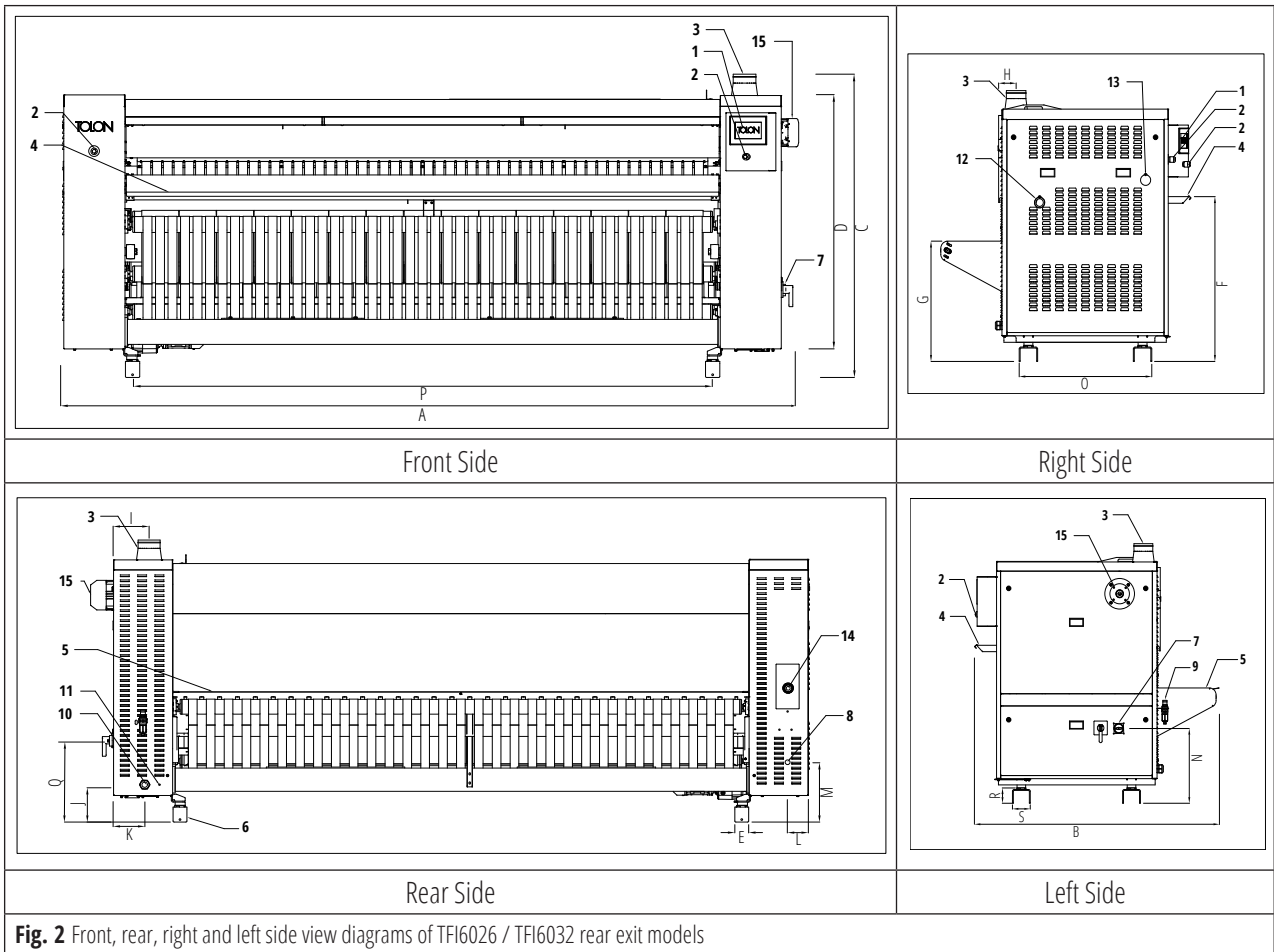

Fig. 2 Front, rear, right and left side view diagrams of TFI6026 / TFI6032 rear exit models

| | | | | |
|--------------------------|---------------------|-------------------|-----------------------------|-----------------------------|
| 1. Control Panel | 4. Preparation Tray | 7. Power Switch | 10. Electric Connection | 13. Manual Driving Hole |
| 2. Emergency Stop Button | 5. Folder Outlet | 8. Gas Connection | 11. Grounding Connection | 14. Burner Air Inlet Filter |
| 3. Exhaust Outlet | 6. Lift Part | 9. Air Regulator | 12. Burner Observation Hole | 15. Fan Motor |

Table 3 Components of the front, rear, right and left side view diagrams of TFI6026 / TFI6032 rear exit models

| Dimensions TFI6026 Rear Exit | | | | | | | | | | | | | | | | | | | |
|------------------------------|-------|------|------|------|-----|------|------|-----|-----|-----|-----|-----|------|------|------|-------|------|-----|-----|
| Unit | A | B | C | D | E | F | G | H | I | J | K | L | M | N | O | P | Q | R | S |
| mm | 3552 | 1646 | 1700 | 1486 | 80 | 1040 | 754 | 114 | 208 | 229 | 192 | 122 | 366 | 517 | 743 | 2646 | 500 | 100 | 120 |
| in | 139,8 | 52,9 | 62,9 | 58,5 | 3,2 | 37 | 28,3 | 4,5 | 8,2 | 5,1 | 7,5 | 4,8 | 10,4 | 16,2 | 29,2 | 104,2 | 15,7 | 4 | 4,7 |

| Dimensions TFI6032 Rear Exit | | | | | | | | | | | | | | | | | | | |
|------------------------------|-------|------|------|------|-----|------|------|-----|-----|-----|-----|-----|------|------|------|-------|------|-----|-----|
| Unit | A | B | C | D | E | F | G | H | I | J | K | L | M | N | O | P | Q | R | S |
| mm | 4152 | 1646 | 1700 | 1486 | 80 | 1040 | 754 | 114 | 208 | 229 | 192 | 122 | 366 | 517 | 743 | 3240 | 500 | 100 | 120 |
| in | 163,4 | 52,9 | 62,9 | 58,5 | 3,2 | 37 | 28,3 | 4,5 | 8,2 | 5,1 | 7,5 | 4,8 | 10,4 | 16,2 | 29,2 | 127,5 | 15,7 | 4 | 4,7 |

Table 4 Length values for TFI6026 / TFI6032 rear exit model diagrams

TFI3516 / TFI3521 Exterior Components and Dimensions for Standard Models

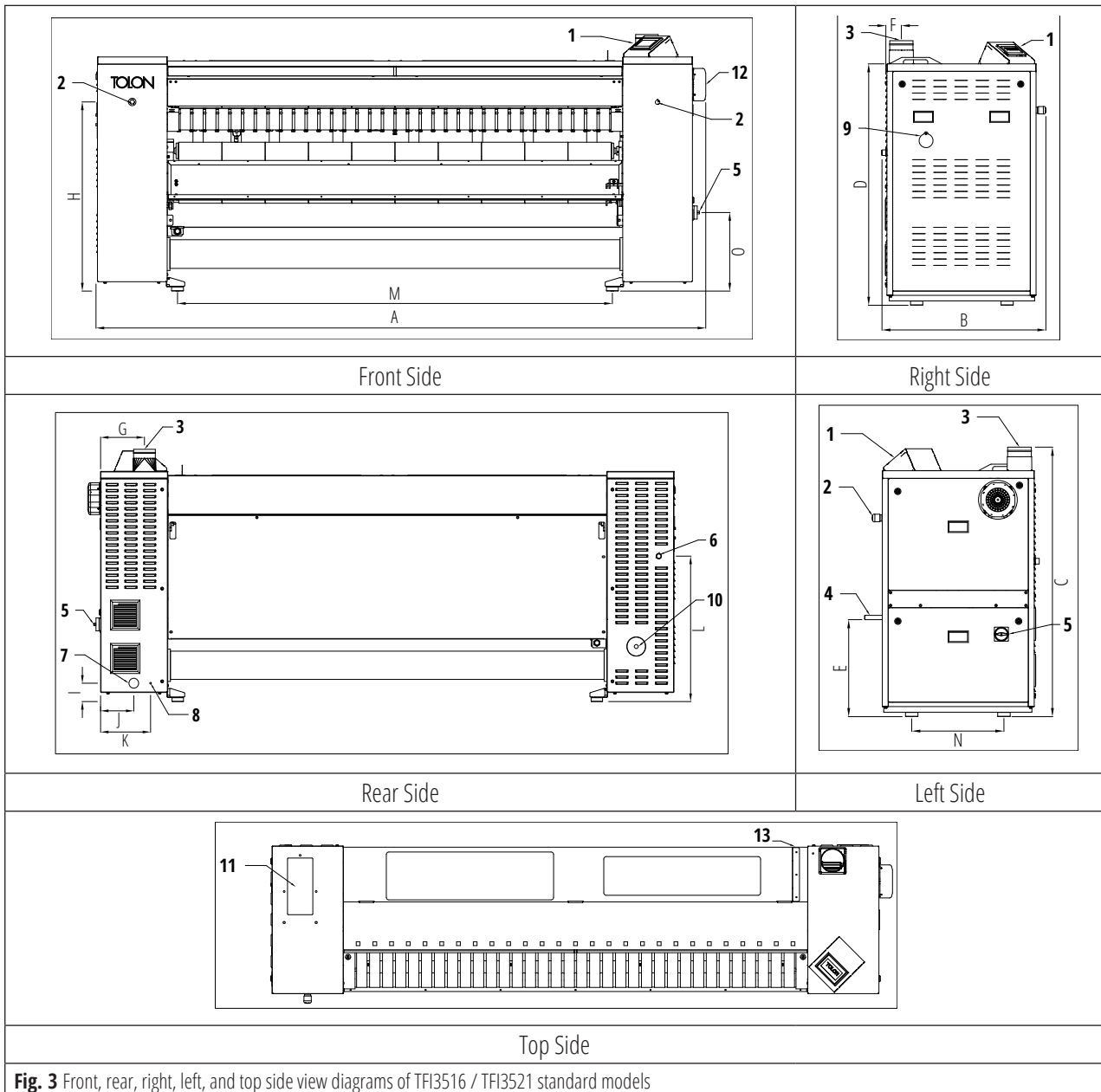

Fig. 3 Front, rear, right, left, and top side view diagrams of TFI3516 / TFI3521 standard models

| | | | | |
|--------------------------|----------------------------|----------------------------|-----------------------------|-------------------|
| 1. Control Panel | 4. Retractable Output Tray | 7. Electric Connection | 10. Manual Driving Hole | 13. Vacuum Filter |
| 2. Emergency Stop Button | 5. Power Switch | 8. Grounding Connection | 11. Burner Air Inlet Filter | |
| 3. Exhaust Outlet | 6. Gas Connection | 9. Burner Observation Hole | 12. Fan Motor | |

Table 5 Components of the front, rear, right, left, and top side view diagrams of TFI3516 / TFI3521 standard models

| Dimensions TFI3516 Standard | | | | | | | | | | | | | | | |
|-----------------------------|-------|------|------|------|------|-----|-----|------|-----|-----|-----|------|------|------|------|
| Unit | A | B | C | D | E | F | G | H | I | J | K | L | M | N | O |
| mm | 2554 | 759 | 1251 | 1142 | 450 | 73 | 222 | 923 | 91 | 168 | 253 | 721 | 1622 | 428 | 383 |
| in | 100,6 | 29,9 | 49,3 | 45 | 17,7 | 2,9 | 8,7 | 36,3 | 3,6 | 6,6 | 10 | 28,4 | 63,9 | 16,9 | 15,1 |
| Dimensions TFI3521 Standard | | | | | | | | | | | | | | | |
| Unit | A | B | C | D | E | F | G | H | I | J | K | L | M | N | O |
| mm | 2974 | 759 | 1251 | 1142 | 450 | 73 | 222 | 923 | 91 | 168 | 253 | 721 | 2121 | 428 | 383 |
| in | 117,1 | 29,9 | 49,3 | 45 | 17,7 | 2,9 | 8,7 | 36,3 | 3,6 | 6,6 | 10 | 28,4 | 83,5 | 16,9 | 15,1 |

Table 6 Length values for TFI3516 / TFI3521 standard model diagrams

WARRANTY AND SERVICE

WARRANTY AND SERVICE INSTRUCTIONS

Warranty Limited To Parts Only

Warranty coverage begins upon initial invoice date regardless of when the unit becomes operational.

What This Limited Warranty Covers and for How Long

The manufacturer will credit, repair or replace free of charge, any part which fails as a result of a structural defect in material during the warranty period of one year.

On each machine, there is a serial plate that states the model and serial number. These information will be the unique key for all further communication. Without this necessary information, all further action for warranty will be voided. The placement of the serial plate is shown on the "Exterior Components and Dimensions Diagrams" section on p.8.

The warranty period on the complete washer extractor is three (3) years.

Limited Warranty Coverage Overview

Warranty coverage begins from the date of invoice, regardless of when the unit is put into operation.

Warranty coverage is limited to product failures which are the result of a defect in material or workmanship. Repairs due to abuse, misuse, transportation damage, improper servicing, by inadequate or improper installation, exposure to the elements, consequential or incidental damages are not covered under this limited warranty.

The limited warranty obligation covers the replacement of defective parts only. Shipping charges are not covered under the terms of the warranty.

The manufacturer does not recommend that conversions which alter the design of the machine should be performed on the equipment. Any such modifications will void the warranty.

Under terms of the distributor's agreement with the manufacturer, all authorized distributors are required to cover any labor for repairs to a customer's equipment for a minimum of 30 days after the installation date.

In the event parts fail under terms of the applicable warranty, credit note will be issued upon receipt of a completed warranty

claim.

The warranty of the parts is either one year or the remaining warranty duration of the complete machine, whichever is longer.



Warranty coverage begins from invoice date, regardless of when a unit is put into operation.

Warranty Transfer

The product warranty on the manufacturer's equipment is not transferable.

Freight Damaged Product

All products are shipped "FOB origin" meaning that loss or damage claims are the responsibility of the buyer. Freight damage is not covered under warranty.

OUT OF WARRANTY TERMS AND CONDITIONS

Faults caused by the user.

Faults caused by using inappropriate products.

Faults caused by plumbing and lime, metal pieces that enter to the laundry and other foreign materials.

Faults of electrical installation.

High voltage, low voltage and sudden voltage changes.

Faults caused by not following warning labels and instructions.

Faults caused by not following the instructions while transporting the product.

Interference by unauthorized personnel.

Using unoriginal spare parts.

The various damages caused by defects which are not reported on time.

Not respecting the maintenance plan according to the manual.

Not sending the Control List to the manufacturer which will be filled out by the authorized personnel.

WARRANTY PROCEDURE UPON DELIVERY

A proper eye examination must be made when the product is delivered. In case of detecting a defect, the warranty procedure must be applied as following before unloading the equipment from the freight.

- 1.** The defected section/s of the product must be photographed from different perspectives.
- 2.** The authorized service contractor must be immediately contacted and it must be ensured that an official report is prepared.
- 3.** The Insurance Company must be informed.

If this procedure cannot be carried out it may cause the product to become OUT OF WARRANTY.

SAFETY INFORMATION

EXPLANATION OF SAFETY MESSAGES

Precautionary statements (“Danger”, “Warning”, and “Caution”), followed by specific instructions, are found in this manual and on machine decals. These precautions are intended for the personal safety of the operator, user, servicer, and those maintaining the machine.





| | |
|---|---|
|  <p>DANGER</p> | <p>DANGER Danger indicates the presence of a hazard that will cause severe personal injury, death, or substantial property damage if the danger is ignored.</p> |
|  <p>WARNING</p> | <p>WARNING Warning indicates the presence of a hazard that can cause severe personal injury, death, or substantial property damage if the warning is ignored.</p> |
|  <p>CAUTION</p> | <p>CAUTION Caution indicates the presence of a hazard that will or can cause minor personal injury or property damage if the caution is ignored.</p> |
|  <p>IMPORTANT</p> | <p>IMPORTANT The word “important” is used to inform the reader of specific procedures where minor machine damage will occur if the procedure is not followed.</p> |
|  <p>NOTE</p> | <p>NOTE The word “note” is used to communicate installation, operation, maintenance or servicing information that is important but not hazard related.</p> |

Table 7 Precautionary Statement Icons and Explanations

FUNDAMENTAL SAFETY PRECAUTIONS

It is critically important to comply with the all safety measures stated in this document!

Unauthorized personnel should not interfere with the machine.

This operation manual must be **read thoroughly** by the operators and persons in charge before operation.

Warnings are present on the machine, on its package and in its manual against unclear potential risks and other kinds of risks.

It must be ensured that the operators of this machine **know the warning signs on the machine** and are qualified to use this machine.

The product must only be used for the intended purpose.

Failure to install and operate this machine according to the instruction handbooks or to work safety and hygiene standards and common sense, may result in conditions which can produce bodily injury or loss of life.

The danger, warning, caution and important instructions appearing in the instruction handbooks are not meant to cover all possible conditions and situations that may occur. It must be understood that common sense, caution and carefullness are factors which cannot be built into this machine. These factors must be supplied by the person(s) transporting, installing, maintaining or operating the machine. Any problems or conditions not understood should be reported to the dealer, distributor, service agent or the manufacturer.

Always put safety first when using the machine.

EMERGENCY STOP BUTTON

The machine is installed with two (2) emergency stop buttons located on the front panel for unusual circumstances. These buttons provide that all the moving parts within the machine come to a sudden halt. All personnel in the company must know the working process of the emergency stop buttons and should be able to use them.

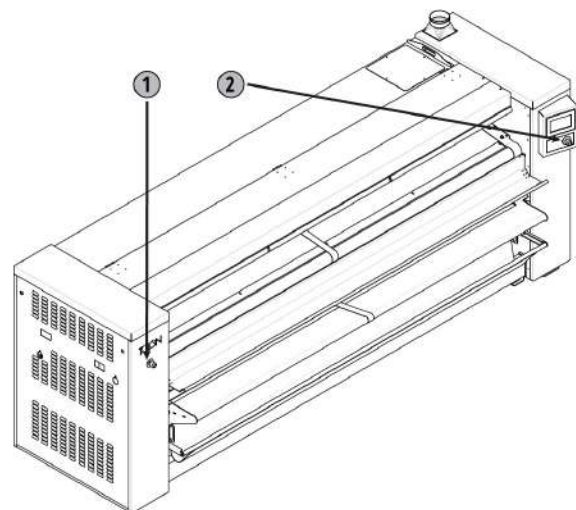

Fig. 4 Emergency Stop Button Locations on TFI6026/TFI6032 models

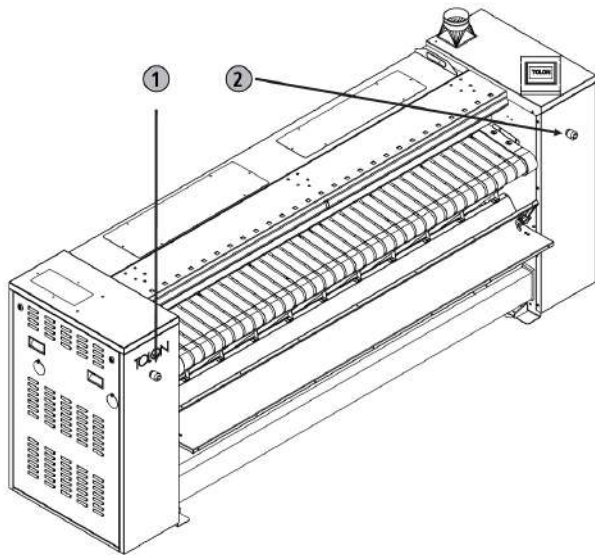

Fig. 5 Emergency Stop Button Locations on TFI3516/TFI3521 models

To operate the emergency stop buttons:

- Press one of the red colored emergency stop buttons to stop all action
- To restart the machine, turn the red colored emergency stop button in the clockwise direction and release it.



NOTE

Activation of the emergency stop button stops all machine control functions, but does not remove all electrical power from the machine.

BASIC PRECAUTIONS

To reduce the risk of **fire, electric shock, serious injury or death** to persons when using the machine, these basic precautions should be followed:



Safety devices should not be bypassed.

The machine should never be started or used in the absence, incorrect position or malfunction of covers, safety guards, safety devices, and control devices.

The room where the machine is located shall comply with the environment conditions (air venting, temperature, humidity, etc) specified in the Machine Datasheet, Dryer Enclosure Requirements and Exhaust Requirements sections of the Flatwork Ironer Operating Manual. Never install the machine in environments where it will be splashed with water or with high ambient humidity.

Delimitate danger areas and prevent public access to them when the machine is operating. Do not expose yourself to drainage areas or to vapour, condensation, fume or ventilation outlets. (TS10472-5 / 5.4.1)

Do not tamper unnecessarily with the machine's controls.

It should not be attempted to operate the machine if any of the following conditions are present:

- The side panels do not remain securely locked during the entire cycle.
- The machine is not connected to a proper grounded circuit.



The emergency system's ability to operate must be checked weekly.

Hands or objects should never be inserted into the roller until it has completely stopped and cooled. Doing so could result in serious injury.



Breach of or failure to observe the legislation and regulations covering health, safety and prevention of workplace risks applicable in the country where the machine has been installed, or actions contrary to common sense can cause personal injury or even death to the user.



Electric or mechanic modifications or manipulations are not accepted by the manufacturer. Foreign components should not be installed into the machine.

Any part of the machine that is replaced may affect its operation and the user's safety. For this reason, use only the manufacturer's original spare parts. Failure to comply with this warning can cause serious accidents, malfunctions and the loss of the machine's guarantee and certifications.

No part of the machine should be modified, repaired or replaced or servicing should not be attempted, unless specifically recommended in the user instructions or in published user repair instructions that the user understands and has the skills to carry out.

The machine should not be operated if it is suspected to be faulty, either visually, by noise or smell, or with missing or broken parts.



Carpeting, towel or waterproof fabrics should not be ironed in the machine.



The machine should be installed according to the installation instructions. All connections for gas, electrical power, and grounding must comply with local codes and be made by licensed personnel when required.

This machine must be used by personnel who are properly trained on how to use it.



Do not use this machine to handle laundry that has previously been sprayed, washed or impregnated with petrol, dry cleaning solvents or explosive or inflammable substances. These substances give off vapours that could ignite, explode or break down into toxic and/or highly explosive products.

All machines working at temperatures present a fire risk. Take extreme care: Clean the machine of inflammable materials such as lint, fluff, soot, etc. on a regular basis. Keep the environment free of combustible materials and place suitable extinguishers near the machine in easily accessible places.

The machine must not be run without a proper grounding (earth) connection.

The machine should always be disconnected from electrical supply before attempting any service.



The product should never be worked on with flammable materials and the product should not be cleaned with such materials.

The user must inquire the detergent product supplier about the risk of detergents and their combinations. The user is responsible to ensure that products are compatible and will not produce machine oxidation or damage either to people or to the washer. It should be noticed that the hypochloride (bleach), in certain conditions of use generates chlorine gas. Chlorine is a corrosive and oxidizing substance that, in high concentration and temperature, deteriorates the stainless steel and elastomers. There are other highly oxidizing agents, such as the ozone, that can have the same effect.



The dryer should not be used in the presence of dry cleaning fumes.



The fabric care instructions supplied by the textile manufacturer should always be followed.

The machine should be periodically cleaned. Cleaning will prevent the corrosion of the metallic parts, produce a higher output and provides a longer life for the machine. To clean the machine, water and chemical should be used, and it should be rinsed with a damp cloth and then be dried. The machine should not be cleaned with water jets or pressurized water.



Children should be supervised if they are in the vicinity of the equipment in operation.

Before removing a machine from service or disposing of it, consult the indications concerning dismantling. As a general rule, block all moving parts of the machine and prevent the risk of becoming trapped inside.



The inspections required by the regulations applicable to the country where the machine is being used must be carried out. You are also recommended to request an overall, detailed service of the machine by the Authorised Technical Service every year.



The energy must be completely turned off while servicing.



The machine should always be disconnected from electrical supply before attempting any service.

The electric supply, the gas supply, or the steam supply must be disconnected and locked out before removing any covers or guards from the machine to allow access for cleaning, adjusting, installation, or testing of any equipment.



Exhaust duct should be designed and installed by qualified professionals. Improperly sized ductwork will cause excessive back pressure. This results in inefficient working or even stopping of the dryer via vacuum flap (sail switch).

The duct size should not be reduced anywhere downstream of the ironer exhaust.

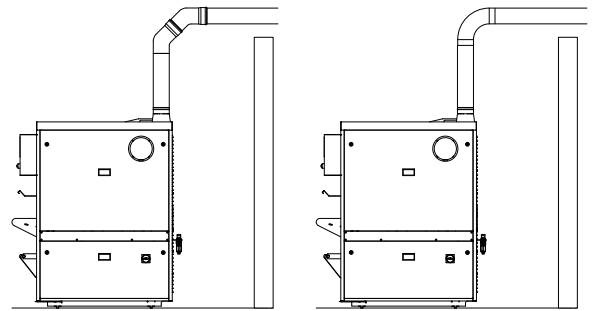

USE ELBOWS WITH MAXIMUM 45° ANGLES OR USE CURVED ELBOWS WITH 90° ANGLE

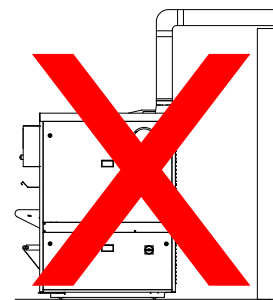

DO NOT USE NON-CURVED ELBOWS ANGLED AT 90°

Fig. 6 Exhaust Duct Elbow Angle Warnings

The usage of 90° angled elbows should be avoided. Instead elbows with 45° or 30° angles should be used.

The room air where the machine operates must be continually replenished from the outdoors.

Minimum 45 cm of clearance needs to be given overhead the ironer.

The ironer must never be operated without the lint filter or screen in place, even if an external lint collection system is used.

INFORMATION ON GAS

It is your responsibility to have ALL plumbing connections made by a qualified professional to ensure that the gas plumbing installation is adequate and conforms with local and state regulations or codes.



This flatwork ironer is set to use only the type of gas which is stated on the label next to the gas valve.

The flatwork ironer and its individual shutoff valves must be disconnected from the gas supply piping system during any pressure testing of the piping system. Failure to isolate or disconnect flatwork ironer from supply as noted can cause irreparable damage to gas valve, which will void the warranty.



Fire or explosion could result due to failure of isolating or disconnecting the gas supply as noted.

Never test for gas leaks with an open flame.



Any burner changes or conversion must be made by a qualified professional.

This gas heated flatwork ironer is not provided with an internal gas supply shut off valve. An external gas supply shut off valve must be provided.

Test all connections for leaks by brushing on a soapy water solution.

Gas supply must have an appropriate filtering.



Undersized gas piping will result in ignition problems, slow drying, increased use of energy, and can create safety hazards. (EN746-2 / 5.2.1.1) (TS10472-5 / 5.6)



The gas inlet temperature must be measured at installation, at commissioning and at any time when any kind of modification such as gas pressure or gas supply changes to the gas line has been made.



Minimum 15 mbar , maximum 60 mbar pressure is required for optimum operation.

The inlet gas connection must be ¾" in diameter.

WHAT TO DO IF GAS IS SMELLED? (ONLY FOR GAS HEATED MODELS)

DO NOT try to light any appliance.

DO NOT touch any electrical switch.

DO NOT use any phone in your building.

Clear the room, building or area of ALL occupants.

Immediately call your gas supplier from a neighboring phone. Follow the gas supplier's instructions.

If you cannot reach your gas supplier, call the fire department

SAFETY LABELS ON THE PRODUCT

Precautionary statements are found on machine decals. These precautions are intended for the personal safety of the operator, user, servicer, and those maintaining the machine.



Always follow the warnings instructed on the safety labels. Otherwise, danger resulting in personal injury, death, or property damage may arise.

Do not smear, cover, or peel off the safety labels.

If the safety labels are damaged or missing, purchase and affix new labels to their proper positions.



Inform our service center of the product name and safety label part number when placing a purchase order for safety labels.

The following list explains the types of the safety labels affixed on the machine.

Prohibited Signs

These signs communicate an action which has the potential to harm a person or damage a machine and therefore these actions shouldn't be executed. These signs are in a circular shape with a red border and diagonal strikethrough line and have a white background. See **Fig. 6** for Prohibited Sign pictograms.

Safety Critical Signs

These signs communicate an action which is safety critical, and/or important and therefore should be executed. These signs are in a circular shape with a blue background and white colored pictograms. See **Fig. 7** for Safety Critical Sign pictograms.

Hazard Signs

These signs communicate a zone which can become hazardous for a person and therefore should be paid attention to. These signs are in a triangular shape with a black border and a yellow background. See **Fig. 8** for Hazard Sign pictograms.



Fig. 7 Prohibited Signs

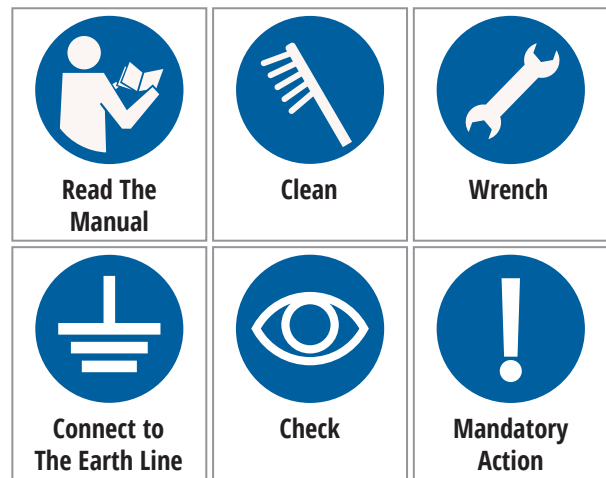

Fig. 8 Safety Critical Signs



Fig. 9 Hazard Signs

LABEL TEXT SECTIONS

Each safety label has one of the pictograms combined with a textual content. This textual content is formatted with a colored sign level indicator, the title of the label, an information sentence about the title and a detailed explanation about the label. The labels also include a serial number of the label for coding and renewal purposes.



Fig. 10 Label Text Sections

Sign Level Indicator

Indicates the level of the sign with one of the four different levels. These levels are "Danger", "Caution", "Warning", and "Important". Their meanings are explained below.

DANGER

Danger indicates the presence of a hazard that will cause severe personal injury, death, or substantial property damage if the danger is ignored.

CAUTION

Caution indicates the presence of a hazard that will or can cause minor personal injury or property damage if the caution is ignored.

WARNING

Warning indicates the presence of a hazard that can cause severe personal injury, death, or substantial property damage if the warning is ignored.

IMPORTANT

Important is used to inform the operator of specific procedures where minor machine damage will occur if the procedure is not followed.

Label Naming Scheme

Each label has a label number which is composed in the following style:

LFI.nnn.cc.rr

- The first letter is for "Label Flatwork Ironer"
- nnn is a specific 3 digit code for the label
- cc is the ISO3166-alpha2 country code
- "ml" means that the label does include texts in

"multiple" languages on it

- rr is the revision number of the label

Labels are organized to label kits for specific machine models. A kit includes all the required labels for a machine. Each label kit has a kit number which is composed in the following style:

K.MMMM.cc.rr

- The first letter is for "Kit"
- MMMM is the model identifier of the label kit
- cc is the ISO3166-alpha2 country code
- "ml" means that the label kit does include label texts in "multiple" languages on it
- rr is the revision number of the label kit

LOCATION OF THE LABELS ON THE 60xx MODELS

Labels are affixed onto designated locations on the machine to inform the operators and technicians on certain topics. These locations are indicated on Fig. 11 for the 60xx model ironers. In case of a label alteration the new labels must be affixed onto their correct locations.

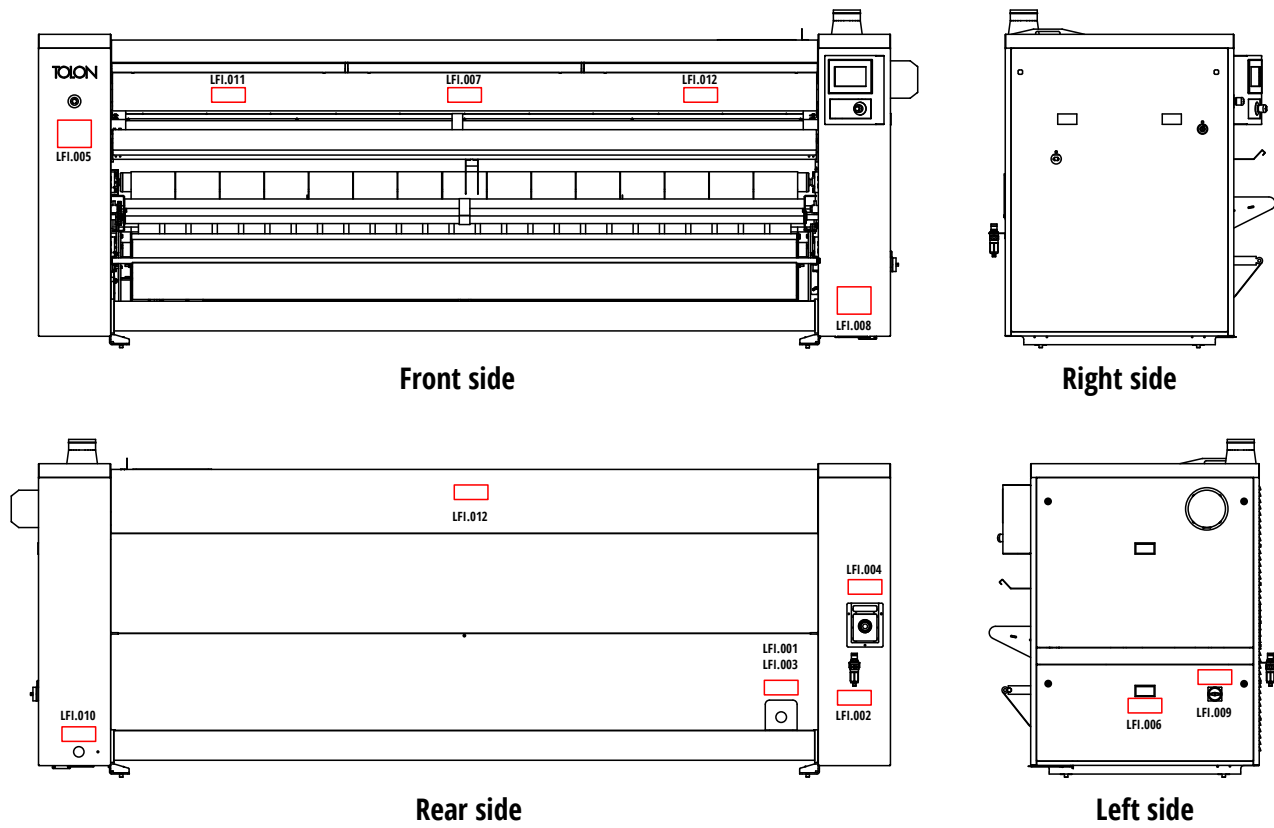

Fig. 11 TFI6026 and TFI6032 Label Locations

| Label No | Label |
|----------|--|
| LFI.001 | LPG 21 mbar |
| LFI.002 | Air 6 bar |
| LFI.003 | Natural Gas 21 mbar |
| LFI.004 | Clean The Filter |
| LFI.005 | Read the manual / All maintenance and repair must be done only by authorized personnel |
| LFI.006 | High Voltage |
| LFI.007 | Risk of injury ("Do not reach" warning) |
| LFI.008 | Clean The Filter |
| LFI.009 | Power Switch |
| LFI.010 | Earth Connection |
| LFI.011 | Risk of injury (Roller warning) |
| LFI.012 | Hot surface |
| L.044 | Oiling Point |

Table 8 Label Codes and Names for the TFI 60xx Models

LOCATION OF THE LABELS ON THE 35xx MODELS

Labels are affixed onto designated locations on the machine to inform the operators and technicians on certain topics. These locations are indicated on Fig. 12 for the 35xx model ironers. In case of a label alteration the new labels must be affixed onto their correct locations.

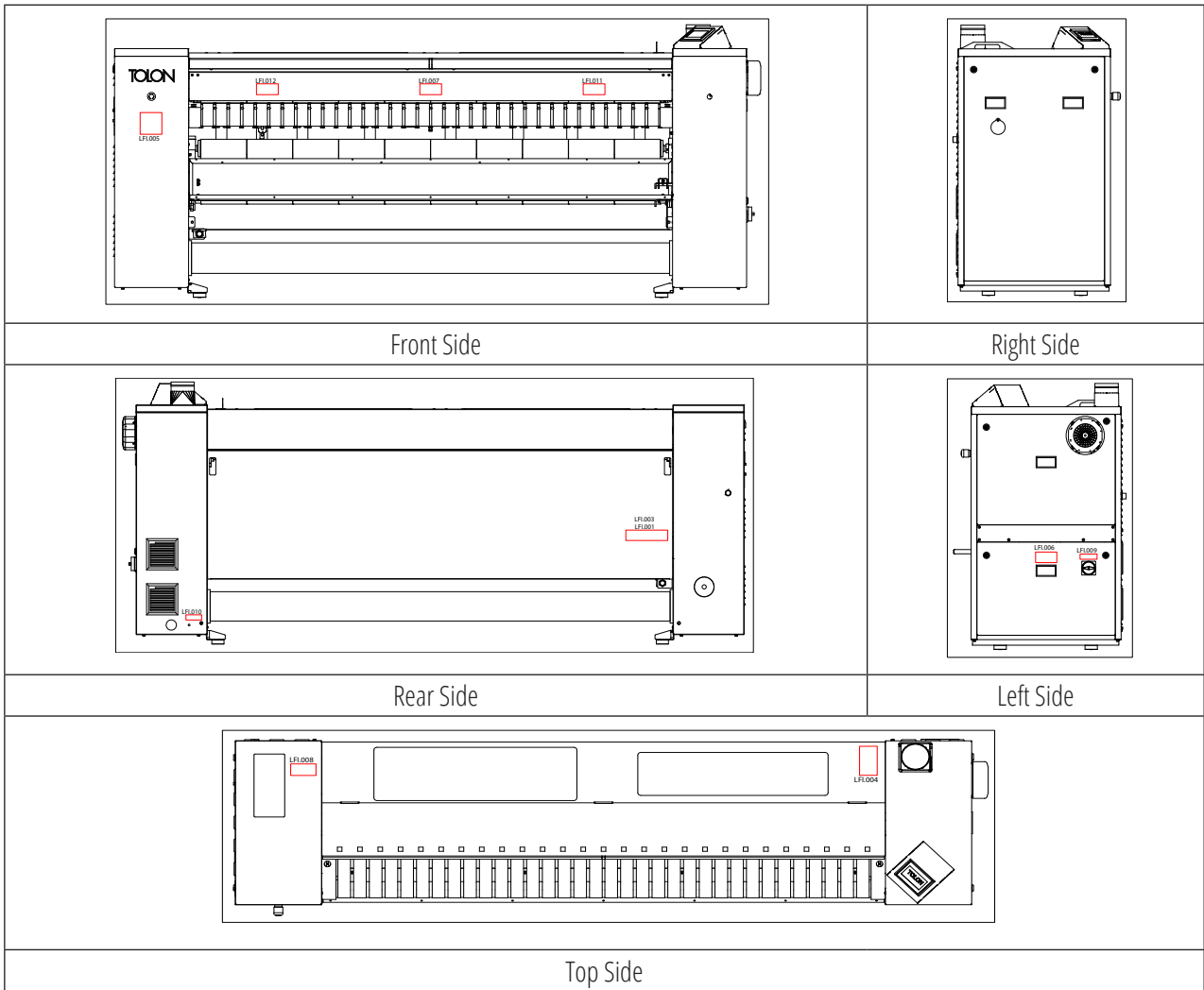

Fig. 12 TFI3516 and TFI3521 Label Locations

| Label No | Label |
|----------|--|
| LFI.001 | LPG 21 mbar |
| LFI.003 | Natural Gas 21 mbar |
| LFI.004 | Clean The Filter |
| LFI.005 | Read the manual / All maintenance and repair must be done only by authorized personnel |
| LFI.006 | High Voltage |
| LFI.007 | Risk of injury ("Do not reach" warning) |
| LFI.008 | Clean The Filter |
| LFI.009 | Power Switch |
| LFI.010 | Earth Connection |
| LFI.011 | Risk of injury (Roller warning) |
| LFI.012 | Hot surface |

Table 9 Label Codes and Names for the TFI 35xx Models

HANDLING AND TRANSPORTATION LABELS

There are labels on the packaging which inform the operators on handling and transportation details of the products.



| | |
|---|--|
|  <p>ISO 7000-0542</p> | <p>LIFT POINT Indicates the lifting point with a forklift (or from below).</p> |
|  | <p>WEIGHT Indicates the weight of an object that may be lifted or is being lifted.</p> |
|  | <p>CENTER OF GRAVITY Indicates the center of gravity of the transport package which will be handled as a single unit.</p> |
|  | <p>KEEP DRY Cargoes bearing this symbol must be protected from excessive humidity and must accordingly be stored under cover.</p> |

Table 10 Handling and Transportation Labels

IMPORTANT INSTRUCTIONS FOR USE AND PRESERVATION

INTENDED USE OF THE MACHINE AND INAPPROPRIATE USE

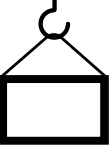
1. This machine is conceived and designed only for processing fabrics in a water bath or those that have previously been treated under these conditions. Any use other than this is contraindicated without written authorisation from the manufacturer.
2. Maximum machine operation, performance, reliability and durability are achieved with correct usage and maintenance and if an overall, detailed service is carried out annually by the Authorised Technical Service.
3. The components of the machine that are in direct contact with the chemical products involved in treating the laundry are detailed in the manual.
4. The user must consult the supplier of the chemical products used throughout the whole linen treatment process regarding the risks associated with their products and their combination. It must be ensured that the products ARE COMPATIBLE and that they will not cause oxidation or deterioration of the machine or any injury to the people using them.

It should be noted that, under certain usage conditions, hypochlorite (bleach) generates chlorine gas.

Chlorine is a corrosive, oxidising substance which, at high concentrations and temperatures, damages stainless steel and elastomers.

This same effect can also be caused by other strongly oxidising agents, including ozone.

5. Follow the treatment recommendations for each fabric indicated by its manufacturer. The manufacturer of the machine accepts no responsibility for damage caused by inappropriate treatment of a fabric.
6. Periodically clean the outside of the machine to prevent damage to its metal parts. This will improve safety and extend its life. Use water and detergent to clean the machine. Rinse with a damp cloth and dry. Use a suitable vacuum cleaner to remove accumulated lint. Water jet or pressurised steam cleaning is prohibited.
7. Never use aggressive products to clean the machine or the premises. There are products on the market that give off highly corrosive vapours.
8. If machine is left idle for long periods of time, it must be protected from humidity and temperature variations.
9. Faults arising from improper machine operation may void the warranty.
10. When asking for information on your machine, mention the model and the serial number. This information can be found on the serial plate incorporated into the machine.
11. The manufacturer provides all necessary technical information and the documents required for its use with every machine. Keep it in good condition.

EXPECTED MACHINE USE and DON'TS



APPROPRIATE USE

This machine has been conceived and designed for the industrial ironing and drying of flat laundry items washed in water free from inflammable or volatile products.

Any other use different to that described, without written authorization from the manufacturer, will be taken as inappropriate to the terms of use.

INADVISABLE USE

Never operate the machine without all the covers and protection devices being correctly placed and fastened. The following points must be taken into account to avoid deterioration of the ironer:

- Do not iron linen previously treated or washed with petrol, dry cleaning solvents, and other flammable or explosive substances. These substances give off vapours that could ignite or explode.
- Do not iron articles of linen whose composition impedes water retention.
- Do not insert linen with hard components which can damage the surface of the cylinder or the fabric of the ironing straps, such as buttons, zippers, metal components, tissues containing rubber etc. into the ironer.
- Do not iron fabric or fibres at temperatures above those recommended by the manufacturer of the material.
- Do not put linen which contain components unable to withstand ironing temperatures into the ironer.
- While ironing, avoid mixing articles of different thicknesses and humidities, since this will slow down the ironing to the detriment of fine materials.
- Do not use reverse rotation for any use other than to free a trapped person or object.
- Never iron without alternately covering the ironing area (Right/Left). Follow the screen to cover the hottest area of the cylinder at all times. (TS10472-5 / 5.4.2)
- Do not switch off the power with the machine at a temperature above 70°C except in case of emergency.
- In the case of small items, do not leave excessive space free across the width of the cylinder.
- Do not put the machine on minimum speed during the cylinder's warming and cooling cycles.
- Do not halt the machine if the ironing straps are not completely dry, except in case of emergency.
- Avoid ironing during the cooling cycle to prevent the ironing straps from remaining damp and causing rusting in the cylinder.

- Do not iron at temperatures below 110°C, since this could lead to rusting in the cylinder.
- Do not attempt to fold items without covering the photocell.
- Do not fold more than one article at a time except on a machine fitted with the optional double photocell, in which case two items can be fed in at a time provided that they are of equal length.

PROTECTION, SAFETY AND CONTROL ELEMENTS



Never override a protection, safety or control devices. Never operate the machine without all the safety guards correctly in place and fixed.

Safety Guards

To safeguard the operator, a set of guards screen the machine from its surroundings. (TS10472-5 / 5.2.2.2) (TS10472-5 / 5.2.2.3)

Switch Breaker

To connect or disconnect the machine from the external power supply. (TS10472-5 / 5.4.4)

Emergency Stop Button

The emergency stop button is a safety device. The machine is equipped with 2 emergency stop buttons, which is identified with a red button on a yellow background and which are located on the right-hand and left-hand front cover. The function of this element is to stop the machine immediately and keep it halted.

Hand Protection Guard (Movable Guard with Locking Device)

The hand protection guard is a SAFETY element consisting of a tilting cover located on the machine's feeding tray designed to prevent hands from being inserted into the cylinder and the trapping point between it and the pressure roller. Pushing or pulling the movable cover HALTS the cylinder immediately. The machine will remain in this state until the cover is moved back to the resting position. The hand guard stop is also assigned to operate as a safety stop from any part of the introduction zone. Checking the proper functioning of the hand guard is an essential prerequisite for starting up the ironer. (TS10472-5 / 5.2.1.1) (TS10472-5 / 5.2.1.2)

Temperature Probes

These probes constantly monitor the temperature of the surface of the ironing cylinder, adapting it to the programmed value.

Electric Circuit Safety Measures

To protect the electric circuit against external malfunctions and prevent any malfunctioning causing damage to the operator. The principal ones are: Automatic switches, circuit separation transformer, protection for the motors, external protection (EP). Protection fuses of the control circuit.

Pressure Switch of Maximum Pressure

Controls the suction in the exhaust circuit.

Minimum operating pressure: 0.8 mbar

In case of a drop in suction in the exhaust circuit, the pressure value decreases, and the pressure switch stops the machine from running and also emits an alarm.

Safety Thermostat

This thermostat limits the surface temperature of the cylinder. It protects against an overheating of the cylinder caused by a fault in the system regulating the ironing temperature. It's set to 110°C (230°F).

Safety when Starting the Flatwork Ironer

If a momentary interruption of the power supply occurs, the machine shuts down at once and does not resume until the corresponding start button is pressed.

Heating System Start-up Safety Feature

A power cut or the detection of an alarm automatically switches off the heating system, and it does not resume until the corresponding buttons are pressed.

Flame Control

Burner flame safety detection.

Ignition Delay

With each ignition order, there is a delay of 15 seconds before the gas safety valve opens. During this time any gases that may remain inside the cylinder are flushed out.

If the gas burner fails to ignite, or there is an alarm, there is an ignition delay of 90 seconds. This time period is stored in the ironer control memory, and the delay will be implemented in full even if the machine is disconnected from the power supply.

RECEPTION AND STORAGE

RECEIPT

The nameplate (Serial Plate) is located on the rear of the machine.

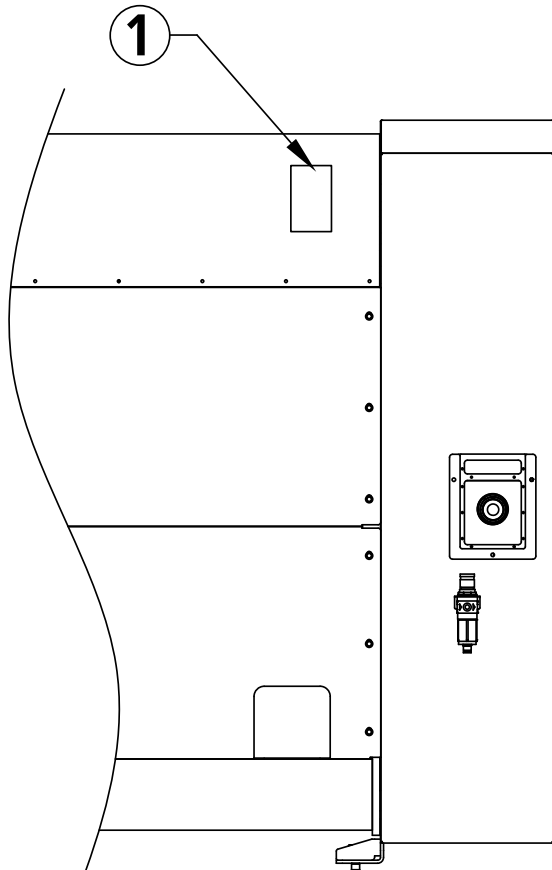

Fig. 13 Location of the Serial Plate

Upon delivery inspect the ironer for the below points:

- Check that the product has not suffered any damage during transit. (Any damage caused in this way will not be attributable to the manufacturer, and the appropriate claim should be made against the party responsible for transporting the product.)
- The data on the specification nameplate of the delivered machine complies with the requirements stipulated in the order: Model, voltage, frequency and type of heating.

STORAGE

To store the machine, keep in mind the following points:

- Do not stack the machines.
- Never store the machine where it will be exposed to the weather.
- Store the machine in a moisture free location (oxidation could appear on the cylinder).
- Apply anti-corrosion protection if they are stored and exposed to maritime humidity.

HANDLING AND TRANSPORTATION



Faults and damages arising from failing to comply to the warnings and instructions in the operating manual and on the machine, not minding the signs, or ignoring the warnings of the authorized service will leave the product with irreversible damage and OUT OF THE SCOPE OF WARRANTY.

It is recommended to transport the machine with a specialist company and personnel.



There is a danger of the machine to fall down or topple on to people while carrying.

The machinery should be lifted with appropriate workforce and equipment according to the weight stated on its package. The capacity and balance settings of the carrier and loader vehicles should be considered.

The handling operations and transporting the product to the working place must be monitored by an authorized service.

The machine should not be carried on inclined or rough surfaces.

Always transport the machine in upright position.

MOVING WITH A CRANE



The Flatwork Ironer models can't be lifted with a crane. These machines must only be transported via a forklift or a pallet truck.

MOVING WITH A FORKLIFT

The machine should be lifted and carried from the marked lifting points. 

Approach and lift from behind the machine.

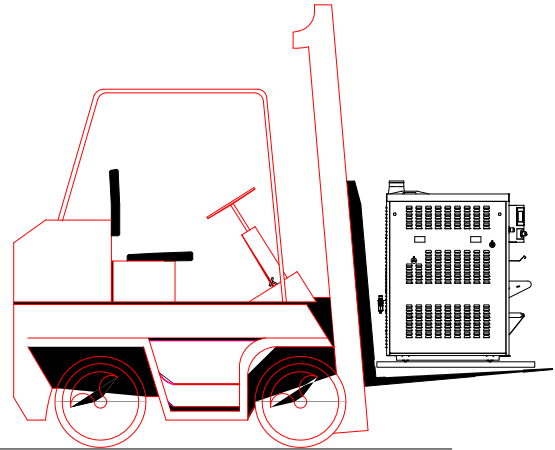

Fig. 14 Forklift Lift Points

Consider the center of gravity when lifting.

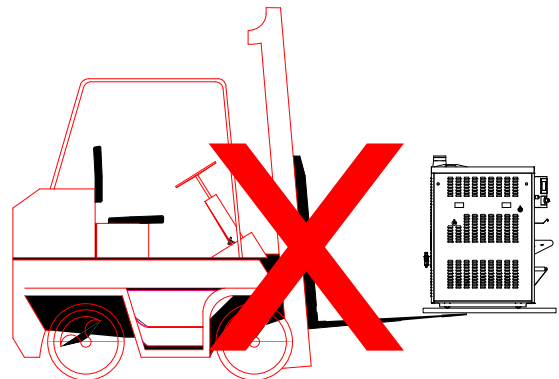

Fig. 15 Forklift Center of Gravity Warning

Do not lift from the sides.

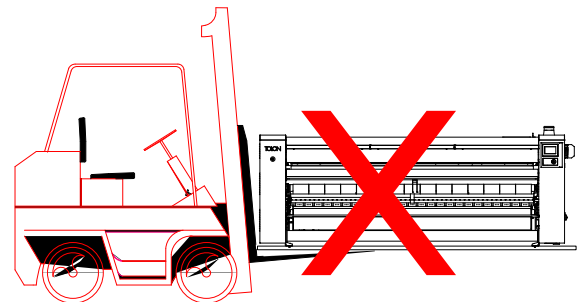

Fig. 16 Forklift Side Lifting Warning

MOVING WITH A PALLET TRUCK

The machine should be lifted and carried from the sides by using two (2) pallet trucks, one for each side.

The feet of the machine must seat on the pallet truck rods.

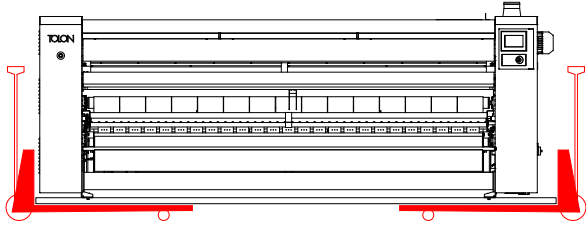

Fig. 17 Pallet Truck Lifting Points

INSTALLATION AND START UP

INSTALLATION, POSITIONING AND LOCATION WARNINGS



The manufacturer is obliged to advise you that failure to install this machine properly may produce a fault or cause poor machine operation resulting in serious bodily injury.

The manufacturer declines all responsibility in these cases. The specifications nameplate is located on the right-hand side of the rear area (back view of the machine).

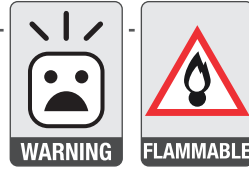

SPECIFIC WARNING FOR MACHINES INSTALLED ON USA/CANADA PREMISES.

To reduce the risk of fire, this machine must be installed on a concrete floor without any covering.



The ironer must be installed on a flat floor surface, perfectly even and capable of supporting the weight of the machine.

Any inflammable substances covering the floor such as rugs and carpets must be removed.

A fire extinguisher must be placed inside the premises, in a place easily visible and easily accessible. Type of fire extinguisher and location must be in accordance with the regulations of the country in which the ironer is installed. (TS10472-5 / 5.4.4)



SPECIFIC WARNING FOR IRONERS WITH GAS HEATING

Before carrying out the installation of the machine, check the local gas supplies (type of gas and pressure) are compatible with the equipment requirements.

This appliance must be installed in accordance with the rules in force, and must be used only in areas that are adequately ventilated.

GENERAL INSTALLATION AND LOCATION INFORMATION

The location and installation instructions set out in the corresponding sections must be complied with to ensure that the ironer functions properly and safely. These are in particular:

- Hazard warnings.
- Indications relating to the location of the machine.
- Indications relating to the areas of use indicated in the corresponding plans.
- Size and connection of the ducts for the gas heating supply.
- Size and connection of the electricity supply conduits.
- Size and connection of the exhaust duct.

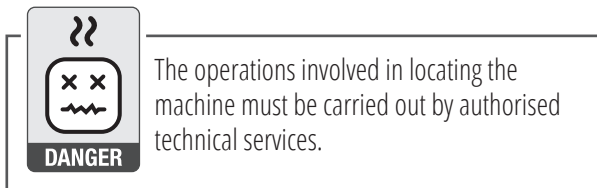

The machine must be installed on a flat floor surface, perfectly even and capable of supporting the weight of the machine. A concrete floor with a resistance equal to or greater than 250kg/cm² (4,000 psi) is recommended.

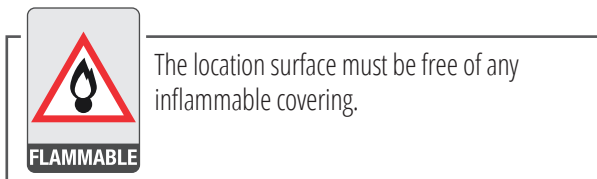

Take into account the minimum amount of clearance required for operation. The operation clearances facilitate good working conditions and machine servicing and maintenance spacing. Refer to the clearance zones and values in **Fig. 16** and **Fig. 17**.

If the ironers are installed on metal surfaces the aforementioned surfaces must be grounded by an electric wire independent to the ground ironer connection.

ENVIRONMENTAL CONDITIONS

The following work environmental conditions must never be exceeded at the installation site regardless of the day or time of year to achieve ideal running and operating conditions for the machine:

| | | |
|-------------------|------------|--------------------------|
| Temperature | Min. °C | 5 |
| | Min. °F | 41 |
| | Max. °C | 40 |
| | Max. °F | 104 |
| Relative Humidity | Max. | 80% without condensation |
| Altitude | Max. meter | 3000 |
| | Max. feet | 10000 |
| Vibrations | free | |
| Lighting Level | Min. lux | 300 |

Table 11 Environmental Conditions

INSTALLATION OF THE PRODUCT



Because the laundry environments are corrosive, the selected area for the installation must be easy to ventilate, must have proper energy resources and adequate space for the service to work.



The blueprint references and recommendations given by the manufacturer are essential during product installations. In case of project work absence it's recommended that space for approaching, maintenance, repair and service around the product is reserved as shown in **Fig. 18** and **Fig. 19**.

When positioning the machine, pay careful attention to:

- The minimum clearances (distances) between the machine and walls or combustible materials.
- The minimum amount of space set aside for its use.
- The minimum amount of space set aside for its maintenance.

INSTALLATION CLEARANCES

Installation Clearances for standard TFI3516, TFI3521, TFI6026 and TFI6032 models

Top View

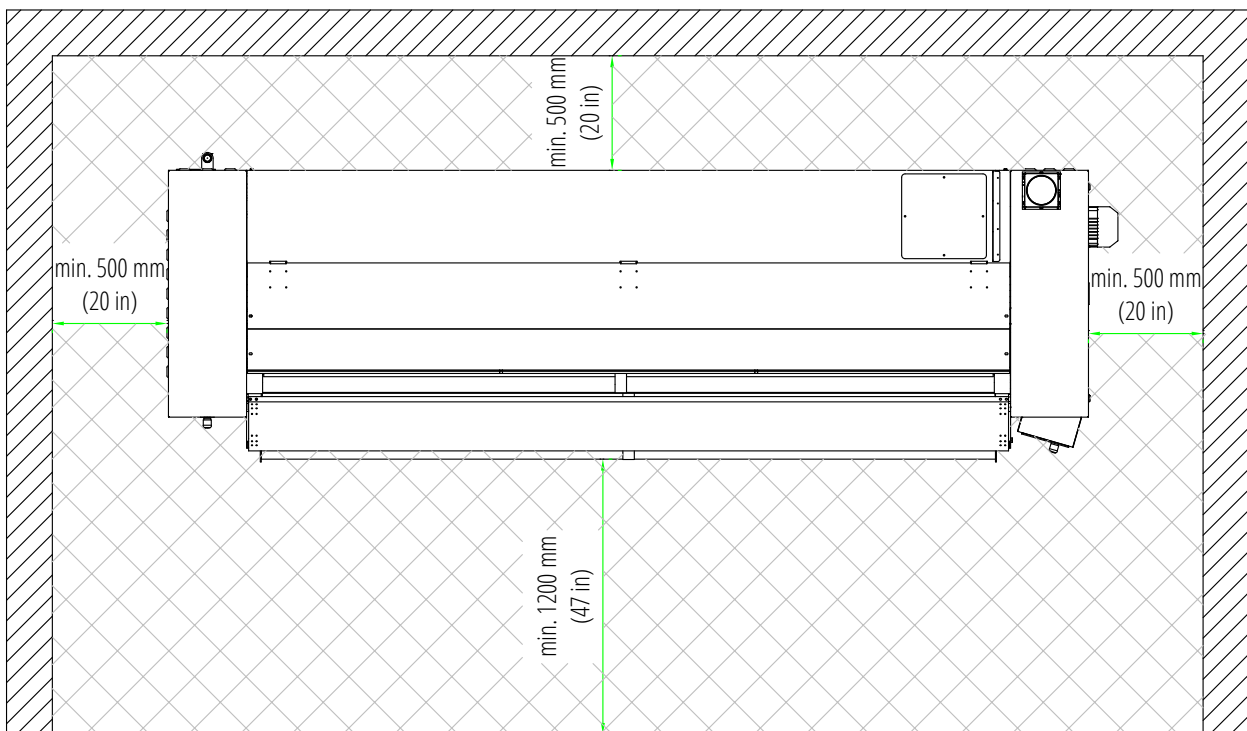

Fig. 18 Top Views for Installation Clearances on standard TFI3516, TFI3521, TFI6026 and TFI6032 models



The measurements in **Fig. 18** "Top Views for Installation Clearances on standard TFI3516, TFI3521, TFI6026 and TFI6032 models" do define the clearances required for the operation and basic servicing&maintenance of the ironer.

The length of some components, such as the electrical heating elements or the gas burner is almost equal to the total width of the machine. The operations for dismantling or replacing these components will require larger surface areas.

Installation Clearances for rear exit TFI6026 and TFI6032 models

Top View

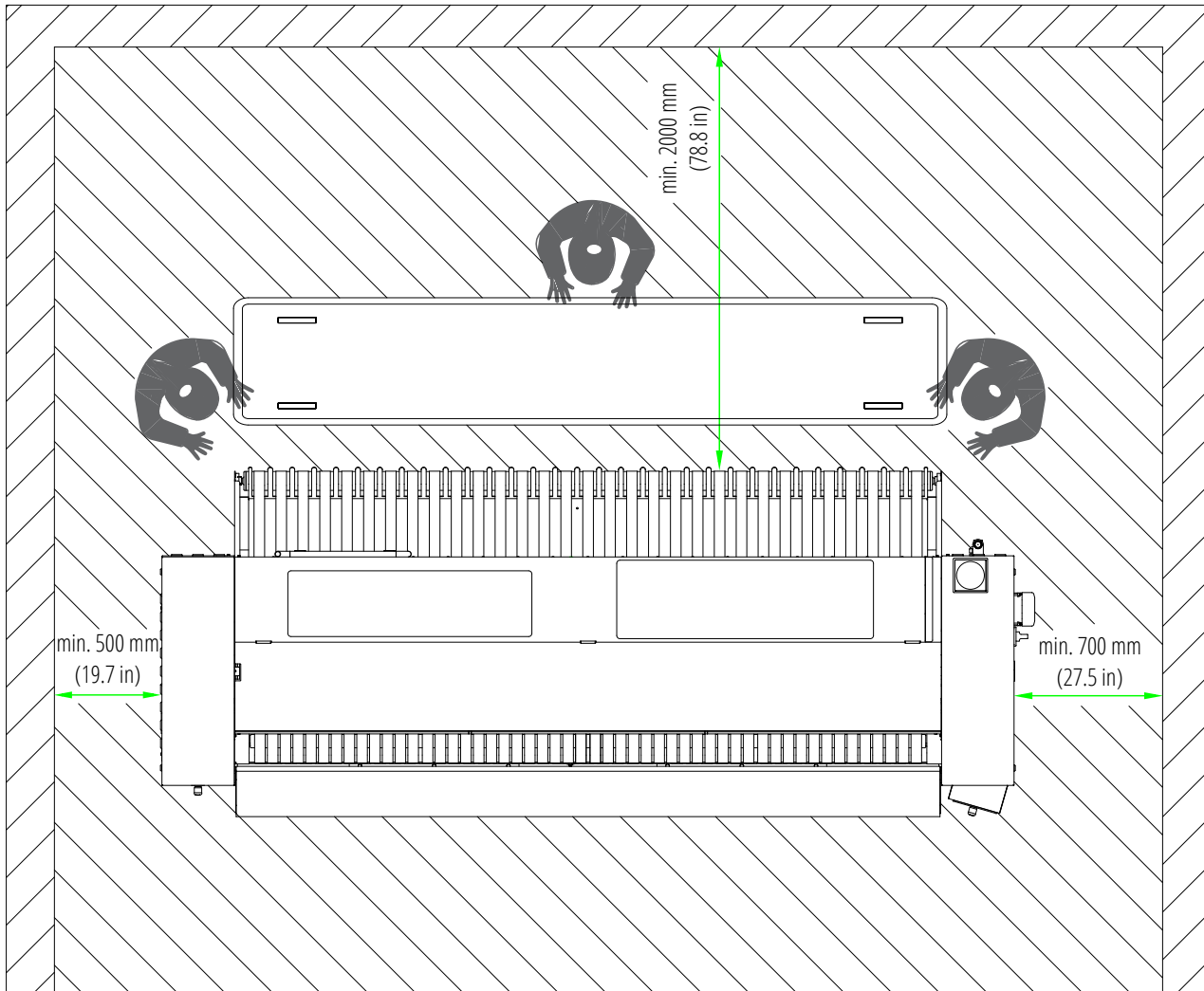

Fig. 19 Top Views for Installation Clearances on rear exit TFI6026 and TFI6032 models



CAUTION

The measurements in **Fig. 19** "Top Views for Installation Clearances on rear exit TFI6026 and TFI6032 models" do define the clearances required for the operation and basic servicing&maintenance of the ironer.

The length of some components, such as the electrical heating elements or the gas burner is almost equal to the total width of the machine. The operations for dismantling or replacing these components will require larger surface areas.

LOCATION REQUIREMENTS



The ironer must be installed on noncombustible and nonflammable floors only.

Provisions for adequate air supply must be provided as noted in this manual (refer to "Room Ventilation Conditions" in p.37).

Clearance provisions must be made from noncombustible construction as noted in this manual (refer to "Location Requirements" in p.36).

Provisions must be made for adequate clearances for servicing and for operation as noted in this manual (refer to "Installation Clearances" in p.34).

The ironer must be installed with a proper exhaust duct connection to the outside as noted in this manual (refer to "Exhaust Requirements" in p.40).

The ironer must be located in an area where correct exhaust venting can be achieved as noted in this manual (refer to "Exhaust Requirements" in p.40). The ironer should be located where a minimum amount of exhaust duct will be necessary.

The ironer must be installed with adequate clearance for air openings into the combustion chamber.



The ironer produces combustible lint and must be exhausted to the outdoors. Every 6 months, inspect the exhaust ducting and remove any lint buildup.



The ironer must be installed in a location/environment, where the ambient temperature remains between 4 °C (39.2 °F) and 50 °C (122 °F).



It is mandatory that the floor which the product will sit on is flat and the product is well levelled and balanced. Wrong or unbalanced installation will cause harm both to the product and to the floor, and the operation of the product will be noisy and annoying.



The ironer must not be installed or stored in an area where it will be exposed to water or weather.

The installation of the products which have a "ground anchoring label" must be done according to its project.

The balance of the product must be levelled by using its adjustable feet before operation.

ROOM VENTILATION CONDITIONS



The ventilation on the premises must comply with the regulations currently in force in the country in which the machine is to be installed and must be approved by a competent technician.

In countries where there are no regulations governing the ventilation of premises with gas heating, the ventilation conditions set forth in the section "**Ventilation Openings for Gas Heated Models**" on p.38 are recommended.

This ironer must not be installed in premises without adequate ventilation.

Inadequately ventilated premises can seriously affect the people's health.

Always keep the ventilation system clear.

Never place objects in places where they can obstruct the ventilation openings on the premises.

In the case of there being various forced exhaust and/or convection equipment or boilers on the same premises, the complete section of the opening to the outside must amount to at least the sum of the ventilation sections for each piece of equipment.

To avoid the presence of crossed air currents never install equipment with convection ventilation between forced exhaust equipment and the ventilation openings.



DRY CLEANING MACHINES

The installation of dry cleaning machines and ironers with gas heating in the same premises is incompatible.

Some dry cleaning machines in poor condition may emit gases from solvents into the local atmosphere, and these, on interacting with temperature, may become highly toxic and corrosive gases. Extreme care must be taken in the maintenance of these machines.

Ventilation Openings for Electric Heated Models

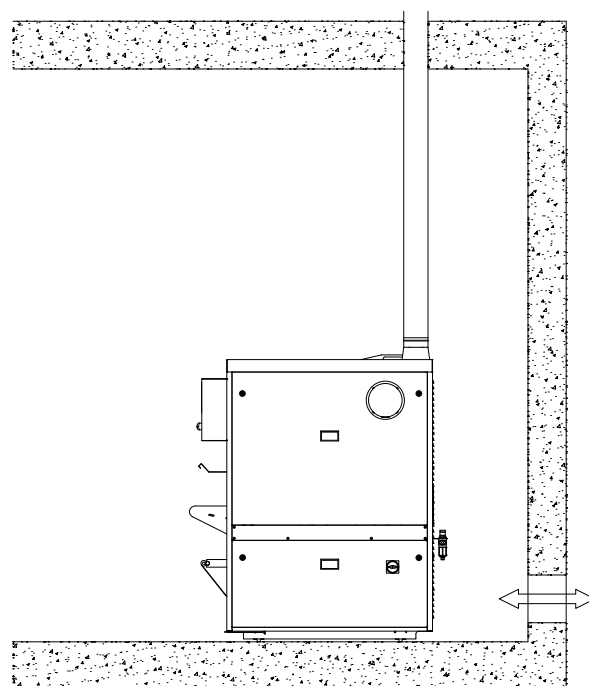

Fig. 20 Ventilation Openings for Electric Heated Models

The premises must be sufficiently ventilated to replace the air used by vapour extraction. (**Fig. 20**).

Refer to vapour extraction flow values (for electric heated models) specified in the technical and connection datasheets for the machine.

As a piece of guiding information, the premises should be ventilated with openings of 1,300 cm² (1.4 ft²).

In openings protected with a deflector grille, the opening should be 1,800 cm² (1.94 ft²).

In the case of rectangular air openings, the longest side must not be more than double the length of the smaller side. This opening must be located close to the ironer and near the floor.

The ventilation air openings must not come into contact with the possible air cavities in the walls.

Ventilation Openings for Gas Heated Models

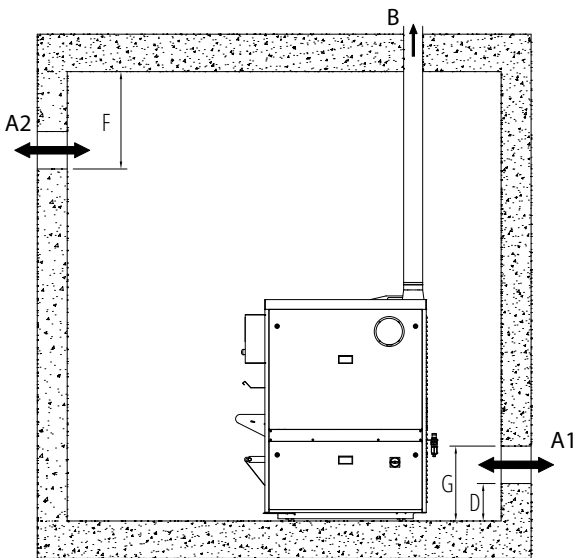

Fig. 21 Ventilation Openings for Gas Heated Models

The air must be supplied through openings in the walls of the premises which are in direct contact with the outside air.

These openings must be protected to prevent entry of water or foreign bodies.

Refer to vapour extraction flow values (for gas heated models) specified in the technical and connection datasheets for the machine.

Two openings communicating with the outside are recommended: one located at the top of the premises (A2) and another at the bottom (A1), in close proximity to the machine. It is advisable to create these openings on opposite walls.

In the case of rectangular air openings, the longest side must not be more than double the length of the smaller side.

The machine's exhaust duct (B) should always lead directly to a secure outside location and never be connected to any other duct or flue.

Size of the A1 and A2 openings

- The minimum free surface area of the openings (S_i) should be 5 cm^2 (0.775 in^2) per kW of nominal heat consumption (referred to as H_s) installed.
- The minimum area of each of the openings should never be less than 250 cm^2 (38.75 in^2).
- In openings protected with protective grilles, the free surface of the opening must be equal to or greater than the minimum area indicated.

Position of the A1 and A2 openings

Bottom Opening (A1)

- The bottom edge should be at a height (D) of less than or equal to 15 cm (5.9 in) from the floor of the premises.
- The top edge should be at a height (G) of less than or equal to 50 cm (20 in) from the floor of the premises.

Top Opening (A2)

- The bottom of the opening should be at a maximum distance (F) of 30 cm (11.8 in) from the ceiling.

LEVELING OF THE MACHINE

It is mandatory that the floor which the product will sit on is flat and that the product is well levelled and balanced. Wrong or unbalanced installation will cause harm both to the product and to the floor, and the operation of the product will be noisy and annoying.

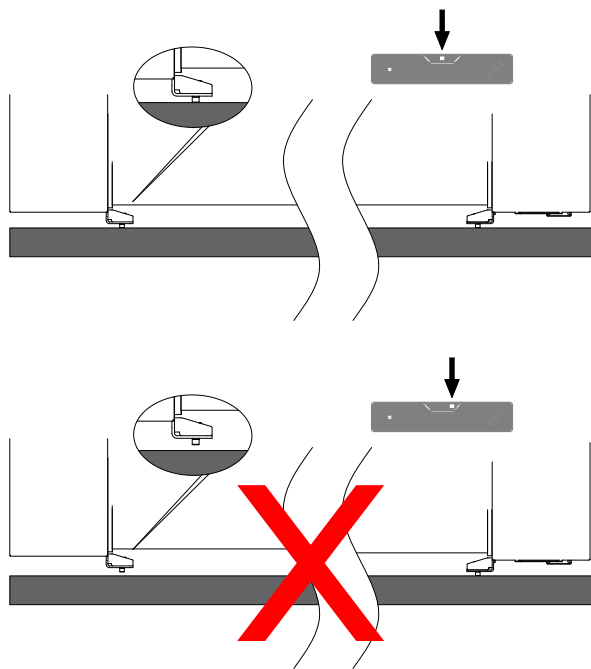
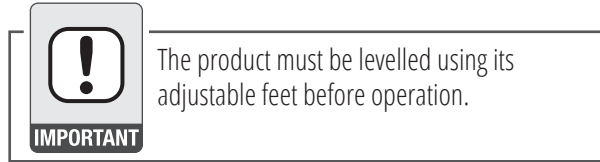

Fig. 22 Correct and False Feet Adjustment for Product Leveling

FEET ADJUSTMENT

Rotate the feet of the machine clockwise or counterclockwise by using the feet adjustment nuts to level it.

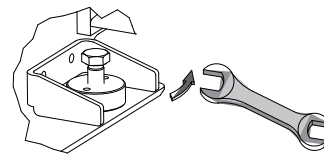
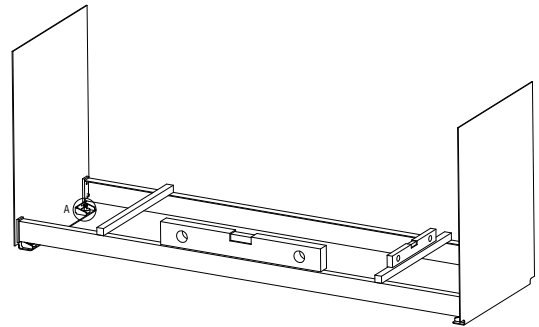

Fig. 23 Feet Adjustment for the Flatwork Ironer Models

EXHAUST REQUIREMENTS



It is compulsory for exhaust ducts to be installed by an authorised installer company, and such installations must conform to the existing laws in the country or area where the machine is used.

The design of the flue system shall be such that any condensate formed when operating the appliance from cold shall either be retained and subsequently re-evaporated or discharged. (EN746-2 / 5.2.1.1) (TS10472-1 / 5.5.2) (TS10472-5 / 5.6)



The soot and fluff must be periodically cleaned from the inside of the exhaust ducting from the machine to outside. Do not forget that both fluff and soot are highly combustible materials. We recommend carrying out this operation at least every three months.

A faulty extract system can be the cause of grave risks to the health of operators.



Specific warning for machines with gas heating.

The exhaust duct may extract unburnt gas. Some components from dry cleaning processes may decompose into toxic and/or corrosive products if they pass through burner flames.

For this reason, the machine's exhaust duct should always lead directly to a secure outside location and never be connected to any other duct or chimney.

Specifications for the ducting

See the "Connection Details" table (Table 10) for the corresponding model for flow, diameter and position of connection data.

The ducting should be as short as possible, and the section specified in Details of Extraction Ducts must be maintained throughout the whole ducting. A lengthier ducting will require a bigger section.

Ducting pipes must be fire-resistant, rigid, anti-corrosive with

a smooth inside surface and these properties must remain unaltered at a minimum temperature of 150°C (302°F). (EN746-2 / 5.2.1.1 / 5.2.1.5) (TS10472-1 / 5.5.2) (TS10472-5 / 5.6)

Ducting pipes must be watertight all around and thermally insulated up to a height of at least 2.7 metres (107 in) from the floor.

If the extraction process causes a significant noise, it is advisable to fit soundproofing to the ducting pipes.

Ducting pipes must have the minimum number of bends. To avoid losing contents, the angle of the bends must not be more than 45°.

Ducting pipes must always be conducted in an upwards direction (An upwards gradient of at least 3% and the shortest length possible).

The ducting outlet must be clear and separate (must never be joined to any other duct).

The diameter of the cavity has to be 100 mm (4 in) greater than the ducting when passing through walls or roofs made of wood or other combustible materials. In these cases the ducting must be protected by fire resistant material.

Two measuring points should be envisaged that can be closed during normal operation (**Photo 1**):

| A. Opening for inserting the flue gas analyser probe | |
|--|-------------------|
| Approximate diameter | 10/12 mm (0,5 in) |
| Height (H2) from the first run of ducting | 1 m (40 in) |
| B. Pressure control opening | |
| Approximate diameter | 3.5 mm (0.14in) |
| Height (H1) from the first run of ducting | 0.5 m (20 in) |

Table 12 Ducting Measuring Points

When ducting above 10 m (400 in) or if there is a lot of water from condensation, install a 1/2" or a 3/4" drain at the lowest point, to drain the water. In cold temperatures, insulate the ducting to reduce condensation.

The outlet for the exhaust ducting must be higher than the highest point on the building itself or nearby buildings.

The entire unconnected distribution system must be blocked, closed or blind flanged by means of metallic parts. (EN746-2 / 5.2.1.3) (TS10472-1 / 5.5.2) (TS10472-5 / 5.6)

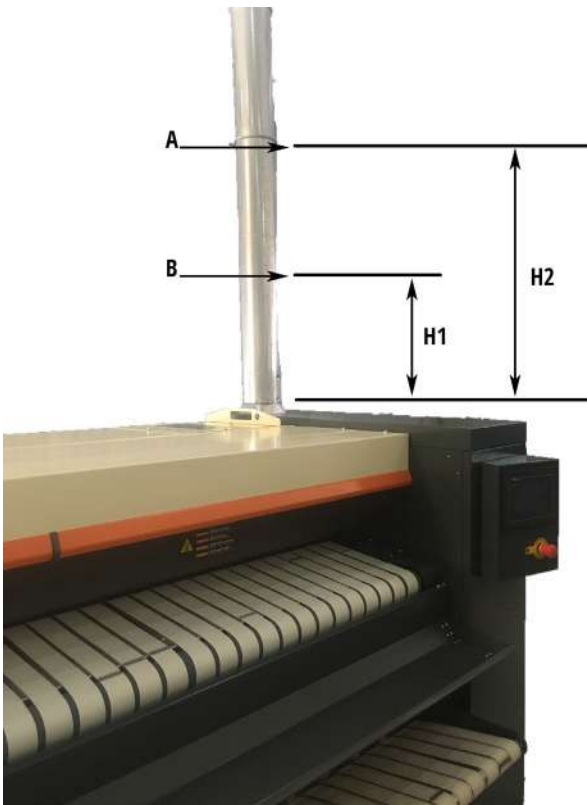

Photo 1 Ducting Measuring Points

Assembling the exhaust ducting

Once the ironer is situated in its final position and levelled, secure the exhaust duct to the outlet on the ironer.



To prevent accidental contact with the ironer fan through the extraction output, the extraction pipe joint must be fitted using a device that is secure and requires a tool for its disconnection.

| | Unit | TFI6026 | TFI6032 |
|-------------------------------|-------------------|---------|---------|
| Gas Heated Models | | | |
| Minimum Flow | m ³ /h | 695 | 695 |
| | cu.yd/h | 909 | 909 |
| Diameter | mm | 130 | 130 |
| | in. | 5,12 | 5,12 |
| Electric Heated Models | | | |
| Minimum Flow | m ³ /h | 695 | 695 |
| | cu.yd/h | 909 | 909 |
| Diameter | mm | 130 | 130 |
| | in. | 5,12 | 5,12 |

Table 13 Exhaust Ducting Technical Datasheet for TFI60xx series

| | Unit | TFI3516 | TFI3521 |
|-------------------------------|-------------------|---------|---------|
| Gas Heated Models | | | |
| Minimum Flow | m ³ /h | 450 | 450 |
| | cu.yd/h | 589 | 589 |
| Diameter | mm | 110 | 110 |
| | in. | 4,33 | 4,33 |
| Electric Heated Models | | | |
| Minimum Flow | m ³ /h | 450 | 450 |
| | cu.yd/h | 589 | 589 |
| Diameter | mm | 110 | 110 |
| | in. | 4,33 | 4,33 |

Table 14 Exhaust Ducting Technical Datasheet for TFI35xx series

ELECTRICAL CONNECTIONS



The power must be completely cut off during installation and servicing.

It is necessary to equip the electrical installation with proper cables and fuse systems. Refer to tables 15 to 20. The values in these tables are calculated based on copper wiring and overhead cables. It is not recommended to use aluminium cables. The values change in case of conduit or buried cable usage.

The cross section of the cables must be determined by qualified experts by calculating the power and the capacity of the machine, and the distance of the cables to the energy source.

It's recommended to use cable terminals to connect the grounding cable to the grounding connection. The grounding connection is marked with the "Earth Connection" sticker. Its placement is shown on the "Exterior Components and Dimensions Diagrams" in p.11 and p.13.



Fig. 24 Earth Connection Sticker







For the sake of work and personnel safety the product must be connected to a grounding line.



For personal safety, the machine must be electrically grounded in accordance with local codes.

Separate electrical boxes should be installed for each laundry division (eg. washer extractors, dryers, ironers) and in those boxes, separate fuses and circuit breakers should be installed for each individual machine (for maintenance and service purposes).

CABLE AND FUSE VALUES OF THE 60XX SERIES

| 60XX SERIES CABLE AND FUSE VALUES FOR 240V THREE-PHASE VOLTAGE | | | |
|--|-----------------------|---------|---------|
| | Unit | TFI6026 | TFI6032 |
| Gas Models | | | |
| Circuit Breaker | ampere | 3 x 10 | 3 x 10 |
| Cable Quantity and Section Area | qty x mm ² | 4 x 4 | 4 x 4 |
| | qty x AWG | 4 x 12 | 4 x 12 |
| Cable Length | meter | 18 | 14 |
| | feet | 59 | 45.9 |

Table 15 Cable and Fuse Values for 240V Three-Phase Voltage

| 60XX SERIES CABLE AND FUSE VALUES FOR 380V THREE-PHASE VOLTAGE | | | |
|--|-----------------------|---------|---------|
| | Unit | TFI6026 | TFI6032 |
| Electric Models | | | |
| Circuit Breaker | ampere | n/a | 3 x 125 |
| Cable Quantity and Section Area | qty x mm ² | 4 x 2.5 | 4 x 25 |
| | qty x AWG | 4 x 4 | 4 x 4 |
| Cable Length | meter | n/a | n/a |
| | feet | | |
| Gas Models | | | |
| Circuit Breaker | ampere | 3 x 10 | 3 x 10 |
| Cable Quantity and Section Area | qty x mm ² | 4 x 2.5 | 4 x 2.5 |
| | qty x AWG | 4 x 14 | 4 x 14 |
| Cable Length | meter | 30 | 30 |
| | feet | 98.4 | 98.4 |

Table 16 Cable and Fuse Values for 380V Three-Phase Voltage

| 60XX SERIES CABLE AND FUSE VALUES FOR 480V THREE-PHASE VOLTAGE | | | |
|--|-----------------------|---------|---------|
| | Unit | TFI6026 | TFI6032 |
| Electric Models | | | |
| Circuit Breaker | ampere | n/a | 3 x 125 |
| Cable Quantity and Section Area | qty x mm ² | n/a | 4 x 25 |
| | qty x AWG | | 4 x 4 |
| Cable Length | meter | n/a | n/a |
| | feet | | |
| Gas Models | | | |
| Circuit Breaker | ampere | 3 x 10 | 3 x 10 |
| Cable Quantity and Section Area | qty x mm ² | 4 x 2.5 | 4 x 2.5 |
| | qty x AWG | 4 x 14 | 4 x 14 |
| Cable Length | meter | 30 | 30 |
| | feet | 98.4 | 98.4 |

Table 17 Cable and Fuse Values for 480V Three-Phase Voltage

CABLE AND FUSE VALUES OF THE 35XX SERIES

| 35XX SERIES CABLE AND FUSE VALUES FOR 240V THREE-PHASE VOLTAGE | | | |
|--|-----------------------|---------|---------|
| | Unit | TFI3516 | TFI3521 |
| Gas Models | | | |
| Circuit Breaker | ampere | 3 x 10 | 3 x 10 |
| Cable Quantity and Section Area | qty x mm ² | 4 x 4 | 4 x 4 |
| | qty x AWG | 4 x 12 | 4 x 12 |
| Cable Length | meter | 18 | 14 |
| | feet | 59 | 45.9 |

Table 18 Cable and Fuse Values for 240V Three-Phase Voltage

| 35XX SERIES CABLE AND FUSE VALUES FOR 380V THREE-PHASE VOLTAGE | | | |
|--|-----------------------|---------|---------|
| | Unit | TFI3516 | TFI3521 |
| Electric Models | | | |
| Circuit Breaker | ampere | n/a | 3 x 63 |
| Cable Quantity and Section Area | qty x mm ² | n/a | 4 x 10 |
| | qty x AWG | | 4 x 8 |
| Cable Length | meter | n/a | n/a |
| | feet | | |
| Gas Models | | | |
| Circuit Breaker | ampere | 3 x 10 | 3 x 10 |
| Cable Quantity and Section Area | qty x mm ² | 4 x 2,5 | 4 x 2,5 |
| | qty x AWG | 4 x 14 | 4 x 14 |
| Cable Length | meter | 30 | 30 |
| | feet | 98.4 | 98.4 |

Table 19 Cable and Fuse Values for 380V Three-Phase Voltage

| 35XX SERIES CABLE AND FUSE VALUES FOR 480V THREE-PHASE VOLTAGE | | | |
|--|-----------------------|---------|---------|
| | Unit | TFI3516 | TFI3521 |
| Electric Models | | | |
| Circuit Breaker | ampere | n/a | 3 x 63 |
| Cable Quantity and Section Area | qty x mm ² | n/a | 4 x 10 |
| | qty x AWG | | 4 x 8 |
| Cable Length | meter | n/a | n/a |
| | feet | | |
| Gas Models | | | |
| Circuit Breaker | ampere | 3 x 10 | 3 x 10 |
| Cable Quantity and Section Area | qty x mm ² | 4 x 2,5 | 4 x 2,5 |
| | qty x AWG | 4 x 14 | 4 x 14 |
| Cable Length | meter | 30 | 30 |
| | feet | 98.4 | 98.4 |

Table 20 Cable and Fuse Values for 480V Three-Phase Voltage

STEAM INFORMATION

The steam supply lines have to be connected to the "Steam Inlet" marked with the "Steam" sticker. Its placement is designated on the "Locations of the Labels on the Machine" section on p.23 and p.24. The steam return lines have to be connected to the "Condense Output" marked with the "Steam Condensate" sticker. Its placement is designated on the "Locations of the Labels on the Machine" section on p.23 and p.24.



Fig. 25 Steam Sticker



Fig. 26 Steam Condensate Sticker



NOTE

It is the responsibility of the equipment owner to have all steam plumbing connections made by a qualified professional to ensure that the installation is adequate and conforms to local and country (state) regulations and codes.

Failure to comply with the requirements stipulated in this manual can result in component failure, which will void the warranty.

Installation Instructions for Steam Supply Lines and Steam Return Lines



NOTE

To ensure an adequate supply of steam is provided, be sure that the steam supply lines and the steam return lines are sized and laid out as stipulated in this manual. Inadequate steam supply lines and steam return lines or improper steam plumbing will result in poor performance and cause component failure. Clean, dry steam must be provided to the ironer.



CAUTION

Steam roller jet failure due to water hammer by wet steam will void the warranty.

The presence of condensate in the steam supply line will cause water hammer and subsequent ironer roller failure. The supply connection into the main supply line must be made with a minimum 25 cm (9.84 in) rise. This will prevent any condensate from draining towards the roller.

The steam supply line to the ironer must include a 30 cm (11.8 in) riser along with a check valve. This will prevent any condensate from entering the roller.



CAUTION

Water pockets in the supply line caused by low points, will provide wet steam to the roller possibly causing steam roller damage.

It is obligatory to use STRAINERS for all water and steam inlets.



NOTE

A shutoff valve for each ironer should be installed in the supply line, return line. This will allow the ironer to be isolated from the supply line and the return line if the ironer needs maintenance work.

A vacuum breaker should be installed onto the steam lines. This will save energy and provide for the safety of the operator and maintenance personnel.

Install a check valve at least 30 cm (11.8 in) below each steam return line as close to the roller as possible.

STEAM CONNECTIONS (ONLY STEAM HEATED MACHINES)

The working pressure for steam heated ironers is maximum 6 bars. Refer to the "Machine Datasheet"s located on p.6-10 for detailed working pressure data.



For steam installations the pipes must be aligned with %1 incline in the same direction of steam flow.

The pipes must have a condenser at every 30-50 m (98-164 ft). At this point the pipe is elevated about 30-40 cm (11.8-15.7 in) and condense is taken from below.

The most effective points for drainage are the points where the pipes change direction.

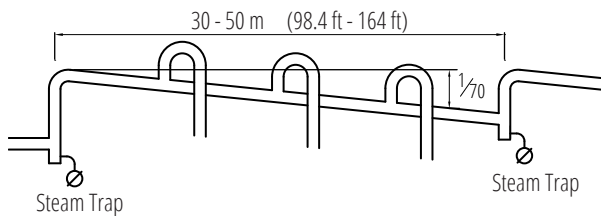

Fig. 27 Main Steam Line Condense Point and Elevation Diagram



Spherical Valves must not be used for steam installations.

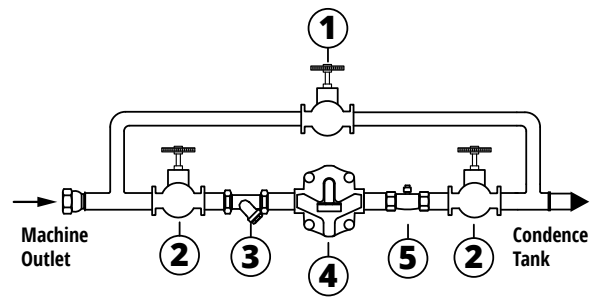

Fig. 28 Flatwork Ironer Condenser Connection Detail

| | |
|---|-------------------|
| 1 | Steam Bypass Vane |
| 2 | Steam Line Vane |
| 3 | Strainer |
| 4 | Steam Trap |
| 5 | Check Valve |

Table 21 Flatwork Ironer Condenser Connection Diagram Component List

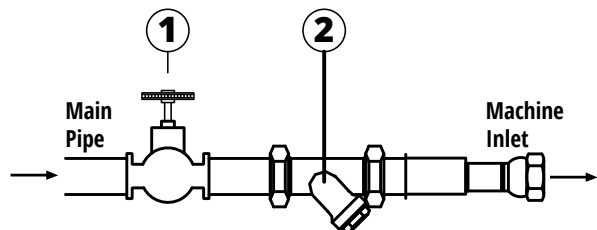

Fig. 29 Flatwork Ironer Steam Connection Detail

| | |
|---|-----------------|
| 1 | Steam Line Vane |
| 2 | Strainer |

Table 22 Flatwork Ironer Steam Connection Diagram Component List

GAS INFORMATION



It is the responsibility of the equipment owner to have all plumbing connections made by a qualified professional to ensure that the gas plumbing installation is adequate and conforms with local and country (state) regulations or codes.

Failure to comply with these codes or ordinances, and/or the requirements stipulated in this manual, can result in personal injury and improper operation of the ironer.

Gas Supply



The gas heated ironer installation must meet the national gas code, as well as local codes and ordinances and must be done by a qualified professional.



Undersized gas piping will result in ignition problems, slow ironing, increased use of energy, and create a safety hazard. (EN746-2 / 5.2.1.1) (TS10472-5 / 5.6)



The ironer must be connected to the type of heat/gas indicated on the ironer label. If this information does not agree with gas type available, do not operate the ironer.

Contact the reseller who sold the ironer or contact the manufacturer.

Any burner changes or conversions must be made by a qualified professional.



The gas heated ironer is not provided with an internal gas supply shutoff and an external shutoff must be provided.

The gas heated ironer is not supplied with an external gas filter. Gas filter must be provided.

Undersized gas piping can create a low or inconsistent pressure, which will result in erratic operation of the burner ignition system.



Never test for leaks with a flame.



Test all connections for leaks by brushing on a soapy water solution onto them.

The ironer must be isolated from the gas supply piping system by closing its individual shutoff valve during any pressure test of the gas supply system at test pressures equal to or less than 350 mbar (3.5 kPa) (5.07 psi).

INITIAL START UP OF THE MACHINE

The first operation of the product must be done by the Authorized Technical Service.

It is highly recommended to have the following measuring devices available to monitor the machine during the initial start-up:

| |
|--|
| Multimeter Reading range: from 0 to 1,000v AC. |
| Clamp ammeter Reading range: higher than 300A AC. |
| Pressure gauge with flexible pipe outlet Capable of measuring pressure and suction. |
| Flue gas analyser Suitable for the analysis required to comply with the legislation in the country where the ironer is installed. |

Table 23 Required Measuring Devices for Initial Start-Up

INITIAL CHECKS

- Check that the ironer is properly leveled in its final location.
- Check that all the machine's covers are fitted and secured correctly.
- Check that the installation details relating to the sources of energy (electric and gas) match those on the machine's specification nameplate.
- Check that the vents and the extraction ducts are constructed as described in the "**Exhaust Requirements**" section of this manual.
- Use the "**Crank Handle**" to manually rotate the cylinder and check that the cylinder rotates properly (Check the "**Machine Operation**" section)
- Open the manual valve for the gas supply circuit (depending on machine model).
- Connect the switch breaker.
- Start up the machine and select a program with a high temperature (approx. 100°C / 200°F) that will cause the heating system to turn on (see instructions in "**Control Panel Instructions**" section).
- Check that the heating system is connected properly.
 - **Machines with gas heating**
Check through the viewer in the side cover that the burner lights up along its length, and that the flame is blue, stable and uniform. If this is not the case, stop the ironing program immediately.
 - **All models**
Check that the power consumption is in agreement with the values set out in the "**Machine Datasheet**".
- If any anomaly is detected, stop the ironer immediately, disconnect the power supply and the gas inputs and inspect the installation.
- Stop the machine operation by pressing the STOP key and

check that the heating system has been disconnected. On machines with gas heating, check that the burner flame is completely extinguished.

GAS PRESSURE CONTROL ON GAS MODELS

When the dryer is first started during initial start up, the burner has a tendency **not to ignite** at the first attempt. This is because the gas supply piping is filled with air. So it may take a few minutes for this air to be purged from the lines. During the purging period check to be sure that all gas shutoff valves are open.

The dryer is equipped with a direct spark ignition system, which has internal diagnostics. If ignition is not established after 3 attempts the heat circuit module will lock out until it is manually reset. To reset the system press the reset button on the dryer.

Once ignition is established a gas pressure test should be taken at the gas valve pressure tap of each dryer to ensure that the pressure is correct and consistent.

ANALYSIS OF THE COMBUSTION GASES ON GAS MODELS

Once the ironing program has begun;

- Wait a few minutes until the fume exit temperature exceeds 120 °C (248 °F).
- Analyse the combustion products (**Photo 2**). The result must comply with the requirements in force in the country where the ironer is installed.
- Some operating conditions may call for a slight modification of the combustion control devices.

See:

- Changing the position of the air extraction adjustment clapper valve

- Replace the cover of the base-frame and connect the electricity and gas supply.
- Repeat the initial test and analyse the combustion products described as in the "**Analysis of Combustion Gases**" section.
- Repeat the operations described as many times as necessary in order to achieve combustion values consistent with the current requirements in the country where the ironer is installed.

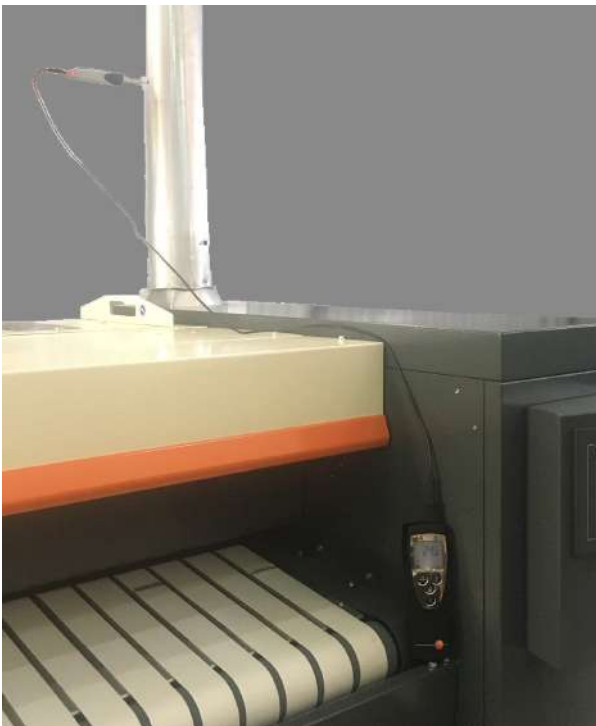

Photo 2 Analysis of Combustion Gases

Changing the position of the air extraction adjustment clapper valve

- Stop the machine.
- Switch off or close and mechanically lock the power supply and the manual gas inlet valve.
- Wait a reasonable time to ensure that there are no high temperature surfaces inside the base-frame.
- Remove the left-hand side cover from the base-frame and check that the surface temperature of the air output is not at a dangerous level. Loosen the locknut and adjust the position of the air flow clapper valve (Fig. 36).
 - Turn the stem of the clapper valve in the + direction to open up the flow of fumes.
 - Turn the stem of the clapper valve in the – direction to close the flow of fumes.
- Tighten the locknut to lock the position of the clapper valve.

CONTROL PANEL INSTRUCTIONS

STARTUP INSTRUCTIONS

There are certain preparational procedures before the control panel gets ready to be used when the machine is powered on. These procedures are listed below:

1. Startup Screen Step



Fig. 30 TFI Controller Startup Screen

The controller will initially display the "Startup Screen" when it is powered on.

You should touch on the screen to continue the startup sequence and proceed to the next step. The controller will wait and continue to display the startup screen until the operator touches the touchscreen..

2. Hand Protection Guard Check Step



Fig. 31 TFI Hand Protection Guard Check Screen

The "Hand Protection Guard" which is the most important safety mechanism of the ironer, has to be checked on each startup of the controller.

You must press on the hand protection guard to proceed to the main menu.

If the controller software does not proceed to the "Main Menu" when you press on the hand protection guard then **1.**

it means that this mechanism has a failure. In this case you **MUST** power off the machine, shut off the gas valves and call the Authorized Technical Service company for assistance.

MAIN MENU WINDOW

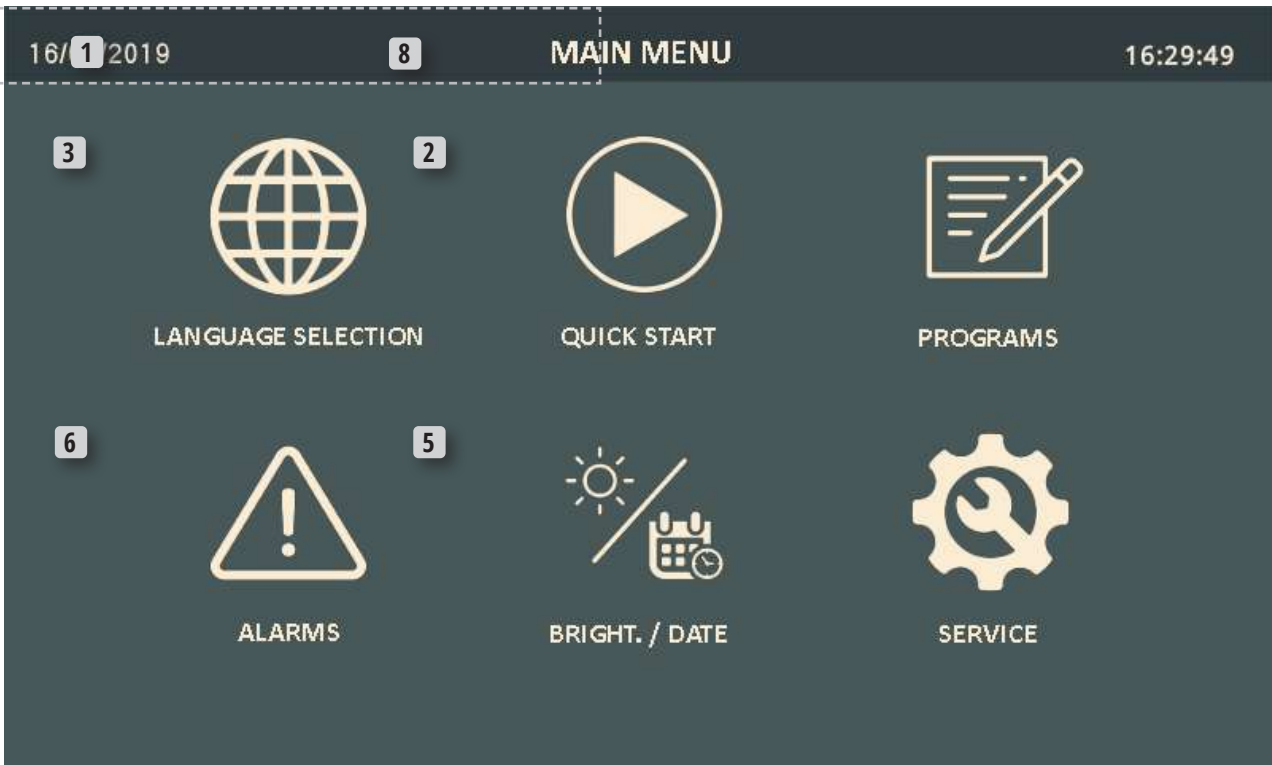

Fig. 32 Main Menu Window

- 1 **Menu Name Bar:** The top bar of the controller screen displays the name of the menu window.
- 2 **Language Selection Menu Button:** Enters the "Language Selection" sub menu.
- 3 **Program Quick Start Button:** Starts the last executed program.
- 4 **Program Selection Menu Button:** Enters the "Program Selection" sub menu.
- 5 **Alarm Menu Button:** Enters the "Alarm" sub menu.
- 6 **Brightness and Date Menu Button:** Enters the "Brightness and Date Settings" sub menu.
- 7 **Service Menu Button:** Enters the "Service" sub menu.
- 8 **System Date:** Displays the current date.
- 9 **System Time:** Displays the current time.

Table 24 Main Menu Content List

USER INTERFACE

States of Buttons

The buttons located on various windows can have two different states; they can either be activated or deactivated. Each state is indicated with the color of the circle on the top right corner of the button icon which does change its color between background gray and red depending on the state of the button.



| | |
|---|---|
|  | The red colored circle indicates that the button/function is activated . |
|  | The background gray colored circle indicates that the button/function is deactivated . |

Table 25 Button States

A button will change the color of its circle between background gray and red when it's pressed.

States of the Burner State Icon

The burner icon which is located on the program window has three different states; it can either be in the "ignited" state, the "activated" state or the "passive" state. Each state is indicated with the color of the circle in the middle of the burner icon and the color of the flame icon which do change their color between background gray and red depending on the state of the button.



| | |
|---|---|
|  | The colored flame shape and red colored circle indicate that the burner is in the ignited state. |
|  | The uncolored flame shape and red colored circle indicate that the burner is in the active state. |
|  | The uncolored flame shape and the background gray colored circle indicate that the burner is in the passive state. |

Table 26 Burner Icon States

The burner icon will change the color of its circle and its flame between background gray and red when it's pressed.

MAIN MENU INSTRUCTIONS

The main menu window contains various options to operate, diagnose and set the ironer and also options about the controller itself.

The top bar always displays the name of the current active menu and also contains the current system date and time information.

Pressing on the buttons on the main menu will either enter some sub function menus or directly start a program (The **"Quick Start"** button).

The functions of these sub menus are explained in the following sections. These menus are :

1. Language Selection Menu
2. Quick Start Button / Program Execution Window
3. Programs Menu
4. Alarms Menu
5. Brightness and Date Menu
6. Service Menu

1. LANGUAGE SELECTION MENU

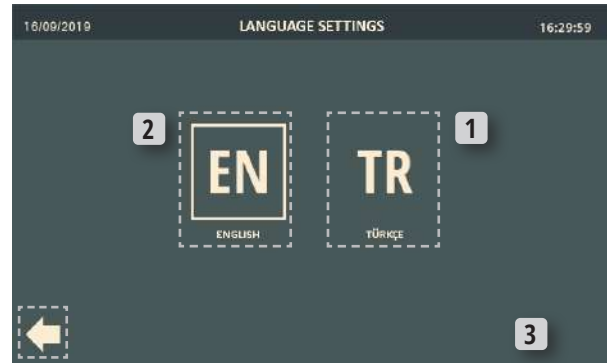

Fig. 33 Language Selection Menu

- 1 English Language Button:** Sets the controller interface language to "English".
- 2 Turkish Language Button:** Sets the controller interface language to "Turkish".
- 3 Back Button:** Exits back to the "Main" menu.

Table 27 Language Selection Menu Content List

This menu is used to set the interface language of the controller.

To set the interface language :

- Press on the target language button

The controller will change the interface language and return back to the main menu after pressing the target language button.

You can press on the "Back" button to go back to the main menu if you don't want to change the interface language.

2. QUICK START BUTTON / PROGRAM EXECUTION WINDOW

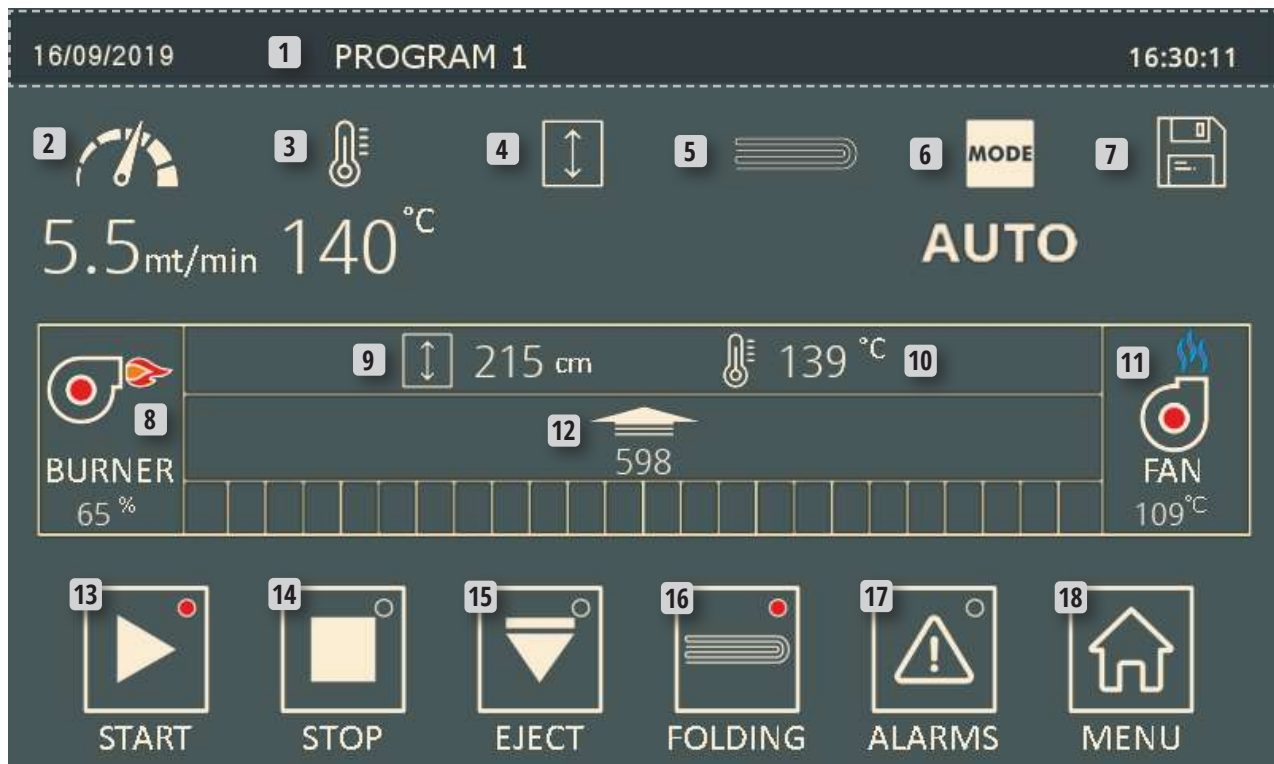

Fig. 34 Quick Start Button / Program Execution Window on TFI6026 and TFI6032 models

- | | |
|---|--|
| <p>1 Program Name Bar: The top bar of the "Program Execution Window" displays the name of the selected program.</p> <p>2 Ironing Speed Icon and Value: Displays the set target ironing speed of the selected program.</p> <p>3 Roller Temperature Icon and Value: Displays the set target roller temperature of the selected program.</p> <p>4 Roller Direction: Sets the direction of the roller movement.</p> <p>5 Folding Count: Sets the number of the linen folds.</p> <p>6 Folding Mode: Sets the mode of folding.</p> <p>7 Save Button: Saves the changes made to the program.</p> <p>8 Burner State Icon and Temperature Value: Controls the burner activation and displays its PID value.</p> <p>9 Ironed Linen Length: The length of the last processed linen.</p> | <p>10 Roller Temperature: The current temperature of the roller.</p> <p>11 Exhaust Temperature: The current temperature of the exhaust.</p> <p>12 Total Linen Count: The total linen count sensed by the sensors since the last reset.</p> <p>13 Program Start Button: Starts the current program.</p> <p>14 Program Stop Button: Stops the current program.</p> <p>15 Eject Button: Activates the output conveyor.</p> <p>16 Folding Button: Controls the activation of the folding feature.</p> <p>17 Alarm List Button: Single press acknowledges the active alarms. Long press switches to the alarm list.</p> <p>18 Main Menu Button: Switches to the main menu.</p> |
|---|--|

Table 28 Program Execution Window Component List

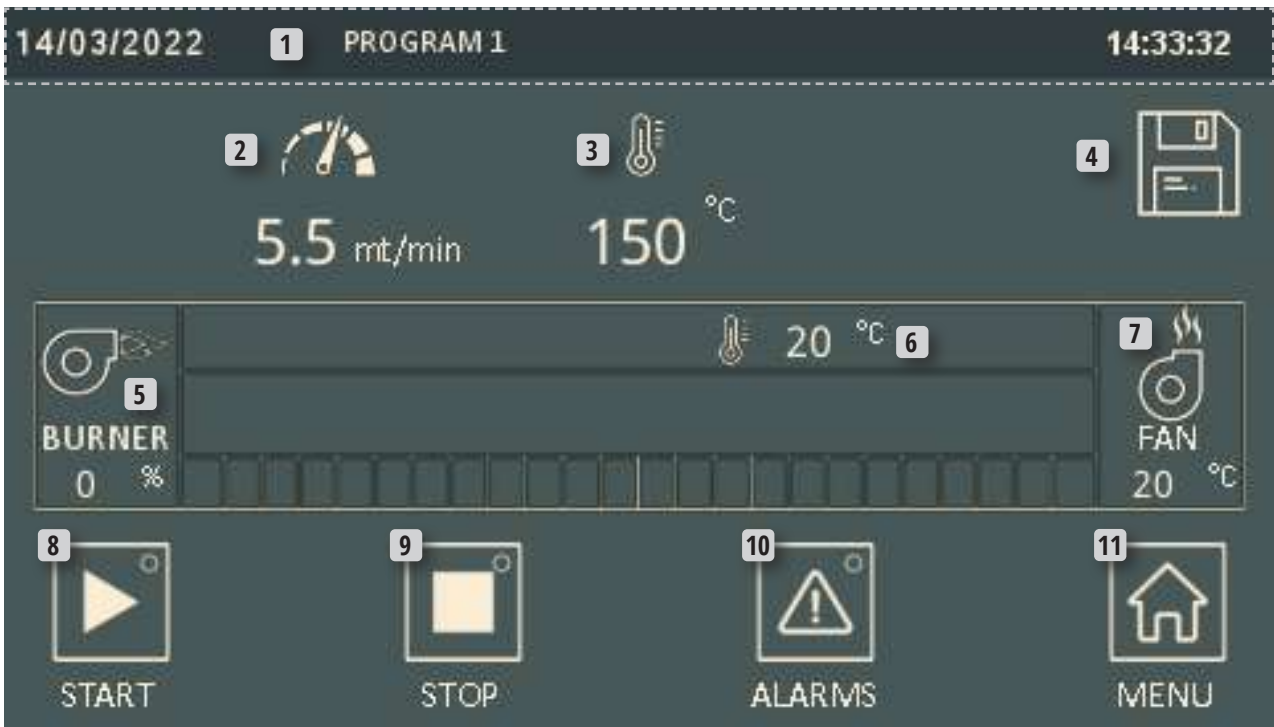

Fig. 35 Quick Start Button / Program Execution Window on TFI3516 and TFI3521 models

- | | |
|--|---|
| <p>1 Program Name Bar: The top bar of the "Program Execution Window" displays the name of the selected program.</p> <p>2 Ironing Speed Icon and Value: Displays the set target ironing speed of the selected program.</p> <p>3 Roller Temperature Icon and Value: Displays the set target roller temperature of the selected program.</p> <p>4 Save Button: Saves the changes made to the program.</p> <p>5 Burner State Icon and Temperature Value: Controls the burner activation and displays its PID value.</p> <p>6 Roller Temperature: The current temperature of the roller.</p> <p>7 Exhaust Temperature: The current temperature of the exhaust.</p> | <p>8 Program Start Button: Starts the current program.</p> <p>9 Program Stop Button: Stops the current program.</p> <p>10 Alarm List Button: Single press acknowledges the active alarms. Long press switches to the alarm list.</p> <p>11 Main Menu Button: Switches to the main menu.</p> |
|--|---|

Table 29 Program Execution Window Component List

2.1 PROGRAM EXECUTION WINDOW INSTRUCTIONS

The controller will switch to the "Program Execution" window when the "Quick Start" button on the "Main Menu" is pressed. The same function can also be achieved by selecting a program from the "Programs Menu" and pressing the "Select Program" button.

The "Quick Start" button on the "Main Menu" directly selects the last executed program. (This button will select the first program on the program list on the initial run of the ironer).

The controller won't automatically start the selected program when you enter the program execution window. The program execution and termination has to be controlled by an operator.

Please refer to the "Program Execution" section for further details of this function.

2.2 PROGRAM OPTIONS

Programs can be customized on the "Program Execution" screen before starting a program. Program customizations can be saved onto the selected program itself or as a new program.

The features (or parameters) which can be customized are listed and instructed below.

2.2.1 Program Name

- Press on the program name on the screen. This action will open a virtual alphanumeric keyboard window and a text entry box.
- Type the new name of the program by utilizing the virtual keyboard.



Fig. 36 Virtual Keyboard for Program Name Entry

- Press the "Enter" key to save your modifications.

2.2.2 Ironing Speed

- Press on the "Ironing Speed" icon on the screen. This action will open a numerical virtual keyboard window and a number entry box. The limits for the value will be displayed below the entry box.
- Type the new value for the ironing speed by utilizing the virtual keyboard. The values will be accepted up to their tenth digit and won't be rounded.



Fig. 37 Virtual Keyboard for Ironing Speed Entry

- Press the "Enter" key to save your modifications.

2.2.2.1 Notes on Ironing Speed

- All of the factory programs do have the ironing speed of 5.5 m/min.
- The ironing speed on programs which utilize the "Folding" feature can only be set between the limits of 3.5 m/min and 6.5 m/min. The ironing speed on programs which do not utilize the "Folding" feature (*No Fold*) can be set between the limits of 2 m/min and 12 m/min.

2.2.3 Roller Temperature

Setting the temperature of the roller will determine the target ironing temperature of process.

- Press on the "Roller Temperature" icon on the screen. This action will open a numerical virtual keyboard window and a number entry box. The limits for the value will be displayed below the entry box.
- Type the new value for the roller temperature by utilizing the virtual keyboard. You can't enter decimal values, but can only enter whole numbers. The limits for the roller temperature are between 0 °C and 170 °C.



Fig. 38 Virtual Keyboard for Roller Temperature Value Entry

- Press the "Enter" key to save your modifications.

2.2.4 Folding Mode

This function is only available on the TFI6026 and TFI6032 models.

- Press on the "Folding Mode" button on the screen. This action will open the "Folding Mode Selection" window.



Fig. 39 Folding Mode Selection Window

- Press the on the target mode button to select it. All of the factory programs are set as "Automatic".

In the "Automatic" mode, the machine will automatically measure the length of the linen and utilize the smallest possible length for each fold. This mode is most suitable for linen which have non-standard sizes.

In the "Semi-Automatic" mode, the length of the linen will be recorded into the program and the controller will select the least folds automatically based on this value.

In the "Manuel" mode, both the length of the linen and also the possible fold counts corresponding to this length value have to be manually recorded into the program.

- If you did select one of the "Semi-Automatic" or "Manuel" modes then you will be presented with the "Length Entry" window. Press on the "Length Value" to modify the current value. This action will open a numerical virtual keyboard window and a number entry box. The limits for the value will be displayed below the entry box.
- Type the new value for the linen length by utilizing the virtual keyboard. You can't enter decimal values, but can only enter whole numbers. The limits for the linen length are between 50 cm and 400 cm.
- Press the "Enter" key to save your modifications.



Fig. 40 Folding Length Value Entry

- You have to approve the modified value after finishing the value entry process. Press on the "Approval" button at the bottom of the "Folding Length Value Approval Window".

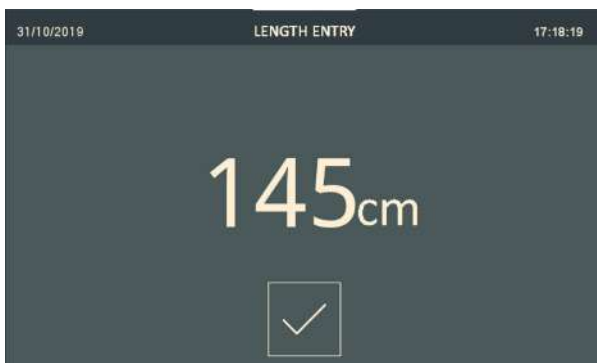

Fig. 41 Folding Length Value Approval Window

- If you did select the "Manuel" mode then you will be presented with the "Folding Count Entry" window. Select and press on the target fold count that you want to achieve. Only the available fold count buttons based on the linen length value will be presented and active. The rest of the count buttons will be inactive.



Fig. 42 Folding Count Entry Screen

2.2.4.1 Linen Fold-Length Table and Graphs

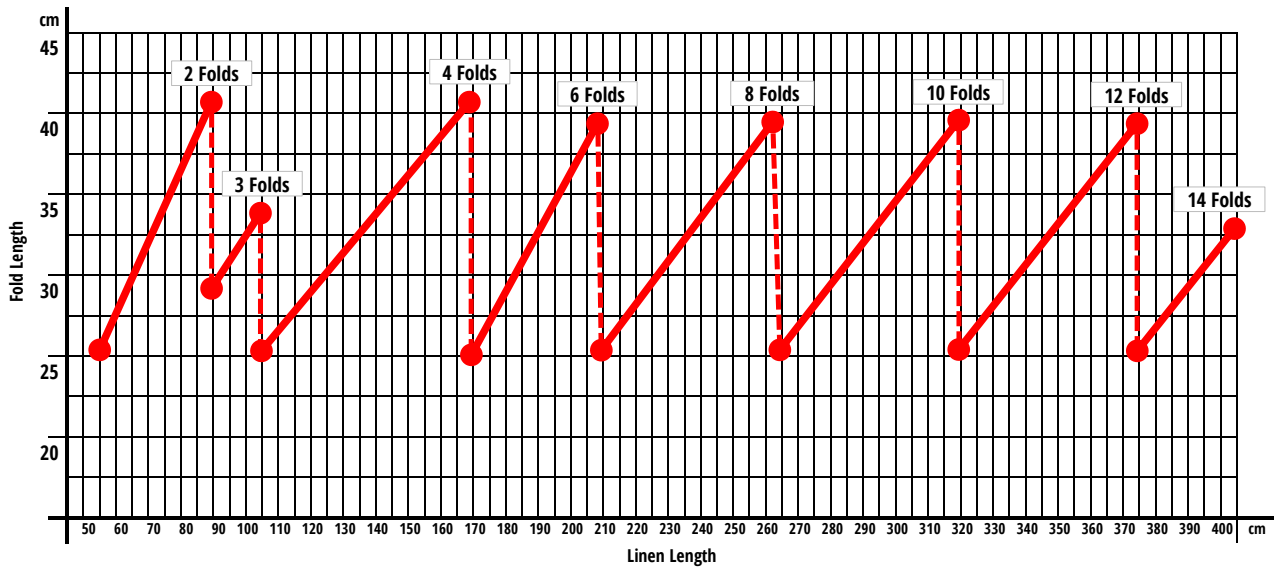

Fig. 43 Linen-Fold Length Graph for Automatic Mode

| Fold Count | Linen Length (cm) | Fold Length (cm) |
|------------|-------------------|------------------|
| 2 | 50-82 | 25-41 |
| 3 | 83-99 | 28-33 |
| 4 | 100-162 | 25-41 |
| 6 | 163-202 | 25-39 |
| 8 | 203-257 | 25-39 |
| 10 | 258-313 | 25-39 |
| 12 | 314-369 | 25-39 |
| 14 | 370-400 | 25-33 |

Table 30 Linen-Fold Length Table for Automatic Mode

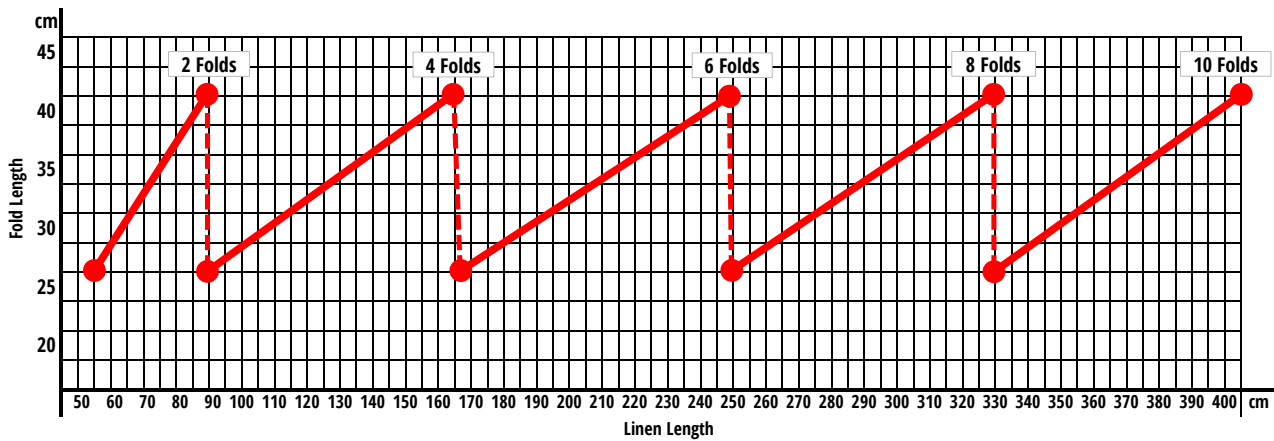

Fig. 44 Linen-Fold Length Graph for Semi Automatic Mode

| Fold Count | Linen Length (cm) | Fold Length (cm) |
|------------|-------------------|------------------|
| 2 | 50-82 | 25-41 |
| 4 | 83-160 | 25-41 |
| 6 | 161-242 | 25-41 |
| 8 | 243-324 | 25-41 |
| 10 | 325-400 | 25-41 |

Table 31 Linen-Fold Length Table for Semi Automatic Mode

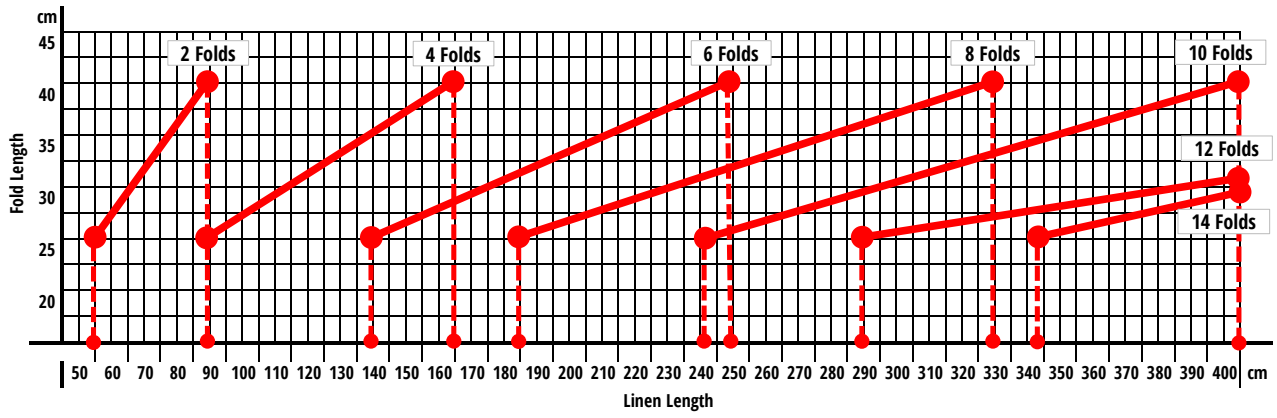

Fig. 45 Linen-Fold Length Graph for Manual Mode

| Fold Count | Linen Length (cm) | Fold Length (cm) |
|------------|-------------------|------------------|
| 2 | 50-82 | 25-41 |
| 4 | 82-160 | 25-40 |
| 6 | 133-242 | 25-40 |
| 8 | 178-324 | 25-41 |
| 10 | 236-400 | 25-40 |
| 12 | 284-400 | 25-33 |
| 14 | 336-400 | 25-29 |

Table 32 Linen-Fold Length Table for Manual Mode

2.2.5 Non-Folding Mode

This function is only available on the TF16026 and TF16032 models.

You can disable the folding feature of the machine in case you don't need to fold the linen. The lever of the retractable output tray has to be pushed forward when the folding feature is disabled in a program. The controller will warn the operator about this action when the folding feature is turned off for the first time.



Fig. 46 The retractable tray warning message

- Press on the "Folding" button on the screen. This action will disable the "Folding" feature. The text below the "Folding Mode" icon will switch to "NO FOLD" and the controller will display the warning message which states "Push forward the laundry basket lever". This message will be displayed for 5 seconds and then disappear. At this stage, the operator has to set the position of the lever accordingly.

2.3 PROGRAM MODIFICATION

The controller has 40 programs in total. By default all of the programs are created with the same settings. You can modify the options of the programs by selecting them in the "Programs" menu and then saving the modifications into them.

If you use a modified program without saving the modifications then those modifications will be utilized temporarily and they will be defaulted back to the original settings on the next run of the program.

2.3.1 Saving A Program

- Press and hold the "Save Button" for 3 seconds. The "Saved" text will be displayed in the informational dialog box and the modified program will be saved into the programs list.



Fig. 47 Program Save Confirmation Dialog Box

2.4 PROGRAM EXECUTION

- Press the "Start" button to start the selected program.

You should wait for the cylinder temperature to raise to the target temperature before starting to feed the linen into the ironer. The machine will indicate that the cylinder has reached the target temperature by turning on the feeding indicator lights. Also the operator can observe the current temperature of the roller on the "Roller Temperature" indicator.

You can feed the ironer continuously without stopping the program by modifying the program options until the end of the day/cycle. The ironer will continue to operate until the program is stopped by the operator.

The modifications on the program options will immediately be executed during program execution.

The operator has to be aware that changing the target temperature of the roller during program execution can't be applied instantly to the roller. In these cases the operator should wait for the roller to reach the new temperature value before feeding linen into the ironer.

You can directly switch to another program whilst the ironer is executing a program by selecting a different program on the "Programs" menu. The same rules from above do apply for switching programs.

- Press the "Stop" button to stop the running program.

Stopping a program won't stop the cylinder immediately. The cylinder has to be cooled off before completely stopping its action because the heat has to be dissipated to save the belts from heat hazards. The controller will continue to drive the cylinder until it reaches the safe temperature. The controller will completely stop the cylinder when the safe temperature has been reached.



Do not shut off the mains power of the machine to end its action instantly when the program has been stopped.

The belts will get damaged if the temperature of the roller hasn't been cooled down to the safe temperature after stopping a program.

3. PROGRAMS MENU



Fig. 48 Program Selection Menu

- 1 Program Selection Button:** Sets the active program to the selected program on the "Program List".
- 2 Program Deletion Button:** Deletes the selected program on the "Program List".
- 3 Back Button:** Exits back to the "Main" menu.
- 4 Previous Page Button:** Switches to the previous page on the "Program List".
- 5 Page Number:** Displays the current page on the "Program List".
- 6 Next Page Button:** Switches to the next page on the "Program List".
- 7 Program List:** Lists the programs by program number.

Table 33 Program Selection Menu Component List

The "Programs" menu is used to select a program to run and present it on the "Program Execution Window".

4. ALARMS MENU



Fig. 49 Alarm List Menu

- 1 **Next Button:** Switches to the next page on the "Alarm List".
- 2 **Back Button:** Exits back to the "Main" menu.
- 3 **Previous Page Button:** Switches to the previous page on the "Alarm List".
- 4 **Alarm List:** Lists the triggered alarms by alarm number..

Table 34 Alarm List Menu Component List

5. BRIGHTNESS AND DATE MENU



Fig. 50 Brightness and Date/Time Settings Menu

- 1 **Brightness Setting Button:** Opens the "Brightness Setting" window.
- 2 **Date/Time Setting Button:** Opens the "Date/Time Setting" window.
- 3 **Back Button:** Exits back to the "Main" menu.

Table 35 Brightness and Date/Time Menu Component List

5.1 Brightness Setting Window



Fig. 51 Brightness Setting Window

- 1 **Brightness Setting Slider:** Sets the brightness of the screen.
- 2 **Back Button:** Exits back to the "Brightness and Date/Time Setting" menu.

Table 36 Brightness Setting Window Component List

5.2 Date/Time Setting Window



Fig. 52 Date/Time Setting Window

- 1 **Year/Month/Day Setting Cells:** Sets and displays the current year/month/day value of the controller.
- 2 **Hour/Minute/Second Setting Cells:** Sets and displays the current hour/minute/second value of the controller.
- 3 **Selected Cell:** Activates the selected part of the date/time setting.
- 4 **Back Button:** Exits back to the "Brightness and Date/Time Setting" menu.

Table 37 Date/Time Setting Window Component List

6. SERVICE MENU

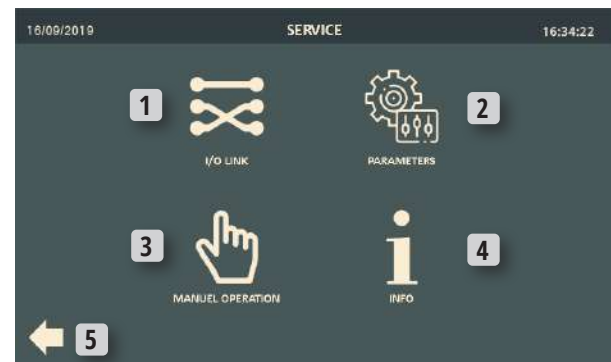

Fig. 53 Service Menu

- 1 **I/O Link Menu Button:** Enters the "I/O Link" sub menu.
- 2 **Parameters Menu Button:** Enters the "Parameters" sub menu.
- 3 **Manuel Operation Menu Button:** Enters the "Manuel Operation" sub menu.
- 4 **Info Menu Button:** Enters the "Info" sub menu.
- 5 **Back Button:** Exits back to the "Main" menu.

Table 38 Service Menu Component List

6.1 I/O LINK MENU

The "I/O Link Menu" displays the digital input and output sensors for troubleshooting purposes.

The menu will by default display the digital inputs screen. This screen also includes the reading values of the temperature sensors.

You can switch to the digital outputs screen by pressing the "Next" button.

6.1.1 Digital Inputs Window

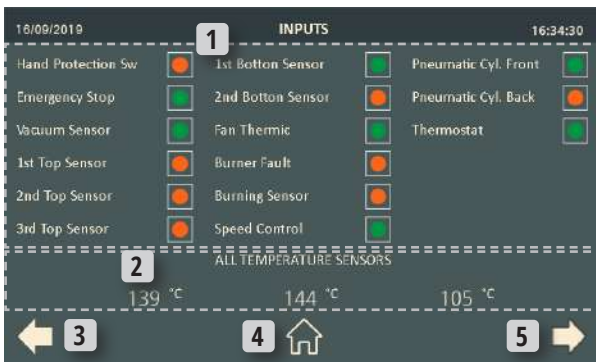

Fig. 54 I/O Link Menu Digital Inputs Window on TFI6026/TFI6032 models

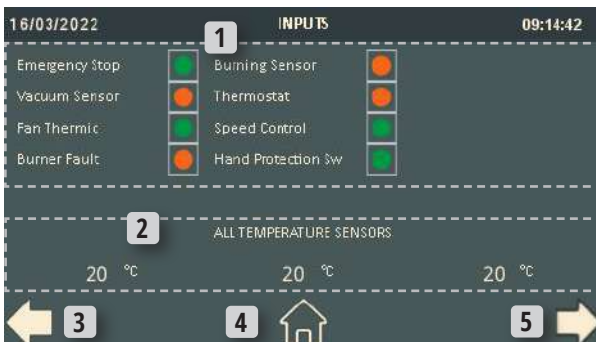

Fig. 55 I/O Link Menu Digital Inputs Window on TFI3516/TFI3521 models

- 1 Digital Inputs List:** Displays the status of the digital inputs.
- 2 Temperature Sensors List:** Displays the reading values of the temperature sensors.
- 3 Back Button:** Exits back to the "Service" menu.
- 4 Home Button:** Exits back to the "Main" menu.
- 5 Next Button:** Switches to the "Digital Outputs" window.

Table 39 Digital Inputs Window Component List

This menu displays the values of the digital inputs. When any of the switches, sensors and other types of input devices are triggered then their icon will be displayed with a green circle.

| |
|--|
| Top Sensors |
| Bottom Sensors |
| Piston Backward Switch |
| Piston Forward Switch |
| Emergency Stop Reads the status of the Emergency Stop Button. It's located on the ESB board. |
| Vacuum Sensor Reads the status of the vacuum sensor. |
| Fan Thermic |
| . |
| Burner Fault |
| . |
| Burning Sensor |
| . |
| Thermostat |
| . |
| Speed Control |
| . |
| Hand Protection Switch Reads the status of the Hand Protection Bar and is located below the handle bar. See Fig.xx on p.xx for details. |

Table 40 Digital Input Descriptions

| |
|---|
| Roller Temperature Sensor 1 Reads the temperature value of the roller sensor positioned on the burner side of the roller (right side of the ironer). |
| Roller Temperature Sensor 2 Reads the temperature value of the roller sensor positioned on the middle side of the roller (middle side of the ironer). This sensor is an optional sensor so its value will be displayed only if it's installed on the actual machine. |
| Roller Temperature Sensor 3 Reads the temperature value of the roller sensor positioned on the fan side of the roller (left side of the ironer). |

Table 41 Temperature Sensor Descriptions

6.1.2 Digital Outputs Window



Fig. 56 I/O Link Menu Digital Outputs Window on TFI6026/TFI6032 models

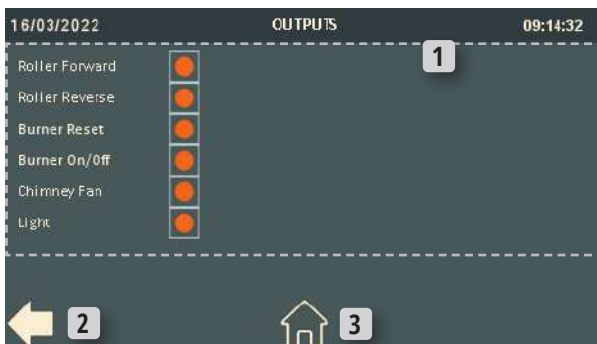

Fig. 57 I/O Link Menu Digital Outputs Window on TFI3516/TFI3521 models

- 1 Digital Outputs List:** Displays the status of the digital outputs.
- 2 Back Button:** Exits back to the "Digital Inputs" menu.
- 3 Home Button:** Exits back to the "Main" menu.

Table 42 Digital Outputs Window Component List

| |
|--|
| Roller Motor Forward Rotation Signal Displays the status of the roller motor forward rotation signal output. |
| Roller Motor Reverse Rotation Signal Displays the status of the roller motor reverse rotation signal output.. |
| Burner Reset Signal Displays the status of the burner reset signal output. |
| Clutch Coil Displays the status of the clutch coil signal output. |
| Burner Activation Signal Displays the status of the burner activation signal output. |
| Chimney Fan Activation Signal Displays the status of the chimney fan activation signal output. |
| Piston Forward Action Signal Displays the status of the piston forward action signal output. |

| |
|---|
| Piston Reverse Action Signal Displays the status of the piston reverse action signal output. |
| Lamp 1 Signal Displays the status of the lamp 1 signal output. |
| Lamp 2 Signal Displays the status of the lamp 2 signal output. |
| Lamp 3 Signal Displays the status of the lamp 3 signal output. |

Table 43 Digital Output Descriptions

6.2 PARAMETERS MENU



Fig. 58 Parameters Menu on TFI6026/TFI6032 models



Fig. 59 Parameters Menu on TFI3516/TFI3521 models

- 1 **Setup Parameters Menu Button:** Enters the "Setup Parameters" sub menu.
- 2 **Burner Parameters Menu Button:** Enters the "Burner Parameters" sub menu.
- 3 **Clutch Parameters Menu Button:** Enters the "Clutch Parameters" sub menu.
- 4 **Folding Parameters Menu Button:** Enters the "Folding Parameters" sub menu.
- 5 **Back Button:** Exits back to the "Service" menu.
- 6 **Home Button:** Exits back to the "Main" menu.

Table 44 Parameters Menu Component List

The "Parameters" menu monitors the parametric function values of various subsystems of the controller and the customization and fine tuning options for some of these settings.

Setup Parameters

This window is restricted only to admin level (factory) users. End users and service level users can't modify the setup parameters.

6.2.1 Setup Parameters Section

6.2.1.1 Setup Parameters 1 Window



Fig. 60 Setup Parameters Menu Unit System Parameters Window

- 1 **SI (International System of Units) Button:** Switches the unit system to the "Metric Units".
- 2 **IU (Imperial Units) Button:** Switches the unit system to the "Imperial Units".
- 3 **Back Button:** Exits back to the "Parameters" menu.
- 4 **Home Button:** Exits back to the "Main" menu.
- 5 **Next Button:** Switches to the next window.

Table 45 Setup Parameters 1 Window Component List

6.2.1.2 Setup Parameters 2 Window

This function is only available on the TFI3516 and TFI3521 models.

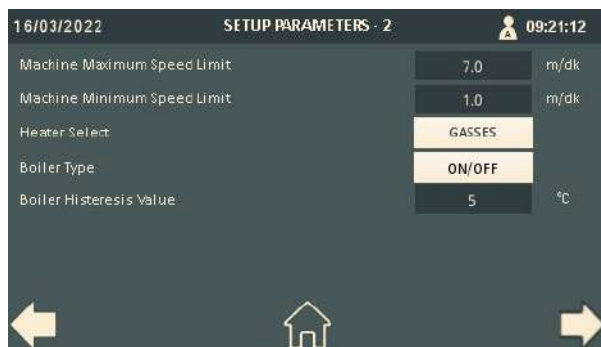

Fig. 61 Setup Parameters 2 Window

- 1 **Setup Parameters 2 List:** Displays the status of the Setup 2 parameters.
- 2 **Back Button:** Switches to the "Setup Parameters 1" window.
- 3 **Home Button:** Exits back to the "Main" menu.
- 4 **Next Button:** Switches to the "Setup Parameters 3" window.

Table 46 Setup Parameters 2 Window Component List

| |
|---|
| Machine Maximum Speed Limit Maximum allowed roller speed for ironing program. |
| Machine Minimum Speed Limit Minimum allowed roller speed for ironing program. |
| Heater Select It configures the heating type of the machine. (Gas / Electric) |

Table 47 Setup Parameters 2 Descriptions

6.2.1.3 Setup Parameters 3 Window

This function is only available on the TFI3516 and TFI3521 models.



Fig. 62 Setup Parameters 3 Window

- 1 **Setup Parameters 3 List:** Displays the status of the Setup 3 parameters.
- 2 **Back Button:** Switches to the "Setup Parameters 2" window.
- 3 **Home Button:** Exits back to the "Main" menu.

Table 48 Setup Parameters 3 Window Component List

| |
|---|
| Motor Frequency Motor plate information of the main roller electric motor. |
| Motor RPM Motor plate information of the main roller electric motor. |
| Gearbox Ratio |
| Number of Teeth of Motor Gear Number of teeth located on the main motor. This value is used to calculate the ironing speed. |
| Cylinder Diameter Diameter of the ironing cylinder. This value is used to calculate the ironing speed. |
| Number of Teeth of Cylinder Number of teeth on the ironing roller. This value is used to calculate the ironing speed. |
| Calculated Motor Frequency Calculated AC Drive output frequency of the main roller motor to achieve the set ironing speed during operation. |

Table 49 Setup Parameters 3 Descriptions

6.2.2 Burner Parameters Section
6.2.2.1 Temperature Sensors Window

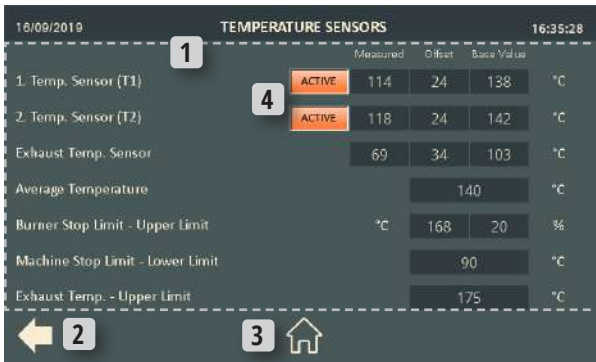

Fig. 63 Temperature Sensor Parameters Window on TFI3516/TFI3521 Models



Fig. 64 Temperature Sensor Parameters Window on TFI6026/TFI6032 Models

- 1 Temperatur Sensor Parameters List:** Displays the status of the temperature sensor parameters.
- 2 Back Button:** Exits back to the "Parameters" menu.
- 3 Home Button:** Exits back to the "Main" menu.
- 4 Active/Passive Buttons:** Activate/deactivate the temperature sensors.
- 5 Next Button:** Switches to the next window.

Table 50 Temperature Sensors Window Component List

- 1. Temp. Sensor (T1)**
- 2. Temp Sensor (T2)**
- 3. Temp Sensor (T3)**

The "Measured" cell displays the value which are being read from the temperature sensors.

The "Offset" cell sets the absolute value used to offset the reading value of the temperature sensors to the "Base Value". The "Base Value" cell displays the value which is used as the value displayed to the operator and used by the controller as the value of the temperature sensors.

The offset value can be set between the limits "-100" and "100".

The "Active/Passive" button is used to disable the temperature sensor in case the sensor gets damaged.

Exhaust Temp. Sensor

Average Temperature

Calculated average value from all active temperature sensors. This value cannot be changed. It's only displayed for informational purposes.

Burner Stop Limit - Upper Limit

Machine Stop Limit - Lower Limit

Target temperature value for main roller to cooldown and stop eventually. The heating system will be off but the ironer will keep on rotating until it cools down to the set value.

Exhaust Temp. - Upper Limit

Heating operation shut off temperature limit value based on exhaust temperature.

Table 51 Temperature Sensor Parameter Descriptions

6.2.2.2 Burner PID Parameters Window

This function is only available on the TFI3516 and TFI3521 models.

Never change any PID control parameters without consulting the manufacturer.

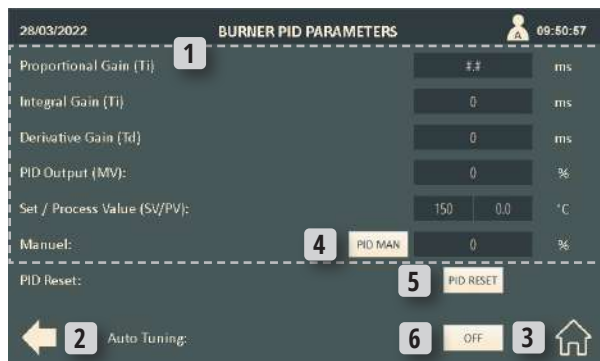

Fig. 65 Parameters Menu Burner PID Parameters Window on TFI6026/TFI6032 Models

- 1 **Burner PID Parameters List:** Displays the status of the burner PID parameters.
- 2 **Back Button:** Exits back to the "Temperature Sensors" window.
- 3 **Home Button:** Exits back to the "Main" menu.
- 4 **PID Manual Button:** Activates/deactivates the manual PID gain ratio.
- 5 **PID Reset Button:** Resets the PID parameters back to their factory settings.
- 6 **Auto Tuning On/Off Button:** Activates/deactivates the "Auto Tuning" function.

Table 52 Burner PID Parameters Window Component List

| |
|---|
| PID Reset Resets the PID values before the "Auto Tune" process. |
| Auto Tuning Automatically sets the PID parameters by conducting a test heating cycle. Never feed the ironer with linen during the testing process. |

Table 53 Burner PID Parameter Descriptions

6.2.3 Clutch Parameters Window

This function is only available on the TFI6026 and TFI6032 models.



Fig. 66 Parameters Menu Clutch Parameters Window

- 1 **Back Button:** Exits back to the "Parameters" menu.
- 2 **Home Button:** Exits back to the "Main" menu.

Table 54 Clutch Parameters Window Component List

This menu is utilized by the manufacturer to calibrate the clutch parameters and display them to the service level users.

| |
|--|
| Waiting Duration Before Clutch It displays and sets the waiting duration before the clutch operation. The duration value can be set between the limits "0" and "100". |
| Maximum Roller Speed It displays and sets the maximum speed limit of the roller during the calibration process. This parameter is restricted to "Admin" level users, so a "Service" level user can't modify them on site. |
| Minimum Roller Speed It displays and sets the minimum speed limit of the roller during the calibration process. This parameter is restricted to "Admin" level users, so a "Service" level user can't modify them on site. |
| Clutch Working Duration at Maximum Speed It displays and sets the working duration of the clutch at its maximum speed. This parameter is restricted to "Admin" level users, so a "Service" level user can't modify them on site. |
| Clutch Working Duration at Minimum Speed It displays and sets the working duration of the clutch at its minimum speed. This parameter is restricted to "Admin" level users, so a "Service" level user can't modify them on site. |
| Calculated Clutch Active Duration It displays the calculated working duration of the clutch. |

Table 55 Clutch Parameter Descriptions

6.2.4 Folding Parameters Section

6.2.4.1 Auto Fold Parameters Window

This function is only available on the TFI6026 and TFI6032 models.



Fig. 67 Parameters Menu Auto Fold Parameters Window

- 1 **Auto Fold Parameters List:** Displays the status of the auto fold parameters.
- 2 **Back Button:** Exits back to the "Parameters" menu.
- 3 **Home Button:** Exits back to the "Main" menu.
- 4 **Next Button:** Switches to the "Manuel Folder Parameters" window.

Table 56 Auto Fold Parameters Window Component List

| |
|---|
| <p>Value to be Subtracted from First Fold for Auto Mode It displays and sets the length value which is subtracted from the first fold reading of a program in "Auto Mode". The length value can be set between the limits "0" and "100".</p> |
| <p>Fold Length After First Fold It displays and sets the fold length value for the first fold reading of a program. The length value can be set between the limits "25" and "50".</p> |
| <p>Distance Between Input and Output Sensors It displays and sets the distance value between the input and output folding sensors. The distance value can be set between the limits "150" and "210".</p> |
| <p>Length of the Last Part of Folded Linen It displays and sets the length value of the last folded part of the linen. The length value can be set between the limits "10" and "50".</p> |

Table 57 Auto Fold Parameter Descriptions

6.2.4.2 Manual Folder Parameters Window

This function is only available on the TFI6026 and TFI6032 models.



Fig. 68 Parameters Menu Manuel Folder Parameters Window

- 1 **Manual Folder Parameters List:** Displays the status of the manual folder parameters.
- 2 **Back Button:** Switches to the "Auto Fold Parameters" window.
- 3 **Home Button:** Exits back to the "Main" menu.
- 4 **Next Button:** Switches to the "Cylinder Movement Correction Parameters" window.

Table 58 Manual Folder Parameters Window Component List

| |
|--|
| <p>Calculated Linen Length It displays the calculated linen length value of the current selected program.</p> |
| <p>Calculated First Fold Length It displays the calculated first fold length value of the current selected program.</p> |
| <p>Current Linen Length It displays the total length value of the currently processed linen. This value is used as an informational reference for the "Manual Folder Parameters".</p> |

Table 59 Manual Folder Parameter Descriptions

6.2.4.3 Cylinder Movement Correction Parameters Window

This function is only available on the TFI6026 and TFI6032 models.

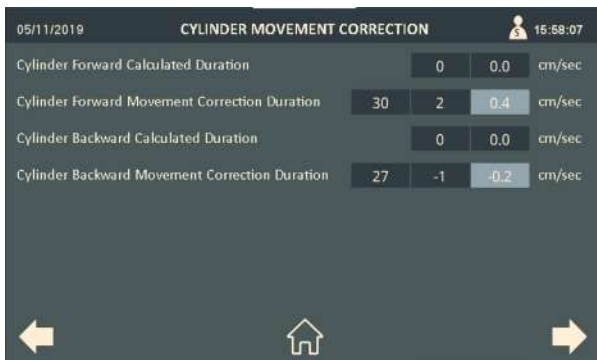

Fig. 69 Parameters Menu Cylinder Movement Correction Parameters Window

1 Cylinder Movement Correction Parameters

List: Displays the status of the cylinder movement correction parameters.

2 Back Button: Switches to the "Manual Folder Parameters" window.

3 Home Button: Exits back to the "Main" menu.

4 Next Button: Switches to the "Duration of Cylinder Movement Parameters" window.

Table 60 Cylinder Movement Correction Parameters Window Component List

| |
|--|
| <p>Cylinder Forward Calculated Duration It displays the calculated duration value of the cylinder forward action.</p> |
| <p>Cylinder Forward Movement Correction Duration It displays and sets the correctional duration value of the cylinder forward action.</p> |
| <p>Cylinder Backward Calculated Duration It displays the calculated duration value of the cylinder backward action.</p> |
| <p>Cylinder Backward Movement Correction Duration It displays and sets the correctional duration value of the cylinder backward action.</p> |

Table 61 Cylinder Movement Correction Parameter Descriptions

6.2.4.4 Duration of Cylinder Movement Parameters Window

This function is only available on the TFI6026 and TFI6032 models.

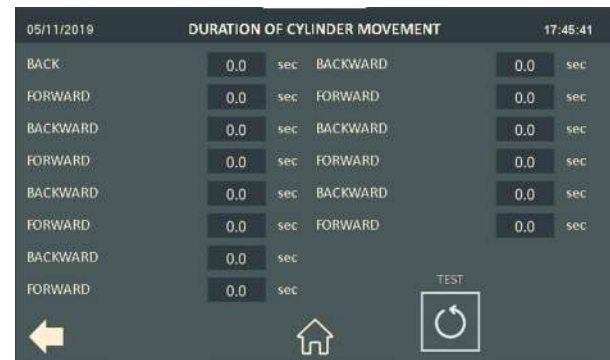

Fig. 70 Parameters Menu Duration of Cylinder Movement Parameters Window

1 Duration of Cylinder Movement Parameters

List: Displays the status of the cylinder movement correction parameters.

2 Back Button: Switches to the "Cylinder Movement Correction Parameters" window.

3 Home Button: Exits back to the "Main" menu.

4 Test Button: Activates the cylinder for a test run.

Table 62 Duration of Cylinder Movement Parameters Window Component List

| |
|--|
| <p>Backward It displays the duration of the cylinder backward movement.</p> |
| <p>Forward It displays the duration of the cylinder forward movement.</p> |

Table 63 Duration of Cylinder Movement Parameter Descriptions

6.3 MANUEL CONTROL WINDOW



Fig. 71 Manuel Control Window on TFI6026/TFI6032 models



Fig. 72 Manuel Control Window on TFI3516/TFI3521 models

- 11 **Back Rotation Button:** It moves the folding arm backward.
- 12 **Back Button:** Switches to the "Service" menu.
- 13 **Home Button:** Exits back to the "Main" menu.

Table 64 Manuel Control Window Component List

- 1 **Manuel Control Window Icon:** It indicates that the manuel control functions are active.
- 2 **Backward Movement Button:** It moves the cylinder in the backward direction.
- 3 **Forward Movement Button:** It moves the cylinder in the forward direction.
- 4 **Clutch Button:** It activates the clutch or the gearbox that rotates the exit belts of the folding table.
- 5 **Fan Motor Button:** It manually activates the exhaust fan.
- 6 **Light 1 Button:** It activates "Light 1" which is located on top of the feeding belts.
- 7 **Light 2 Button:** It activates "Light 2" which is located on top of the feeding belts.
- 8 **Light 3 Button:** It activates "Light 3" which is located on top of the feeding belts.
- 9 **Front Rotation Button:** It moves the folding arm forward.
- 10 **Test Button:** It continuously moves the folding arm back and forward. This function is mostly used to adjust the folding arm movement on pneumatic models.

SYSTEM ALARMS

| Alarm Name | Alarm Explanation |
|----------------------------------|--|
| Emergency Stop Button Alarm | Emergency Stop Alarm |
| Hand Protection Switch Activated | Hand Protection Switch Alarm |
| Vaccum Fault | Indicates that the exhaust outlet is blocked |
| Exhaust Fan Thermic Fault | Indicates that exhaust fan thermic switch has sensed high temperature. |
| Burner Fault | Indicates that a burner alarm is present. |
| AC Drive Fault | Indicates that an AC drive (speed control failure) alarm is present. |
| T1 Sensor Temp. Fault | Indicates that the T1 temperature sensor is reading out of limit values. |
| T2 Sensor Temp. Fault | Indicates that the T2 temperature sensor is reading out of limit values. |
| T3 Sensor Temp. Fault | Indicates that the T3 temperature sensor is reading out of limit values. |
| High Temperature Fault | Indicates that the thermostat switch has sensed high temperature. |
| Exhaust Temp. Sensor Fault | Exhaust Temp. sensor error |
| Exhaust Temp. Too High! | Indicates that the exhaust temperature has raised over ...°C (...°F) |

Table 65 System Alarms List

NOTES

Notes 1: Burner Parameters List

| No | Parameter Description | Unit | Factory Default | Min Value | Max Value |
|----|--|------|--------------------|-----------|-----------|
| 1 | Temperature Sensor (T1) Offset Value | °C | Set by the factory | -100 | 100 |
| 2 | Temperature Sensor (T2) Offset Value | °C | Set by the factory | -100 | 100 |
| 3 | Exhaust Temperature Sensor Offset Value | °C | Set by the factory | -100 | 100 |
| 4 | Burner Stop Limit - Upper Limit Base Value (%) | °C | 20 | 0 | 25 |
| 5 | Machine Stop Limit - Lower Limit | °C | 90 | 30 | 100 |
| 6 | Exhaust Temperature - Upper Limit | °C | 175 | 100 | 200 |

Table 66 Burner Parameters List

Notes 2: Clutch Parameters List

| No | Parameter Description | Unit | Factory Default | Min Value | Max Value |
|----|---------------------------------|------|-----------------|-----------|-----------|
| 1 | Waiting Duration Before Clutch | sec | 2 | 0 | 100 |
| 2 | Maximum Clutch Working Duration | sec | 6 | 0 | 100 |
| 3 | Minimum Clutch Working Duration | sec | 1.6 | 0 | 100 |

Table 67 Clutch Parameters List

Notes 3: Folding Parameters List

| No | Parameter Description | Unit | Factory Default | Min Value | Max Value |
|----|--|--------|--------------------|-----------|-----------|
| 1 | Cylinder Forward Movement Correction Duration | cm/sec | Set by the factory | -1 | 1 |
| 2 | Cylinder Backward Movement Correction Duration | cm/sec | Set by the factory | -10 | 10 |

Table 68 Folding Parameters List

Notes 4: Digital and Analog I/O Lists

| DIGITAL OUTPUT MODULE 1 | | |
|-------------------------|------------|-------------------------|
| No | Connection | Explanation |
| 1 | Y0 | Cylinder Motor Forward |
| 2 | Y1 | Cylinder Motor Backward |
| 3 | Y2 | Burner Reset |
| 4 | Y3 | Clutch |
| 5 | Y4 | Burner Start |
| 6 | Y5 | Fan Start |

| DIGITAL OUTPUT MODULE 2 | | |
|-------------------------|------------|--------------|
| No | Connection | Explanation |
| 1 | Y0 | Folding Rear |
| 2 | Y1 | FoldingFront |
| 3 | Y2 | LED 1 |
| 4 | Y3 | LED 2 |
| 5 | Y4 | LED 3 |

| THERMO MODULE | | |
|---------------|------------|----------------|
| No | Connection | Explanation |
| 1 | CH1 | Thermocouple 1 |
| 1 | CH2 | Thermocouple 2 |
| | CH4 | Thermocouple 3 |

| ANALOG OUTPUT MODULE | | |
|----------------------|------------|-------------------------------------|
| No | Connection | Explanation |
| 1 | I5+ | Burner Analog Positive (+) Terminal |
| 1 | COM | Burner Analog Negative (-) Terminal |

| DIGITAL INPUT MODULE 1 | | |
|------------------------|------------|----------------------|
| No | Connection | Explanation |
| 1 | X0 | Emergency Stop Input |
| 2 | X1 | Reserved |
| 3 | X2 | Length Sensor 1 |
| 4 | X3 | Reserved |
| 5 | X4 | Length Sensor 2 |
| 6 | X5 | Reserved |
| 7 | X6 | Safety Switch 1 |
| 8 | X7 | Folding Rear Switch |

| DIGITAL INPUT MODULE 2 | | |
|------------------------|------------|----------------------|
| No | Connection | Explanation |
| 1 | X0 | Folding Front Switch |
| 2 | X1 | Vacuum |
| 3 | X2 | Fan Thermal Fault |
| 4 | X3 | Burner Fault |
| 5 | X4 | Burner On |
| 6 | X5 | High Temperature |
| 7 | X6 | AC Drive Fault |
| 8 | X7 | Safety Switch 2 |

Table 69 TFI6026/TFI6032 Digital and Analog I/O Lists



To avoid the risk of being caught up in the machine's moving parts it is essential to :

- Follow the legislation and regulations for health and safety in the workplace in force in the country where the machine has been installed.
- Suitable fitted clothing to be worn. (TS10472-5 / 5.4.3)
- Scarves, ties, neckerchiefs, loose garments, open cardigans, hanging belts, wide sleeves, etc. must not be worn.
- Wear some type of hair clip.
- Avoid wearing jewelry or accessories on the hands, arms, neck, etc.
- Do not use the machine without all the cover and safety guards correctly placed.
- Disconnect the power supply and close off the sources of heating valves before removing any form of protection. (TS10472-5 / 5.4.4)



The linen are at a high temperatures when they emerge from the ironer. Protect your hands with heat-insulated gloves.

PERSONAL PROTECTION WEAR

The machine stops in the case of a sudden loss of the power supply. Once the power supply has been reconnected, the "Startup Screen" and the "Hand Protection Guard Check Step" will be displayed consecutively.

PROTECTION AGAINST BURNT LINEN AND IRONING STRAPS

In the event of an unexpected shutdown of the machine, and in order to prevent deterioration of the linen at that time in contact with the cylinder or ironing straps, the ironer is equipped with a crank handle that allows the cylinder to be rotated manually.



Photo 3 Crank Handle and its Hanger

Once the items of linen in contact with the cylinder have been extracted, if the cylinder temperature is very high, a wet sheet should be passed through the whole cylinder by operating the handle, in order to protect the ironing straps. The handle is delivered in the scope of delivery.

The handle is located at the rear of the ironer.

UNEXPECTED INTERRUPTION OF THE POWER SUPPLY

USAGE OF THE CRANK HANDLE ON THE 60XX SERIES

- Turn off the automatic external switch.
- Insert the helical end of the crank handle through the opening in the right-hand side cover of the machine and insert it into the end of the internal shaft.
- Turn the handle. The handle only allows rotation. The cylinder will rotate in the reverse direction to the ironing direction, and the ironing straps will move towards the outside of the ironer.
- **VERY IMPORTANT!** Before resuming operation of the machine, remove the crank handle and store it in its hanger at the rear of the machine (Photo 4).



Photo 4 Crank Handle Usage on the 60xx series

Handle Decoupling

The cylinder rotation crank handle is equipped with a helical end, causing it to decouple from the shaft should the machine start up unexpectedly, thereby avoiding possible accidents.

USAGE OF A RING SPANNER ON THE 35XX SERIES

- Turn off the automatic external switch.
- Place a ring spanner onto the nut centered on the green colored "Manual Driving Hole" located at the right rear side of the machine.

UNEXPECTED INTERRUPTION OF THE POWER SUPPLY

- Rotate the ring spanner clockwise to rotate the main roll through the gearbox. Refer to Photo 5.



Photo 5 Ring Spanner Usage on the 35xx series

PROLONGED STOPPAGES

In the case of the machine being out of use for a prolonged length of time and to avoid corrosion of the cylinder surface, we recommend to place a piece, folded in half and impregnated with paraffin, inside the machine numerous times. This operation must be carried out when the ironer is at a suitable temperature (minimum of 130°C, 260°F) to allow for the paraffin to liquefy.

FREING A TRAPPED PERSON

The ironer's linen feeder is designed to prevent access to the ironing rollers. For safe use of the ironer it is essential to make sure the safety guards are working properly. (TS10472-5 / 5.2.2.6)

For this reason :

- Never start the machine up or use it until all the covers have been replaced and properly locked.
- Check the hand protection device on a daily basis.
- Use the personal protection equipment. Please refer to "Personal Protection Wear" section for the details.

RECOVERY PROCEDURE TO FOLLOW IN THE EVENT OF AN ENTRAPMENT

- Press the emergency stop button.
- Disconnect the switch breaker from the machine's power supply.
- Hold the manual crank handle by the red area and insert the opposite end through the opening in the top left-hand side cover of the machine and insert it into the end of the internal shaft.
- Turn the handle. The cylinder will rotate in the reverse direction to the ironing direction, and the ironing straps will move towards the outside of the ironer.

MAINTENANCE AND SERVICE

SECURITY INFORMATION

The daily maintenance and cleaning activities for the product can be done by the operator or the technician.

The periodical maintenances must be done by authorized and licensed personnel.

During the maintenance the power switch must be on "0" position and be locked. The maintenance may start at least in 5 minutes after the switch is positioned to "0". This practice is necessary to completely discharge all the capacitors.

Check that all moving parts of the machine are stopped or are at rest.

After completing the maintenance procedures the product must be handed over to the machine operator with an official report.

It is recommended to properly fill the registration form related to the maintenance procedures.

The conditions mentioned in the SAFETY INFORMATION section must be provided on all maintenance procedures.

END OF SHIFT INSTRUCTIONS

- Turn off electricity after the ironer roller has cooled down.
- Turn off the air valves.

DAILY MAINTENANCE

- The external body of the product must be cleaned with a damp cloth.

WEEKLY MAINTENANCE

The daily maintenance must be repeated.

- The energy cable of the product must be checked for tearing, snapping, or fissuring.
- The impellers of the engine cooler fan must be cleaned and checked for cracking or fissuring.
- Bearings should be checked acoustically by starting the machine and running it at idle. Defective bearings should be changed immediately.
- The noise level of the roller bearings must be checked.
- The electric box must be cleaned with dry air or a vacuum cleaner after main electrical supply is turned off.
- For machines with pneumatic systems the air hoses must be checked, the water in the conditioners must be discharged, and if the oil level is low, oil must be added.

MONTHLY MAINTENANCE

Daily and weekly maintenances must be repeated.

- The valves on the machine must be checked for leakage and their functions.
- The engine's current values must be checked with an ammeter to ensure that they don't exceed the specified values.
- Limit switches must be checked for their functions.
- Security systems which contain switches like loading door switch, filter door switch etc must be checked manually.

QUARTERLY MAINTENANCE

- All the drum drive shaft and idler shaft bearings must be lubricated every three (3) months. Use a Shell Gadus C100 grease. Lubrication is mandatory and if not performed premature bearing failure will occur.

MAINTENANCE AND SERVICE

DEHUMIDIFIER MAINTENANCE

Dehumidifiers are installed into the air utility lines on models which have pneumatic components. Air compressors create water and oil which is transmitted into the machine via the air utility lines. Pneumatic valves and cylinders are prone to failure because of the water and oil in the air utility lines. Pneumatic component failures caused by excess water and oil won't be covered by warranty.



Photo 6 Dehumidifier

| | |
|---|----------------------|
| 1 | Oil and Water Filter |
| 2 | Lubricator |
| 3 | Drain Button |

The air regulator on the machine does consist of 2 tubes. One is used for lubrication and the other one is used to filter and capture excess liquids in the air utility lines.

The first tube which is installed next to the air inlet does filter the oil and water in the air. This tube should be visually checked once every week. If water and oil is accumulated in the tube then press the button on its bottom and push the button upwards and completely drain the liquid in the tube into a container. If this tube is being filled frequently then check the dehumidifier for problems. If the water capture cup is contaminated with oil then check your compressor for oil

leaks. Shut off the air supply to the machine if you spot oil in the compressor in order to save the pneumatic system from hazards and call the service.

The second tube next to the first tube contains oil which lubricates the pneumatic valves and cylinders for a smoother operation. The oil level in the second tube should be checked once every 6 months. The tube should be filled with Shell Tellus C10 branded oil if the oil level is decreased. The oil should be fully consumed once every 6 months. If the oil is not decreasing at a 6 months period then rotate the oiling setting screw on the tube clockwise via a screwdriver to let more oil to flow into the pneumatic system.

CALLING A SERVICE

It is essential for you to give sufficient and accurate information for the authorized technical service to treat with the right equipment and solve the problem. The costs and time loss caused by additional servicing time can be prevented.



Take note of the machine's serial code, the inventory code of the required spare part and the label if possible before calling the service.

Take note of the defect of the machine, the steps of occurrence and the consequences.

Notify these situations in detail in your description with the authorized service.

ENVIRONMENTAL

DISPOSAL OF UNIT

This symbol on the product or on its packaging indicates that this product shall not be treated as household waste. Refer to Figure 70. Instead it shall be handed over to the applicable collection point for the recycling of electrical and electronic equipment. Ensuring this product is disposed of correctly will help prevent potential negative consequences for the environment and human health which could otherwise be caused by inappropriate waste handling of this product. The recycling of materials will help to conserve natural resources. For more detailed information about recycling of this product, please contact the local city office, household waste disposal service, or the source from which the product was purchased.

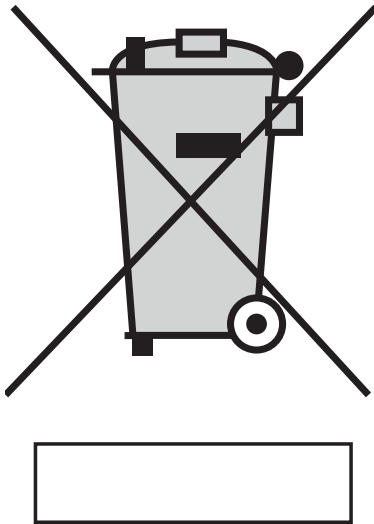

Fig. 73 "Not Household Waste" Symbol

INDEX

FIGURE INDEX

| | | | |
|---|----|---|----|
| Fig. 1 Front, rear, right and left side view diagrams of TFI6026 / TFI6032 standard models | 11 | | |
| Fig. 2 Front, rear, right and left side view diagrams of TFI6026 / TFI6032 rear exit models | 12 | | |
| Fig. 3 Front, rear, right, left, and top side view diagrams of TFI3516 / TFI3521 standard models | 13 | | |
| Fig. 4 Emergency Stop Button Locations on TFI6026/TFI6032 models | 16 | | |
| Fig. 5 Emergency Stop Button Locations on TFI3516/TFI3521 models | 17 | | |
| Fig. 6 Exhaust Duct Elbow Angle Warnings | 19 | | |
| Fig. 7 Prohibited Signs | 21 | | |
| Fig. 8 Safety Critical Signs | 21 | | |
| Fig. 9 Hazard Signs | 21 | | |
| Fig. 10 Label Text Sections | 22 | | |
| Fig. 11 TFI6026 and TFI6032 Label Locations | 23 | | |
| Fig. 12 TFI3516 and TFI3521 Label Locations | 24 | | |
| Fig. 13 Location of the Serial Plate | 29 | | |
| Fig. 14 Forklift Lift Points | 30 | | |
| Fig. 15 Forklift Center of Gravity Warning | 30 | | |
| Fig. 16 Forklift Side Lifting Warning | 30 | | |
| Fig. 17 Pallet Truck Lifting Points | 31 | | |
| Fig. 18 Top Views for Installation Clearances on standard TFI3516, TFI3521, TFI6026 and TFI6032 models | 34 | | |
| Fig. 19 Top Views for Installation Clearances on rear exit TFI6026 and TFI6032 models | 35 | | |
| Fig. 20 Ventilation Openings for Electric Heated Models | 37 | | |
| Fig. 21 Ventilation Openings for Gas Heated Models | 38 | | |
| Fig. 22 Correct and False Feet Adjustment for Product Leveling | 39 | | |
| Fig. 23 Feet Adjustment for the Flatwork Ironer Models | 39 | | |
| Fig. 24 Earth Connection Sticker | 42 | | |
| Fig. 25 Steam Sticker | 44 | | |
| Fig. 26 Steam Condensate Sticker | 44 | | |
| Fig. 27 Main Steam Line Condense Point and Elevation Diagram | 45 | | |
| Fig. 28 Flatwork Ironer Condenser Connection Detail | 45 | | |
| Fig. 29 Flatwork Ironer Steam Connection Detail | 45 | | |
| Fig. 30 TFI Controller Startup Screen | 49 | | |
| Fig. 31 TFI Hand Protection Guard Check Screen | 49 | | |
| Fig. 32 Main Menu Window | 50 | | |
| Fig. 33 Language Selection Menu | 52 | | |
| Fig. 34 Quick Start Button / Program Execution Window on TFI6026 and TFI6032 models | 53 | | |
| Fig. 35 Quick Start Button / Program Execution Window on TFI3516 and TFI3521 models | 54 | | |
| Fig. 36 Virtual Keyboard for Program Name Entry | 55 | | |
| Fig. 37 Virtual Keyboard for Ironing Speed Entry | 55 | | |
| Fig. 38 Virtual Keyboard for Roller Temperature Value Entry | 56 | | |
| Fig. 39 Folding Mode Selection Window | 56 | | |
| Fig. 40 Folding Length Value Entry | 57 | | |
| Fig. 41 Folding Length Value Approval Window | 57 | | |
| Fig. 42 Folding Count Entry Screen | 57 | | |
| Fig. 43 Linen-Fold Length Graph for Automatic Mode | 58 | | |
| Fig. 44 Linen-Fold Length Graph for Semi Automatic Mode | 58 | | |
| Fig. 45 Linen-Fold Length Graph for Manual Mode | 59 | | |
| Fig. 46 The retractable tray warning message | 60 | | |
| Fig. 47 Program Save Confirmation Dialog Box | 60 | | |
| Fig. 48 Program Selection Menu | 61 | | |
| Fig. 49 Alarm List Menu | 62 | | |
| Fig. 50 Brightness and Date/Time Settings Menu | 62 | | |
| Fig. 51 Brightness Setting Window | 62 | | |
| Fig. 52 Date/Time Setting Window | 63 | | |
| Fig. 53 Service Menu | 63 | | |
| Fig. 54 I/O Link Menu Digital Inputs Window on TFI6026/TFI6032 models | 64 | | |
| Fig. 55 I/O Link Menu Digital Inputs Window on TFI3516/TFI3521 models | 64 | | |
| Fig. 56 I/O Link Menu Digital Outputs Window on TFI6026/TFI6032 models | 65 | | |
| | | Fig. 57 I/O Link Menu Digital Outputs Window on TFI3516/TFI3521 models | 65 |
| | | Fig. 58 Parameters Menu on TFI6026/TFI6032 models | 66 |
| | | Fig. 59 Parameters Menu on TFI3516/TFI3521 models | 66 |
| | | Fig. 60 Setup Parameters Menu Unit System Parameters Window | 66 |
| | | Fig. 61 Setup Parameters 2 Window | 67 |
| | | Fig. 62 Setup Parameters 3 Window | 67 |
| | | Fig. 63 Temperature Sensor Parameters Window on TFI3516/TFI3521 Models | 68 |
| | | Fig. 64 Temperature Sensor Parameters Window on TFI6026/TFI6032 Models | 68 |
| | | Fig. 65 Parameters Menu Burner PID Parameters Window on TFI6026/TFI6032 Models | 69 |
| | | Fig. 66 Parameters Menu Clutch Parameters Window | 70 |
| | | Fig. 67 Parameters Menu Auto Fold Parameters Window | 71 |
| | | Fig. 68 Parameters Menu Manuel Folder Parameters Window | 71 |
| | | Fig. 69 Parameters Menu Cylinder Movement Correction Parameters Window | 72 |
| | | Fig. 70 Parameters Menu Duration of Cylinder Movement Parameters Window | 72 |
| | | Fig. 71 Manuel Control Window on TFI6026/TFI6032 models | 73 |
| | | Fig. 72 Manuel Control Window on TFI3516/TFI3521 models | 73 |
| | | Fig. 73 "Not Household Waste" Symbol | 85 |

TABLE INDEX

| | |
|--|----|
| Table 1 Components of the front, rear, right and left side view diagrams of TFI6026 / TFI6032 standard models | 11 |
| Table 2 Length values for TFI6026 / TFI6032 standard model diagrams | 11 |
| Table 3 Components of the front, rear, right and left side view diagrams of TFI6026 / TFI6032 rear exit models | 12 |
| Table 4 Length values for TFI6026 / TFI6032 rear exit model diagrams | 12 |
| Table 5 Components of the front, rear, right, left, and top side view diagrams of TFI3516 / TFI3521 standard models | 13 |
| Table 6 Length values for TFI3516 / TFI3521 standard model diagrams | 13 |
| Table 7 Precautionary Statement Icons and Explanations | 16 |
| Table 8 Label Codes and Names for the TFI 60xx Models | 23 |
| Table 9 Label Codes and Names for the TFI 35xx Models | 24 |
| Table 10 Handling and Transportation Labels | 25 |
| Table 11 Environmental Conditions | 33 |
| Table 12 Ducting Measuring Points | 40 |
| Table 13 Exhaust Ducting Technical Datasheet for TFI60xx series | 41 |
| Table 14 Exhaust Ducting Technical Datasheet for TFI35xx series | 41 |
| Table 15 Cable and Fuse Values for 240V Three-Phase Voltage | 42 |
| Table 16 Cable and Fuse Values for 380V Three-Phase Voltage | 42 |
| Table 17 Cable and Fuse Values for 480V Three-Phase Voltage | 42 |
| Table 18 Cable and Fuse Values for 240V Three-Phase Voltage | 43 |
| Table 19 Cable and Fuse Values for 380V Three-Phase Voltage | 43 |
| Table 20 Cable and Fuse Values for 480V Three-Phase Voltage | 43 |
| Table 21 Flatwork Ironer Condenser Connection Diagram Component List | 45 |
| Table 22 Flatwork Ironer Steam Connection Diagram Component List | 45 |
| Table 23 Required Measuring Devices for Initial Start-Up | 47 |
| Table 24 Main Menu Content List | 50 |
| Table 25 Button States | 51 |
| Table 26 Burner Icon States | 51 |
| Table 27 Language Selection Menu Content List | 52 |
| Table 28 Program Execution Window Component List | 53 |
| Table 29 Program Execution Window Component List | 54 |
| Table 30 Linen-Fold Length Table for Automatic Mode | 58 |
| Table 31 Linen-Fold Length Table for Semi Automatic Mode | 58 |
| Table 32 Linen-Fold Length Table for Manual Mode | 59 |
| Table 33 Program Selection Menu Component List | 61 |
| Table 34 Alarm List Menu Component List | 62 |
| Table 35 Brightness and Date/Time Menu Component List | 62 |
| Table 36 Brightness Setting Window Component List | 62 |
| Table 37 Date/Time Setting Window Component List | 63 |
| Table 38 Service Menu Component List | 63 |
| Table 39 Digital Inputs Window Component List | 64 |
| Table 40 Digital Input Descriptions | 64 |
| Table 41 Temperature Sensor Descriptions | 64 |
| Table 42 Digital Outputs Window Component List | 65 |
| Table 43 Digital Output Descriptions | 65 |
| Table 44 Parameters Menu Component List | 66 |
| Table 45 Setup Parameters 1 Window Component List | 66 |
| Table 46 Setup Parameters 2 Window Component List | 67 |
| Table 47 Setup Parameters 2 Descriptions | 67 |
| Table 48 Setup Parameters 3 Window Component List | 67 |

| | |
|--|----|
| Table 49 Setup Parameters 3 Descriptions | 67 |
| Table 50 Temperature Sensors Window Component List | 68 |
| Table 51 Temperature Sensor Parameter Descriptions | 69 |
| Table 52 Burner PID Parameters Window Component List | 69 |
| Table 53 Burner PID Parameter Descriptions | 70 |
| Table 54 Clutch Parameters Window Component List | 70 |
| Table 55 Clutch Parameter Descriptions | 70 |
| Table 56 Auto Fold Parameters Window Component List | 71 |
| Table 57 Auto Fold Parameter Descriptions | 71 |
| Table 58 Manual Folder Parameters Window Component List | 71 |
| Table 59 Manual Folder Parameter Descriptions | 71 |
| Table 60 Cylinder Movement Correction Parameters Window Component List | 72 |
| Table 61 Cylinder Movement Correction Parameter Descriptions | 72 |
| Table 62 Duration of Cylinder Movement Parameters Window Component List | 72 |
| Table 63 Duration of Cylinder Movement Parameter Descriptions | 72 |
| Table 64 Manual Control Window Component List | 73 |
| Table 65 System Alarms List | 74 |
| Table 66 Burner Parameters List | 75 |
| Table 67 Clutch Parameters List | 76 |
| Table 68 Folding Parameters List | 77 |
| Table 69 TFI6026/TFI6032 Digital and Analog I/O Lists | 78 |

PHOTO INDEX

| | |
|--|----|
| Photo 1 Ducting Measuring Points | 41 |
| Photo 2 Analysis of Combustion Gases | 48 |
| Photo 3 Crank Handle and its Hanger | 80 |
| Photo 4 Crank Handle Usage on the 60xx series | 81 |
| Photo 5 Ring Spanner Usage on the 35xx series | 81 |
| Photo 6 Dehumidifier | 84 |

