

USER MANUAL

en

A300

FCS4070

Original operating instructions • 20164994 • 01 • 6/5/2020



Read the user manual before working on the machine.

Keep the manual with the machine and pass the manual along to the next user if the machine is sold or transferred to a third party.

FRANKE

TABLE OF CONTENTS

1	For your safety	5
1.1	Intended use	5
1.2	Prerequisites for using the coffee machine.....	5
1.3	Explanation of safety instructions according to ANSI.....	6
1.4	Safety concerns when using the coffee machine	6
2	Explanation of symbols	10
2.1	Symbols used in the manual	10
2.2	Symbols used in the software	11
3	Scope of delivery.....	15
4	Identification	16
4.1	Position of type plates	16
4.2	Type codes.....	16
5	Description of machine.....	18
5.1	Coffee machine	18
5.2	Add-on units.....	19
5.3	User interface.....	20
5.4	Quick Select operating mode.....	20
6	Installation	21
6.1	Preparations.....	21
6.2	Dimensions of the A300	22
6.3	Requirements of the water supply	23
6.4	Setting up and preparing the coffee machine	25
6.5	Connect the water supply	26
6.6	Connecting the wastewater	26
6.7	Connecting electrical circuit	27
6.8	Switching the machine on.....	28
7	Switching on the machine for the first time	29
7.1	Inserting a descaling cartridge	30
7.2	Refilling containers with resources.....	30
8	Configuration.....	31
8.1	Call up the maintenance level	31
8.2	PIN codes.....	31
8.3	My settings	31
9	Filling and emptying.....	37
9.1	filling the machine	37
9.2	Using and storing roasted coffee beans	37
9.3	Filling beans.....	38

9.4	Setting the grind coarseness	38
9.5	Filling powder	39
9.6	Filling the water tank	39
9.7	Filling milk	40
9.8	Emptying the grounds container.....	42
9.9	Empty the powder hopper.....	42
9.10	Emptying the cooling unit	43
10	Preparing drinks	45
10.1	Dispensing drinks with Quick Select	45
11	Cleaning.....	46
11.1	Introduction.....	46
11.2	Starting the cleaning process.....	46
11.3	Cleaning weekly	47
11.4	Rinsing coffee machine.....	50
11.5	Care kit	51
12	Descaling	53
12.1	Descaling repeat interval	53
12.2	Descalate.....	53
13	Troubleshooting.....	55
13.1	Error messages	55
13.2	Troubleshooting on the coffee machine.....	55
13.3	Help with problems concerning product quality	57
14	Technical data.....	59
14.1	Capacities in accordance with DIN 18873-2:2016-02	59
14.2	Technical data of the coffee machine.....	59
14.3	Coffee machine electrical connections.....	59
	Index.....	60

1 FOR YOUR SAFETY

1.1 Intended use

1.1.1 Coffee machine

- The A300 is a commercial machine for preparing drinks and is intended for use in food services, offices and other similar environments.
- The A300 is designed to process whole coffee beans, powder suitable for automatic devices and fresh milk.
- The A300 is intended for the preparation of drinks in accordance with these instructions and the technical data.
- The A300 is intended for operation indoors.

Please note

- The A300 is not suitable for use outdoors.

1.1.2 Add-on units

Cooling unit

- The cooling unit is used exclusively to keep milk cool while preparing coffee drinks with a coffee machine. Only use pre-cooled milk (2–5 °C or 36–41 °F).
- Only use Franke milk system cleaning agent.

Please note

- Other cleaning agents may leave residue in the milk system.

1.2 Prerequisites for using the coffee machine

- The A300 is intended for use by trained personnel.
- Each operator of the A300 must have read and understood the manual. This does not apply to its use in the self-service sector.
- Self-service machines must always be monitored to protect the users.
- Do not operate the A300 or add-on units until you have completely read and understood this manual.
- Do not use the A300 or add-on units if you are not familiar with the various functions.
- Do not use the A300 if the connection lines of the A300 or the add-on units are damaged.
- Do not use the A300 unless the A300 or the add-on units have been cleaned or filled as intended.
- Children under the age of 8 are not permitted to use the A300 and the add-on units.
- Children or persons with reduced physical, sensory, or mental capabilities must not use the A300 and the add-on units except under supervision, nor should they be permitted to play with the A300 and the add-on units.
- Children are not permitted to clean the A300 and the add-on units.

1.3 Explanation of safety instructions according to ANSI

Observation of these safety instructions is imperative to ensure personal safety and the protection of material goods.

Symbol and signal word indicate the severity of the hazard.



WARNING

WARNING indicates a potential danger. DANGER indicates an imminent danger which, if not avoided, will result in death or serious injury.



CAUTION

CAUTION indicates a hazardous situation which, if not avoided, could result in minor or moderate injury.



NOTICE

NOTICE directs your attention to the risk of damage to machinery.

1.4 Safety concerns when using the coffee machine



WARNING

Risk of fire

If the power cord is electrically overloaded, the heat generated can cause a fire.

- a) Never use power outlet strips, multi-sockets or extension cords to connect the coffee machine to the power supply.



WARNING

Risk of fatal injury from electrocution

Damaged power cords, lines or plug connections can lead to electrocution.

- a) Do not connect any damaged power cords, lines or plug connections to the power supply.
- b) Replace damaged power cables, lines or plug connections.
If the power cord is permanently attached, contact the service technician. If the power cord is not permanently attached, order and use a new, original power cord.
- c) Ensure that the machine and the power cord are not near any hot surfaces such as gas or electric stoves or ovens.
- d) Ensure that the power cord is not pinched and does not chafe on sharp edges.

**WARNING****Risk of fatal injury from electrocution**

Liquid/moisture entering the machine or leaks can lead to electrocution.

- a) Never point a liquid or steam jet at the machine.
- b) Do not pour any liquids on the machine.
- c) Do not immerse the machine in liquid.
- d) Disconnect the machine from the power supply in the event of a leak or if liquid/moisture enters the machine.

**WARNING****Risk of fatal injury from electrocution**

Work, repairs or servicing improperly performed on electrical systems can lead to electrocution.

- a) Have repairs on electrical parts carried out by service technicians using original spare parts.
- b) Have servicing work carried out by authorized persons with corresponding qualifications only.

**WARNING****Danger of suffocation**

Plastic packaging materials could cause children to suffocate.

- a) Ensure that children have no access to plastic packaging materials.

**WARNING****Risk of scalding**

Hot water is released during rinsing.

- a) Keep hands away from the spouts and nozzles during this process.
- b) Do not place anything on the drip grid.
- c) IN CASE OF SCALDING: Immediately cool the affected area and, depending on the severity of the injury, consult a doctor.

**WARNING****Risk of scalding**

Hot drinks can lead to scalding.

- a) Always be careful with hot drinks.
- b) Use only suitable drinking vessels.

**WARNING****Risk of scalding**

Hot liquids and steam escape during cleaning and can lead to scalding.

- a) Keep hands away from the spouts and nozzles during this process.

**WARNING****Risk of injury**

If objects find their way into the bean hopper or grinder, splinters may be ejected, leading to injury.

- a) Never insert any objects into the bean hopper or grinder.

**CAUTION****Cutting injuries/crushing**

The powder hopper's feeding mechanism can cause cuts or crushing injuries.

- a) Exercise care when cleaning the powder hopper.

**CAUTION****Irritation from cleaners**

Cleaning tablets, milk system cleaning agent, and descaler can lead to irritations of the skin or eyes.

- a) Observe the hazard warnings on the label of the respective cleaner.
- b) Avoid contact with your eyes and skin.
- c) Wash your hands after coming into contact with cleaning supplies.
- d) Cleaners must not find their way into drinks.

**CAUTION****Health hazard due to germ formation**

Inadequate cleaning can result in food residues accumulating in the machine and at the outlets, thereby contaminating products.

- a) Do not use the machine unless it has been cleaned according to the instructions.
- b) Clean the machine daily in accordance with the instructions.
- c) Inform operating personnel of the necessary cleaning measures.

**CAUTION****Health hazard due to germ formation**

If the machine is not used for extended periods, residue may accumulate.

- a) Clean the machine if it is not used for extended periods (more than 2 days).



CAUTION

Formation of mold

Mold can form on the coffee grounds.

- a) Empty and clean the grounds container at least once a day.



NOTICE

Machine damage caused by limescale build-up

If the water hardness is set incorrectly, limescale can build up in the coffee machine. Limescale deposits may damage the coffee machine.

- a) Measure the water hardness during commissioning. Then set the measured water hardness in the menu Commissioning. *Determining the water hardness with a measuring strip* [▶ 24].









To descale the machine, only use the descaler concentrate from Franke (item number 560.0589.837). This guarantees reliable descaling results.

- a) Make sure that you order descaler concentrate in good time so that you can descale the coffee machine immediately when the prompt appears on the coffee machine operator panel.

2 EXPLANATION OF SYMBOLS

2.1 Symbols used in the manual

2.1.1 Orientation

Symbol	Description
	Clean components using the 5-step method.
	This symbol indicates tips, tricks and additional information
	Prerequisites for additional steps
	Finely ground
	Coarsely ground
	Information to optimize the quality of the beverages
	Result or intermediate result for additional steps











2.2 Symbols used in the software





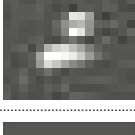

2.2.1 Symbols on the dashboard and on the user interface





If an error occurs, a symbol that represents the affected component will light up on the dashboard *Troubleshooting* [p. 55].

Symbol	Designation	Description
	Franke logo	Call up the maintenance level
	Servicing/cleaning	Machine must be cleaned and/or serviced
	Coffee bean	Bean hopper is empty or not installed correctly
	Grounds container	Grounds container must be emptied
	Rinse	Machine must be rinsed or machine rinses
	Product	
	Payment	Payment active
	Data transfer	Data being transferred
	Individual products counter	
	Individualization	Modify drinks and depiction

Symbol	Designation	Description
	Info	
	Inactive	
	Standby	Switch the machine to standby
	Door	The door is open.
	Service/configuration/ad- ministration	
	Set machine	
	Language	Set language
	Resource settings	Set resources
	Access rights	Manage user permissions
	Descaling	Descalcify coffee machine
	Edit	Edit settings
	Drink settings	

Symbol	Designation	Description
	System information	
	Counters	
	Water filter	
	Drip tray	Drip tray is full or not installed correctly
	Water tank	Water tank is empty or missing
	Powder resource	The powder hopper is empty or has not been inserted correctly
	Milk	Milk container is empty or not installed correctly

2.2.2 Symbols used for navigation and operation

Symbol	Designation	Description
	Cancel button	Cancel preparation
	Select next/previous page	Scroll through menus with multiple pages
	Start button	Start preparation

2.2.3 Depiction of error messages

Highlighted products cannot be prepared. The illuminated symbol on the dashboard takes you to the error message.



If the entire system is affected by an error, the error message will appear automatically.

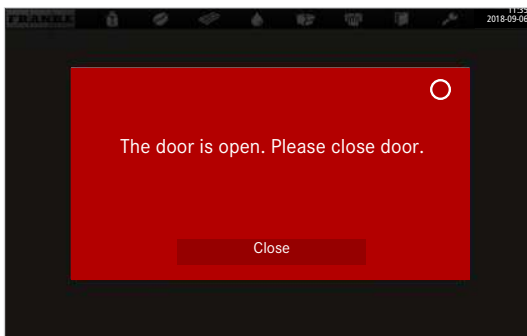













Color code for error messages

- Temporary interruption
- System still fully functional
- System has limited functionality
- Some or all resources are locked

3 SCOPE OF DELIVERY



The scope of delivery may vary, depending on the device configuration. Additional accessories may be obtained directly from your retailer or from Franke Kaffeemaschinen AG in Aarburg, Switzerland.

	Item description	Item number
	Concentrated descaler	560.0589.837
	Cleaning tablets (100 pcs.)	567.0000.010
	Cleaning tablets (USA/Canada)	567.0000.002
	Milk system cleaning agent (dosing bottle)	567.0000.005
	Milk system cleaning agent (dosing bottle) (USA / Canada)	567.0000.006
	Water hardness measuring strips	560.0004.060
	Cleaning brushes	560.0003.728
	Twisted-in-wire brush (Option SU05)	560.0001.019
	Cleaning brush	560.0003.716
	Microfiber cloth	560.0002.315
	Cleaning container	560.0612.966
	Manual set	560.0595.403

4 IDENTIFICATION

4.1 Position of type plates

4.1.1 Coffee machine



The type plate for the coffee machine is located on the right interior wall next to the grounds container.

4.1.2 Cooling unit SU05



The type plate for the cooling unit is located on the left on the internal wall.

4.2 Type codes

4.2.1 Coffee machine

Code	Description
A300	Coffee machine (fully automatic device) Series: A Overall size: 300
1G	1 grinder
2G	2 grinders
1P	1 powder dosing unit
2P	2 powder dosing units
S1	Steam wand
W3	Internal water tank
W4	Water connection

4.2.2 Add-on units

Type key	Description
FM EC	FoamMaster (warm milk and warm milk foam)
MS EC	Milk system with EasyClean cleaning system

5 DESCRIPTION OF MACHINE

5.1 Coffee machine

Introduction

The A300 coffee machine is available with numerous options. Please note that your coffee machine may look different from the configuration shown here.

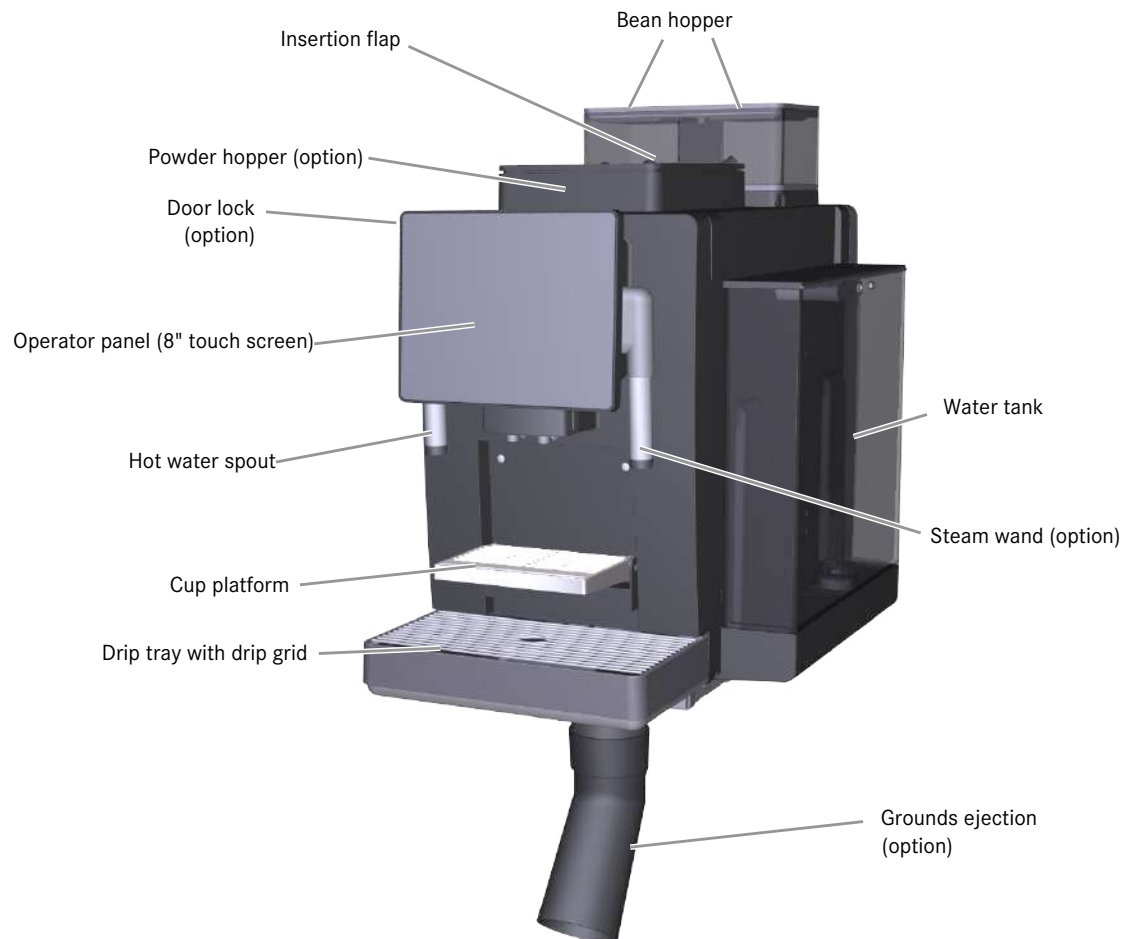

5.1.1 Versions

Water supply	Product type
A300 with mains water connection	A300 NM
	A300 MS EC
	A300 FM EC
A300 with water tank	A300 NM
	A300 MS EC
	A300 FM EC

5.1.2 Standard

- 8" touchscreen
- One grinder (rear LH)
- Hot water spout (left)
- Automatic descaling system

5.1.3 Options

- Additional unit for bean hopper
- Single powder dosing unit
- Twin powder dosing unit
- Steam wand S1 (only with MS EC)
- Grounds ejection (only in conjunction with mains water connection)
- Door lock
- Lockable bean and powder hopper
- Franke Digital Services

5.2 Add-on units

5.2.1 Components of the cooling unit with EasyClean

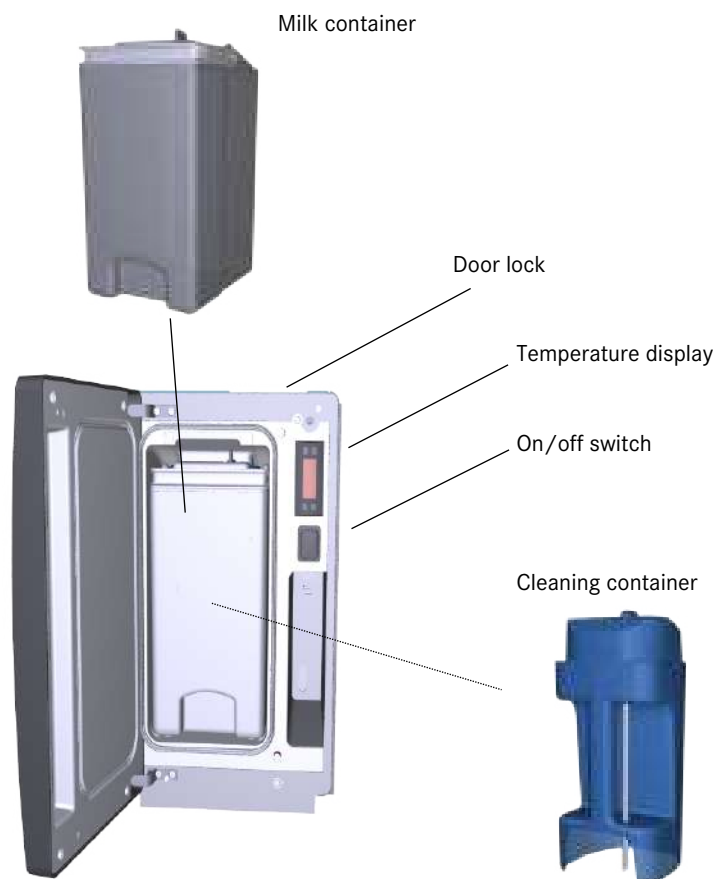

5.3 User interface



1 Use the Franke logo to switch between the maintenance level and product selection

2 Scroll forwards or backwards

5.4 Quick Select operating mode

The Quick Select operating mode is the standard setting for self-service. Once your customer has selected a drink, he/she can adapt it in the second step if product options are activated.

Structure of the user interface

- Level 1: Product selection, up to 5 pages; 6, 12 or 20 product buttons can be displayed per page
- Level 2: Modify drink, select product options, initiate drink-preparation process

Individual adaptations

- Display: 2x3, 3x4, or 4x5 products per page
- Individual arrangement of drinks

6 INSTALLATION

6.1 Preparations

Installation site

- The installation site must fulfil the requirements of the permitted ambient conditions and must not be located outdoors.
- The surface on which the machine is installed must be flat and level.
- Details regarding the space requirements and the hole dimensions can be found in the section entitled *Dimensions of the A300* [► 22]

Electrical connection

- The outlet must be permanently installed at the installation site.
- The outlet must have a suitable connected load and fuse. The required connection values can be found on the type plate of the coffee machine.
- The power connection for the coffee machine must be protected using a residual current circuit-breaker (RCCB).
- The power outlet must be within reach of the power cord.
- No extension cord may be used to connect with the socket.

Wastewater connection (optional)

- The wastewater connection must be equipped with a siphon.
- The siphon must be within reach of the wastewater hose.
- The siphon and the placement of the wastewater hose must be lower than the coffee machine itself.
- The connection to the siphon must use a free-flowing section of hose.

Fixed water connection (optional)

- The mains water connection must be within reach of the water hose.
- The mains water connection must be clean and rinsed.

6.2 Dimensions of the A300



All dimensions are specified in mm.

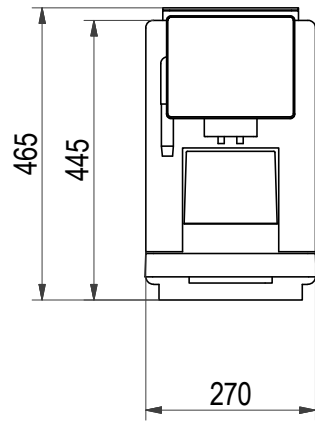

A300 mit Wasseranschluss

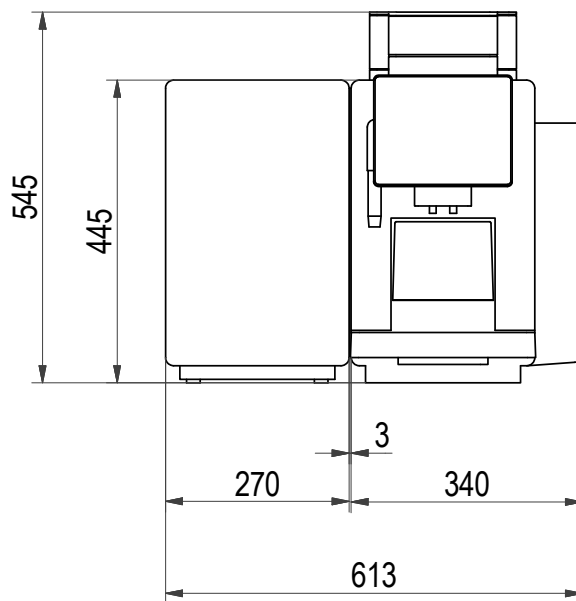
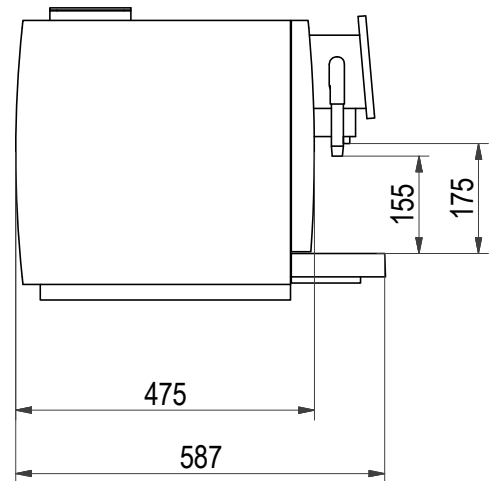

A300/SU05 with water tank and powder hopper

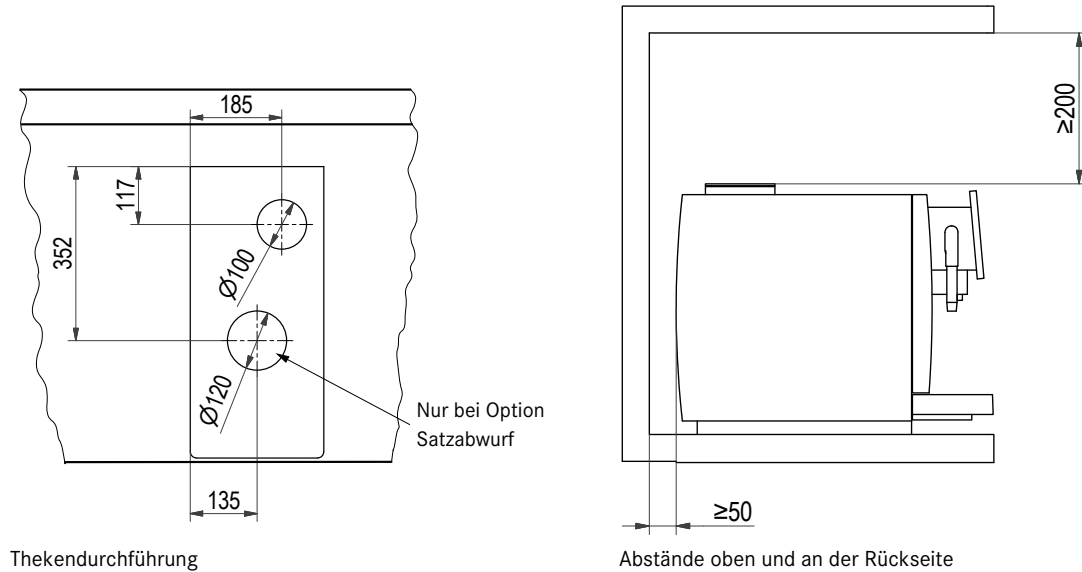

Thekendurchführung

Abstände oben und an der Rückseite

Minimum clearances

- To the rear wall: 50 mm
- Above: 200 mm (for filling and removal of the bean hopper)
- To the right: 100 mm (for opening the door)

6.3 Requirements of the water supply

6.3.1 Water connection

Water pressure	80–800 kPa (0.8–8.0 bar)
Flow rate	> 0.1 l/sec
Water temperature	< 25 °C
Connection to the mains water connection	Union nut G3/8" and metal hose l = 1.5 m Only connect with the hose set provided

- The mains water connection must meet the requirements of the technical data and comply with applicable federal, state, and local regulations.
- The mains water connection must have a backflow prevention device.
- The mains water connection must be equipped with a shut-off valve and a check valve with an upstream filter accessible for inspection. It must be possible for the filter to be removed for cleaning.
- Water from a decalcification system must not be used.
- Filter with at least 100 loops/inch (UL)

6.3.2 Water quality

Total hardness:	4 – 8° dH GH (German total hardness) 7 – 14° fH GH (French total hardness) 70 – 140 ppm (mg/l)
-----------------	--

Carbonate hardness	3–6° dH KH / 50–105 ppm (mg/l)
Acid content/pH value	6.5–7.5 pH
Chlorine content	< 0.5 mg/l
Chloride content	< 30 mg/l
TDS (total dissolved solids)	30 – 150 ppm (mg/l)
Electrical conductivity (measured)	50–200 µS/cm (microsiemens)
Iron content	< 0.3 mg/l

- Color: Clear
- Taste: Fresh and pure taste
- Aroma: No perceptible aroma
- No rust particles in the water

6.3.3 Determining the water hardness with a measuring strip



NOTICE

Machine damage caused by limescale build-up

If the water hardness is set incorrectly, limescale can build up in the coffee machine. Limescale deposits may damage the coffee machine.

- Measure the water hardness during commissioning. Then set the measured water hardness in the menu **Commissioning**.

The hardness level of the water in use determines the capacity of the water filter (only in conjunction with mains water connection) and the amount of water in between descaling cycles. Once the hardness level has been set in the machine program, the coffee machine will automatically prompt you to descale the machine at the correct time.

The hardness level of the water in use determines the capacity of the water filter. If the hardness level in the machine program is known, it will automatically request a filter change at the correct time.

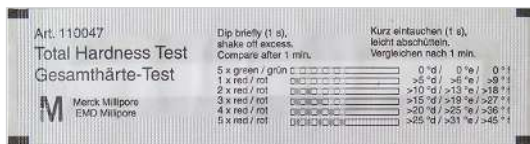

Packaged water hardness measuring strip

- Remove the measuring strip from the packaging.

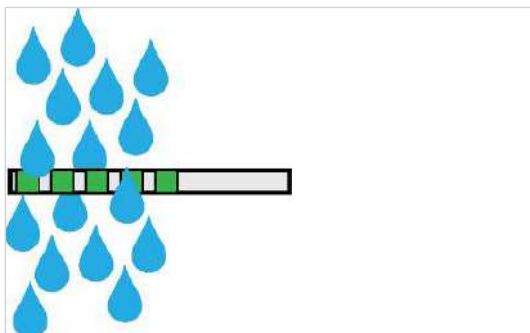

- Dip the measuring strip into the water for 1 second.

- Gently shake off any excess water.



⇒ The color of the measuring strip will change.

- After one minute, read off the water hardness level. The water hardness level corresponds to the number of red-colored fields.
- Enter the measured result into the maintenance menu of the machine *Water settings* [▶ 35].

Conversion table; Descaling prompts for machines without water filter

Hardness level	Result shown on the measuring strip	Water hardness	Descaling prompt after	Mandatory descaling after
1	1 x red	>5° dH/>6°e/>9°fH	100 l	125 l
2	2 x red	>10° dH/>13°e/>18°fH	80 l	100 l
3	3 x red	>15° dH/>19°e/>27°fH	60 l	75 l
4	4 x red	>20° dH/>25°e/>36°fH	40 l	50 l
5	5 x red	>25° dH/>31°e/>45°fH	20 l	25 l

Hardness level	Result shown on the measuring strip	Water hardness
1	1 x red	>5° dH/>6°e/>9°fH
2	2 x red	>10° dH/>13°e/>18°fH
3	3 x red	>15° dH/>19°e/>27°fH
4	4 x red	>20° dH/>25°e/>36°fH
5	5 x red	>25° dH/>31°e/>45°fH

6.4 Setting up and preparing the coffee machine



WARNING

Danger of suffocation

Plastic packaging materials could cause children to suffocate.

- a) Ensure that children have no access to plastic packaging materials.

1. Check packaging for transport damage.
2. Unpack devices.
3. Check that the delivery is complete (see Scope of delivery and order).



NOTICE

Overheating damage

If the clearances around and above the machine are too small, heat may accumulate in the machine and lead to faults.

- a) Maintain the prescribed installation dimensions and clearances.
- b) Take care to ensure that the clearance spaces are not blocked.

6.5 Connect the water supply



NOTICE

Water damage

If the mains water connection is not implemented correctly, this may result in water damage. The operating company is responsible for ensuring that the mains water connection is implemented correctly.

- a) Take into account the data listed regarding *Water connection* [23].
- b) Check that there are no leaks in the mains water connection.



Open-end wrench 19 mm

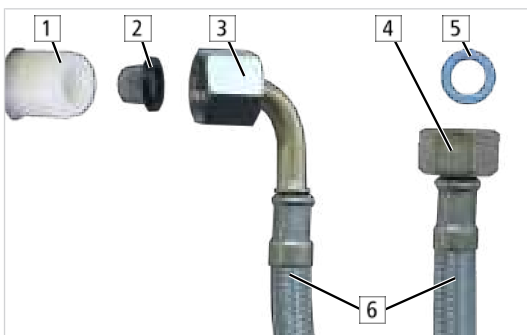

1	Coffee machine	2	Strainer with seal
3	Coffee machine port	4	Water system fitting
5	Gasket	6	Water hose

1. Rinse the water hose and the water supply line thoroughly to clear away any dirt or debris.
2. Connect the water hose with the strainer to the coffee machine.
3. Connect the water hose with the seal to the water system.
4. Fasten the screw joints hand-tight.



5. Open the water supply.
6. Check the fixed water connection for absence of leaks.

6.6 Connecting the wastewater

- ✓ Parts for securing the wastewater hose are present.

1. Connect the wastewater hose to the coffee machine.

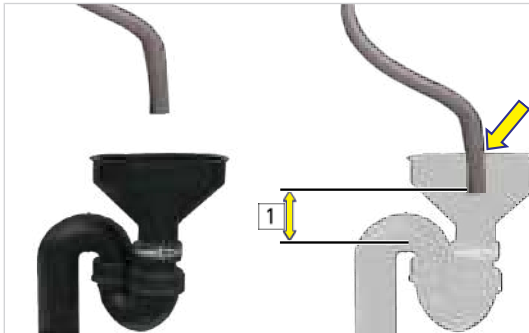

2. Insert the wastewater hose into the siphon so that there is a free flow path [1] of at least 50 mm. The siphon still has to be ventilated.
3. Secure the wastewater hose in this position [arrow] to prevent it from sliding further into the siphon or from being pulled out accidentally.
4. Pour water into the drip tray and check the drain.

6.7 Connecting electrical circuit



WARNING

Risk of fatal injury from electrocution

Connecting to a power supply without a ground fault protective device can result in fatal injury from electrocution.

- a) Ensure that the connection to the power supply is protected by a ground fault protective device.



WARNING

Risk of fatal injury from electrocution

Work improperly performed on electrical systems can lead to electrocution.

- a) Trained and qualified electricians are permitted to work on electrical systems. Instructed persons are permitted to work on electrical systems only under the guidance and supervision of a trained and qualified electrician.



WARNING

Risk of fatal injury from electrocution

Damaged power cords, lines or plug connections can lead to electrocution.

- a) Do not connect any damaged power cords, lines or plug connections to the power supply.
- b) Replace damaged power cables, lines or plug connections.
If the power cord is permanently attached, contact the service technician. If the power cord is not permanently attached, order and use a new, original power cord.
- c) Ensure that the machine and the power cord are not near any hot surfaces such as gas or electric stoves or ovens.
- d) Ensure that the power cord is not pinched and does not chafe on sharp edges.

1. Fuse the electrical circuit.
2. Connect each device to the power grid separately.
3. Activate the electrical circuit.

6.8 Switching the machine on

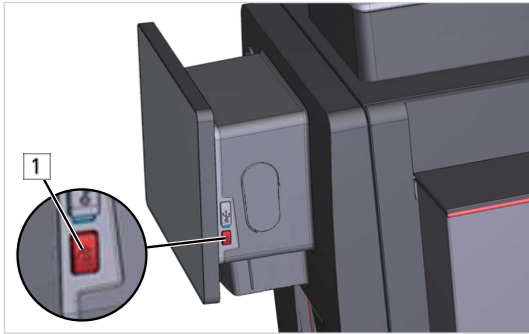

1. Briefly press the button [1].

⇒ The machine starts.

7 SWITCHING ON THE MACHINE FOR THE FIRST TIME



Once the machine is connected to the power grid, it switches itself on. When the machine is switched on for the first time, the software takes you through the basic settings that need to be configured when the machine is commissioned. All basic settings can be changed later *Configuration* [▶ 31].

1. Connect the machine to the mains power supply.
⇒ The machine starts up and launches the installation wizard.
2. Remove the protective film from the screen.
3. Configure the basic settings in line with the instructions on the operator panel – see table below.

Setting the language, time and date

Parameter	Value range	Remarks
Language	<ul style="list-style-type: none"> - de (German) - en (English) - fr (French) - ... Thirty-three languages are available	The language is switched immediately
12/24-hour display	12 hours 24 hours	
Time		
- Hour	0 - 23/0 - 11	Configure hours
- Minute	0 - 59	Configure minutes
Date		
- Day	0 - 31	Set the day
- Month	0 - 12	Set the month
- Year	2019 - 9999	Set the year
Time zone		Select a time zone from the list

Water supply settings

Parameter	Value range	Remarks
Water hardness	Hardness levels 1 - 5	Enter the measured water hardness <i>Determining the water hardness with a measuring strip</i> [▶ 24] The water hardness must be set on machines that have a water tank and machines that are connected to the mains water supply but have no water filter
Water filter	<ul style="list-style-type: none"> - Yes - No 	Only in conjunction with mains water connection
Filter quantity	Water filter type Selection list	Depends on the filter used and the water hardness

7.1 Inserting a descaling cartridge

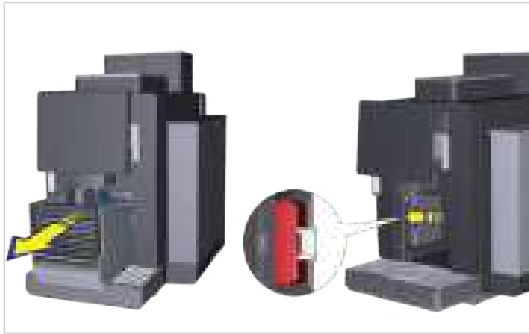

1. Remove the grounds container.
2. Open the door lock (optional extra) with the key.
3. Actuate the locking mechanism on the inside.
4. Open door.



5. Unscrew the screw cap from the cartridge.
6. Remove the seal.
7. Insert the descaling cartridge at an angle from below into the red double pipe.
8. Close door.
9. Replace the grounds container.

7.2 Refilling containers with resources



Only those resources that are available as per the configuration of the A300 are displayed.



The grind coarseness required depends on the drink-preparation method, the type of roasted coffee used and the coffee drink. It is a good idea to use separate grinders to make espresso, caffè crema and decaffeinated coffee. This enables a specific grind coarseness to be set for each different type of roasted coffee used. *Setting the grind coarseness* [▶ 38]

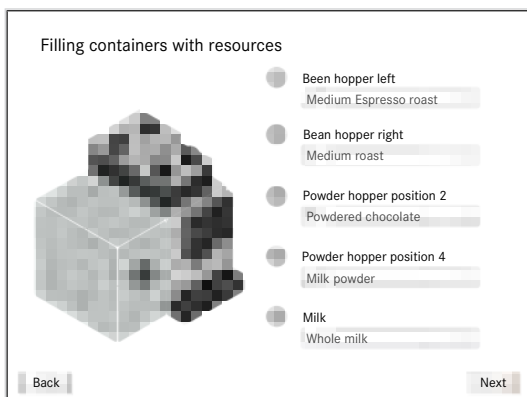

1. Fill the containers with the defined raw materials.

2. Tap **Continue**.

⇒ You have now configured the most important settings and are ready to dispense your first drink.



To adjust the standard drinks, press on the Franke logo in the top left. See also the section entitled *Setting drinks* [▶ 32].

You can change any of the settings that you configured when commissioning the machine at any time by going to the Maintenance menu. *Configuration* [▶ 31]

8 CONFIGURATION

8.1 Call up the maintenance level

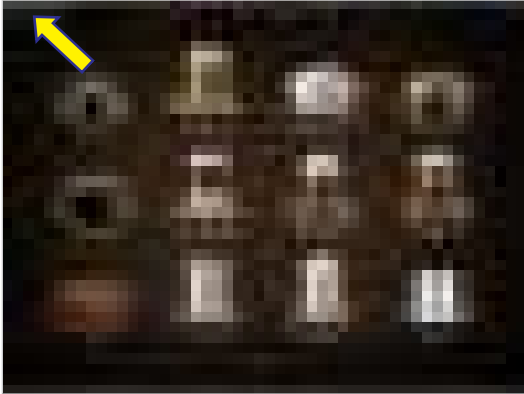

1. Tap the Franke logo at the top left.





2. Enter the PIN.

3. Press OK.

8.2 PIN codes

Default PIN codes are assigned at the factory:

	Owner	Specialist	Operator
Default PIN	1111	2222	7777
My PIN	 ...	 ...	 ...

The PIN codes for key-secured products and **On/Off Machine** can be viewed and changed with the owner role in the **My settings >Access rights** menu.

8.3 My settings

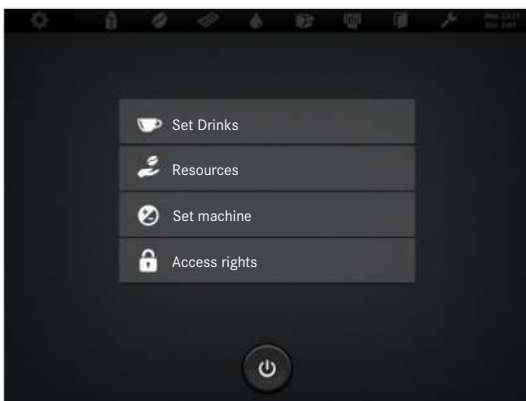

8.3.1 Setting drinks



Action	Input/function	Remarks
Export/Import	<ul style="list-style-type: none"> - Back up product offering package (POP) - Load backup 	<ul style="list-style-type: none"> - Back up drink settings to a USB stick, e.g. before a software update - Load drink settings from a USB stick to the coffee machine
Sort drinks		<ul style="list-style-type: none"> - Change the positions of the drinks - Set the number of drinks to be displayed (2 x 3, 3 x 4 or 4 x 5) <ol style="list-style-type: none"> 1. Tap the Sort drinks button. 2. Tap the drink you wish to move. 3. Tap the desired position for the drink.
Edit		Modify the highlighted drink
Display/hide		Show or hide available drinks
Copy		Copy existing drinks to use as the basis for a variant
Adjustable	<ul style="list-style-type: none"> - Yes - No 	<p>Activate/deactivate. When this function has been activated, a drink can be modified in the following ways after being selected:</p> <ul style="list-style-type: none"> - Cup size - Type of bean, if more than one bean type has been set - Flavor strength <p><i>Quick Select operating mode [▶ 20]</i></p>

Modifying a drink



1	Active drink	2	Resource (coffee, milk, etc.)
3	Configuration parameters	4	Slide control

8.3.2 Set resources



You can change the settings that you configured when commissioning the machine (*Refilling containers with resources* ▶ 30) at any time.

For each container, a list of available resources is stored from which you can choose.

Allocating resources

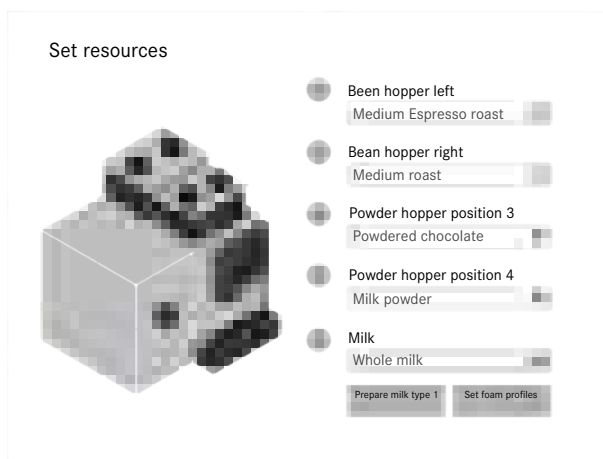

1. To allocate a resource to a container, tap the preset resource type.
2. Select the appropriate resource type from the list.
3. Repeat this process for all containers.
4. To fill the milk lines, select **Prepare milk type 1**.

Set foam profiles



On the A300 FM EC, you can configure the foam profiles for firm and liquid foam (standard settings: Liquid foam 10% air, firm foam 35% air).

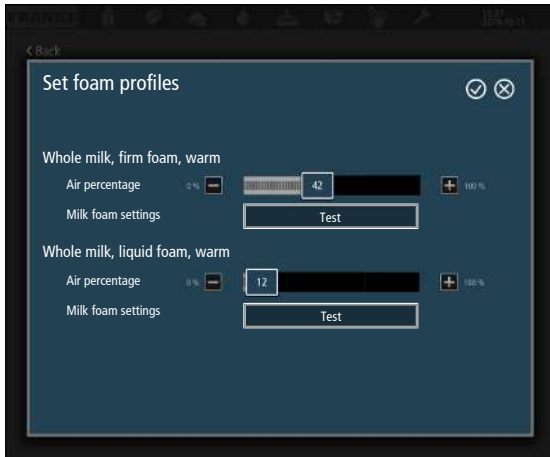

1. Tap **Set foam profiles**.
2. Use the slide control to adjust the air percentage in firm and liquid foam.
3. Click **Test** to check whether the foam has the quality you require.
4. Repeat this process if necessary.

8.3.3 Set machine

Language

Parameter	Value range	Remarks
Language	<ul style="list-style-type: none"> - de (German) - en (English) - fr (French) - ... 	The language is switched immediately
Thirty-three languages are available		

Date and time

Parameter	Value range	Remarks
12/24-hour display	12 hours 24 hours	
Date		
- Day	0 - 31	Set the day
- Month	0 - 12	Set the month
- Year	2019 - 9999	Set the year
Time		
- Hour	0 - 23/0 - 11	Configure hours
- Minute	0 - 59	Configure minutes
Time zone		Select a time zone from the list

Timers

Set-ups

Parameter	Value range	Remarks
Saving energy	<ul style="list-style-type: none"> - Active - Off 	If Active , the waiting time can be set Range: 15 - 120 minutes
Switch on/off automatically	<ul style="list-style-type: none"> - Active - Off 	<ul style="list-style-type: none"> - Switch timer on or off - Use the pin to adjust the timer

Adjusting timers

Parameter	Value range	Remarks
Action	<ul style="list-style-type: none"> - Switch on automatically - Switch off automatically 	Select timer operation
Hour	0 - 23	Set switch-on/switch-off time
Minute	0 - 59	
Repeat every Monday	- Yes	Activate/deactivate the timer depending on the day
...	- No	
Repeat every Sunday		

Water settings

Water supply settings

Parameter	Value range	Remarks
Water filter active	<ul style="list-style-type: none"> - Yes - No 	<ul style="list-style-type: none"> - Yes: • Slide control appears for entering the duration of use/the water quantity for the water filter (depending on the filter used) - No: Set water hardness
Water hardness	Hardness levels 1 - 5	Use the slide control to set the measured water hardness <i>Determining the water hardness with a measuring strip</i> [▶ 24] The water hardness must be set on machines that have a water tank and machines that are connected to the mains water supply but have no water filter

Factory settings

Parameter	Value range	Remarks
Reset to factory settings		All settings, including your own products, will be lost!
Reset products to factory settings		Your own product settings will be lost!

System information

Category	Value
Total version	Machine software version that is currently installed
Sub-system versions	
Machine	Machine type
Serial number	[Serial number]
FPC	Franke product catalog version that is currently installed
POP (product offering package)	Product offering package version that is currently installed (product positioning/sorting)
License	Active license for Franke Digital Services, if present
Ethernet device A	
IP address	
MAC address	

8.3.4 Access rights

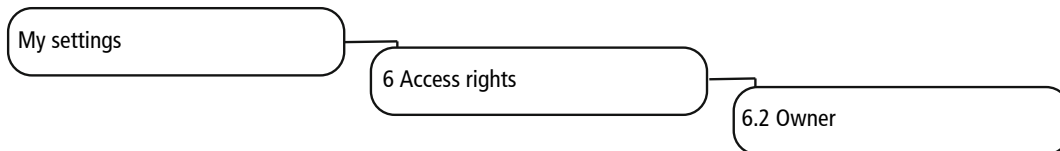

The roles are organized into the following hierarchy: Service technician > Owner > Operator > Maintenance staff.

Rollen und Rechte

Action	Service technician	Owner	Specialist	Operator
Change PIN and activate test products	Yes (for all roles)	Yes (for lower-level roles)	No	No
Add/change/remove/adapt products	Yes	Yes (reduced scope)	No	No
View counter	Yes	Yes	Yes	No
Perform cleaning	Yes	Yes	Yes	Yes
Update software (USB)	Yes	No	Yes	No

9 FILLING AND EMPTYING

9.1 filling the machine



NOTICE

Incorrect filling of the hoppers

Incorrectly filling the hoppers can produce defective products and the machine can be damaged as a result.

- a) Fill the bean hopper with coffee beans.
- b) Fill the powder hopper with powder suitable for automatic coffee makers.

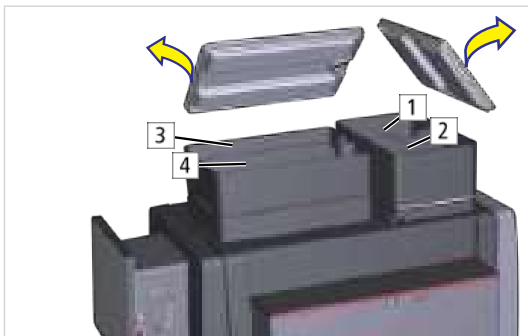

Container positions

1	Bean hopper position 1	2	Bean hopper position 2
3	Powder hopper position 3	4	Powder hopper position 4

9.2 Using and storing roasted coffee beans



The crucial factor when it comes to optimal in-cup quality is the freshness of the coffee beans used.

- Do not pour roasted coffee beans into the bean hoppers until you are just about to make a drink. This ensures that you retain as much of the flavor as possible. Only pour in as much as you intend to use in the next few hours on the same day. Bean hoppers are not storage containers.
- Always close the bean hoppers properly. Make sure that you reseal open coffee packets properly after use.
- Store roasted coffee in a cool, dry place away from direct sunlight. Do not store it in a refrigerator, however.
- Order only as much roasted coffee as you need - ordering small quantities regularly ensures that you always drink coffee at its freshest.
- Opt for smaller packets, e.g. 250 or 500 g instead of 1 kg. This way, you avoid having to store open packets or having too many beans in your bean hoppers.

Monitor how much you use over a specific period, e.g. over the course of a week. Take note of when you need to refill and how much, and use this information to ensure that you always have fresh beans available for the next few hours. Mark the maximum fill level on each bean hopper, e.g. using a sticker.

9.3 Filling beans



WARNING

Risk of injury

If objects find their way into the bean hopper or grinder, splinters may be ejected, leading to injury.

- a) Never insert any objects into the bean hopper or grinder.

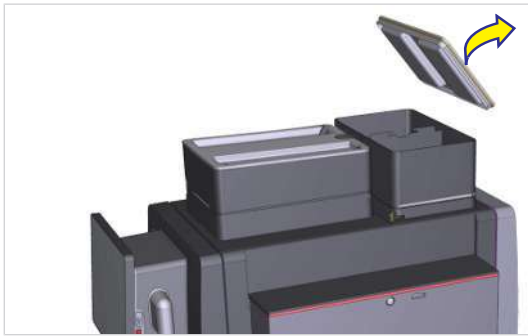

1. Lift the bean hopper lid.

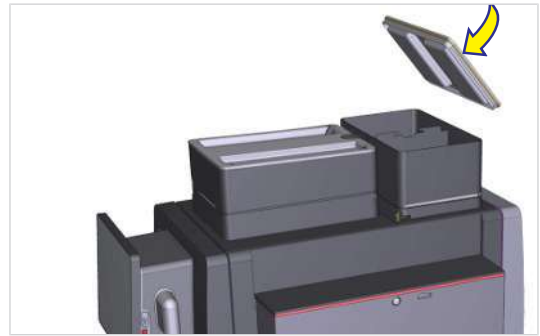

3. Fit the lid.

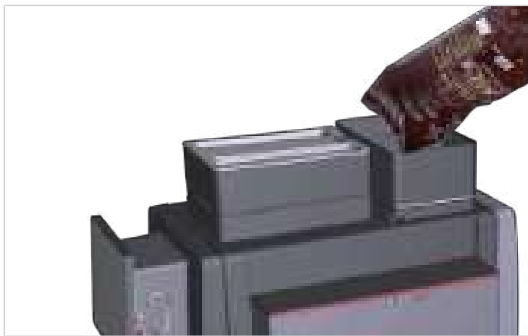

2. Add coffee beans.

9.4 Setting the grind coarseness



The grind coarseness can be adjusted individually for each grinder. Default setting: Center.

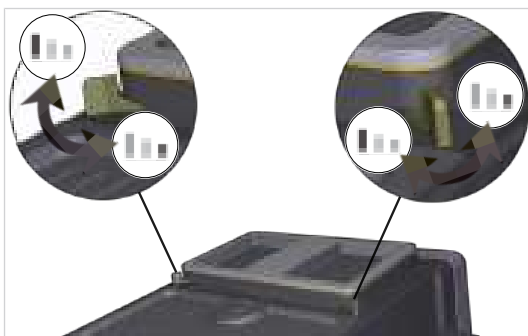

- For a finer grind, push the lever to the right.
- For a coarser grind, push the lever to the left.

9.5 Filling powder

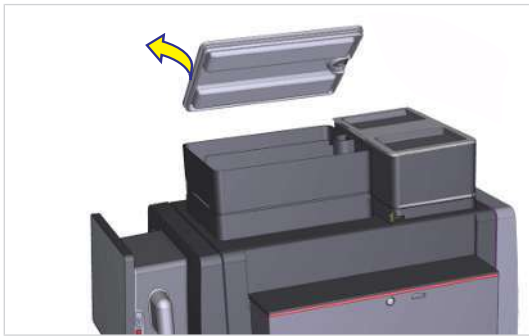

1. Lift off the powder hopper lid.

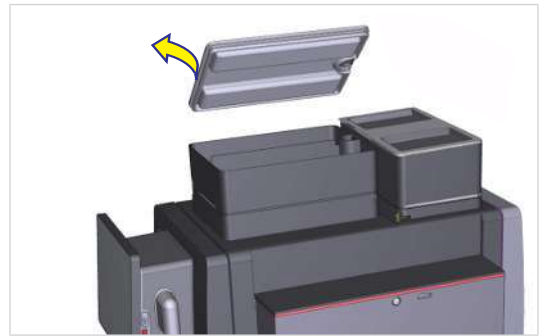

3. Replace the lid.



2. Fill with powder that is suitable for automatic coffee makers.

9.6 Filling the water tank



NOTICE

Machine damage

Pouring milk into the water tank can potentially damage the machine.

- a) Fill the water tank with water only.
- b) Disconnect the machine from the power supply and contact the service department if the water tank has been inadvertently filled with milk.



Optimal *Water quality* [p. 23] is essential for the quality of the beverage, as well as for a long service life and reliable operation of the machine.



1. Open the lid.



2. Lift up the water tank and remove it.
3. Clean the water tank if necessary.



4. Fill the water tank with fresh water up to the mark. *Water quality* [▶ 23]



5. Replace the full water tank and close the lid.

9.7 Filling milk



CAUTION

Germes in unpasteurized milk

Germes in unpasteurized milk could pose a health hazard.

- a) Do not use any unpasteurized milk.
- b) Only use pasteurized or long-life milk.



NOTICE

Machine damage

Using incorrect liquids can damage the machine.

- a) Only fill the milk container with milk.
- b) Use water and a mild cleaner to clean the milk container.



NOTICE

Impaired drink quality

Incorrect handling of milk can lead to quality problems.

- a) Only clean containers should be filled with milk.
- b) Only use pre-cooled milk (2–5 °C).
- c) Only touch the inside of the milk container, the milk hoses, and the milk lid after sanitizing your hands, or wear disposable gloves.



The milk system is prepared semi-automatically after a cleaning or a filling procedure. Please observe the instructions in the event messages. Access to the event messages is through the dashboard.

9.7.1 Filling milk for the SU05



1. Open door.



2. Switch on the cooling unit.



⇒ The current cooling chamber temperature is displayed.

- 3. Remove the milk container lid along with the suction hose and place it on a clean surface.
- 4. Fill the container with up to 5 l of chilled milk.
- 5. Replace the milk container lid.
- 6. Slide the milk container all the way into the cooling chamber.



7. Close door.

9.8 Emptying the grounds container



NOTICE

Formation of mold

Coffee residue can lead to the formation of mold.

- a) Empty and clean the grounds container at least once a day.



1. Remove the grounds container.

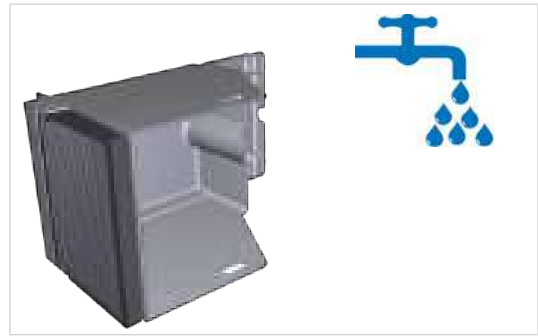

3. Clean and dry the grounds container.



2. Empty grounds container.



4. Replace grounds container.

9.9 Empty the powder hopper



NOTICE

Contamination from powder

Powder can fall from the powder hopper.

- a) Always transport the powder hopper in an upright position and ensure it is closed.

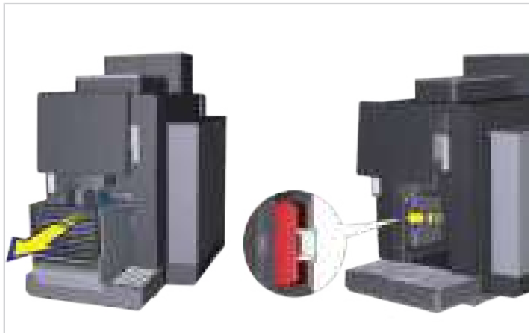

1. Remove the grounds container.
2. Open the door lock (optional extra) with the key.
3. Actuate the locking mechanism on the inside.
4. Open door.

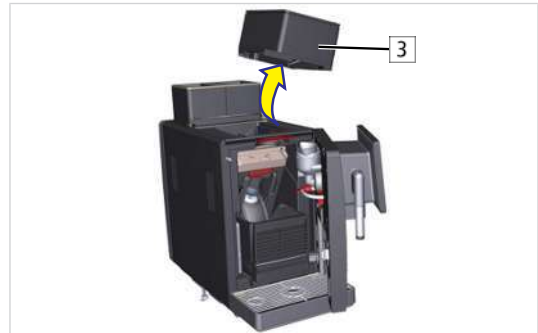

6. Lift up the powder hopper [3] and remove it.
7. Empty the powder hopper.
8. After replacing the empty powder hopper, push in the locking slide.
9. Close door.

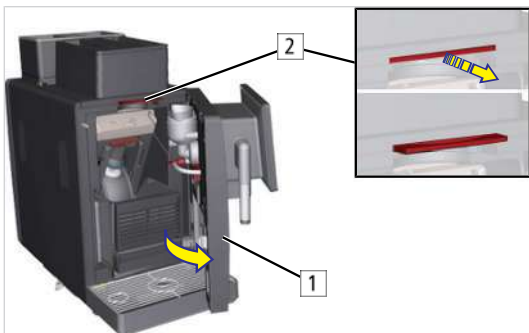

5. Pull the locking slide [2].



NOTICE

Impairment of function

If the powder hopper is not locked correctly, this may impair both the operation of the coffee machine and the product quality.

- a) Push the locking slide all the way in.

9.10 Emptying the cooling unit



CAUTION

Health hazard due to germ formation

Inadequate cleaning can result in food residues accumulating in the machine and at the outlets, thereby contaminating products.

- a) Do not use the machine unless it has been cleaned according to the instructions.
- b) Clean the machine daily in accordance with the instructions.
- c) Inform operating personnel of the necessary cleaning measures.



NOTICE

Spoiled milk

Insufficient cooling or hygiene can cause milk to spoil.

- a) Only use pre-cooled milk (2.0–5.0 °C).
- b) Only store milk in the cooling unit when the cooling unit is in operation. When the cooling unit is not in operation, e.g. overnight, store the milk in a refrigerator.
- c) Clean the machine and cooling unit once a day.
- d) Only touch the suction hose, the inside of the milk container, and the milk lid after sanitizing your hands, or wear disposable gloves.
- e) Place the container lid with the suction hose on a clean surface only.

1. Open the door.
2. Pull out the milk container.



3. Store the milk in a refrigerator or dispose of it if necessary.



4. Clean the milk container, the parts that come into contact with milk, and the cooling chamber.
5. Insert the clean milk container.
6. Switch off the cooling unit if it is no longer required. After switching off, do not close the cooling unit door all the way, but leave it slightly open in order to prevent the formation of odors.

10 PREPARING DRINKS



WARNING

Risk of scalding

Hot drinks can lead to scalding.

- a) Always be careful with hot drinks.
- b) Use only suitable drinking vessels.

10.1 Dispensing drinks with Quick Select

1. Place an appropriate drinking vessel under the spout.



2. Select a product.

⇒ The product preview will appear.



3. Select product options.

4. Press the green button to initiate the drink-preparation process.

⇒ The drink is being prepared.



- ⇒ The product selection screen appears when the drink is ready.

11 CLEANING

11.1 Introduction

The perfect coffee experience depends on a perfectly cleaned coffee machine. Clean your coffee machine at least once a day and more frequently if necessary.

The automatic cleaning process involves cleaning the coffee machine and cleaning the cooling unit.

Required accessories

- Cleaning tablets
- Microfiber cloth
- Brush set

Additional accessories required for **machines with a milk system**

- Milk system cleaning agent
- With the SU05: cleaning container



NOTICE

Soiled accessories

Soiled accessories can have a negative affect on the functionality of the machine and the quality of the drinks produced.

- a) Clean the accessories by using the 5-step method.
- b) Follow the applicable instructions for accessories.



The removable parts of the coffee machine are not dishwasher-safe.

Other areas to be cleaned manually

- Inner surfaces of the cooling chamber
- Inside of the door, lip seal
- Milk container, milk container lid
- Suction hose, suction nozzle
- Powder hopper

Cleaning weekly [▶ 47]



Clean the removable components of your coffee machine using the 5-step method.

11.2 Starting the cleaning process



WARNING

Risk of scalding

Hot liquids and steam escape during cleaning and can lead to scalding.

- a) Keep hands away from the spouts and nozzles during this process.



When the cleaning cycle is complete, the machine either switches back to the maintenance level or the energy saving mode. Your service technician can set the desired option for you.

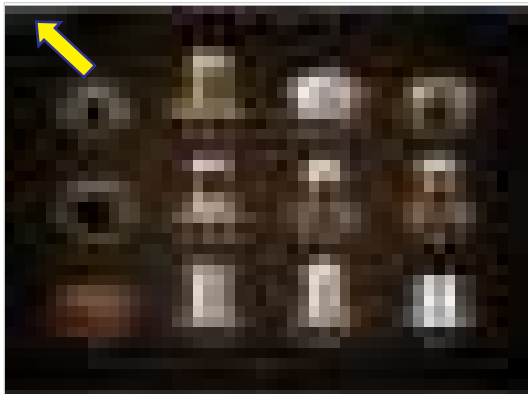

1. Tap the Franke logo at the top left.



- 2. Enter the PIN. *PIN codes* [▶ 31]
- 3. Press OK.

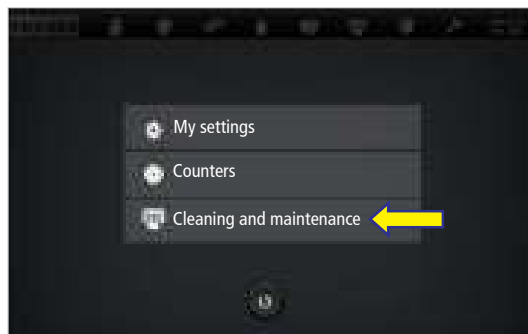

4. Select **Cleaning and maintenance**.

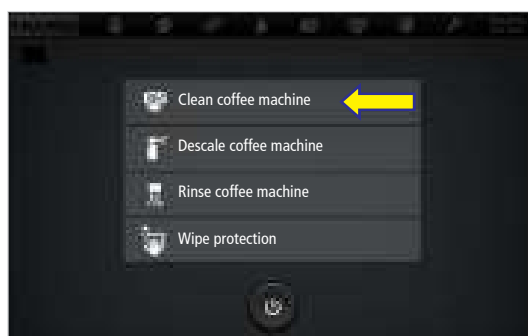

- 5. Tap **Clean Coffee Machine**.
- 6. Confirm message with **Yes** to begin the cleaning process.
- 7. Follow the instructions on the user interface and confirm the individual steps by selecting **Next**.
- ⇒ The machine shows the next step.

11.3 Cleaning weekly



In addition to the daily cleaning process, clean the machine components listed in this section at least once a week. Clean the machine immediately if you find that it is dirty or clogged. Follow the cleaning instructions when doing so.

11.3.1 Cleaning the water tank



Optimal *Water quality* [▶ 23] is essential for the quality of the beverage, as well as for a long service life and reliable operation of the machine.



Inspect the water tank daily for dirt and limescale. If there is any dirt or limescale, clean it off immediately.



1. Remove and empty the water tank.
2. Clean the water tank using the 5-step method.

11.3.2 Cleaning the powder hopper



1. Remove the grounds container.
2. Open the door lock (optional extra) with the key.
3. Actuate the locking mechanism on the inside.
4. Open door.

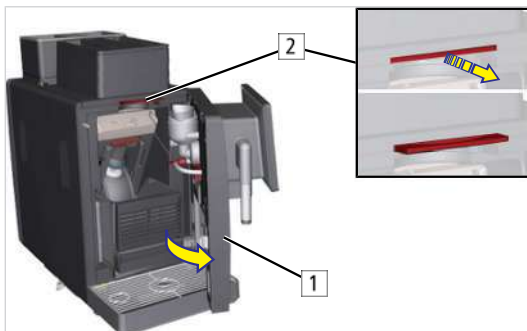

5. Pull the locking slide [2].



6. Lift up the powder hopper [3] and remove it.
7. Empty the powder hopper.
8. Clean the powder hopper with a cloth. Use detergent if necessary. Wipe the inside of the hopper with a dry cloth.
9. Replace the powder hopper.
10. Push in the locking slide.
11. Close the door and reinsert the powder hopper.

11.3.3 Cleaning the drip tray and drip grid

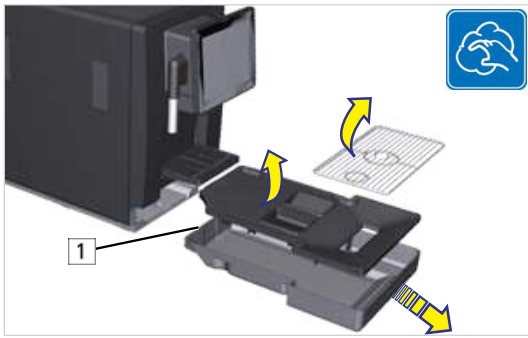

1. Clean the drip tray and drip grid using the 5-step method.

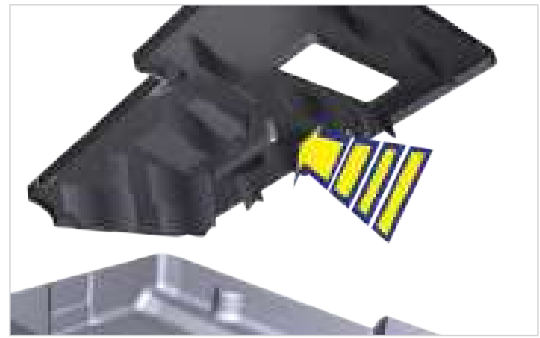

2. Thoroughly clean the projecting features on the underside of the drip tray lid.



The rear [1] of the drip tray must be clean and dry, both inside and out. If it is not, this may cause the drip tray's continuous level sensor to issue an alert in error.



If the coffee machine has been connected to the wastewater system, there are two O-rings [2] on the rear of the drip tray. These must be moistened with water so that the drip tray can lock in place properly. Otherwise, the capacitive sensor cannot detect the drip tray.

11.3.4 Cleaning the screen

1. Tap the **Settings** symbol at the top left.
2. Select **Cleaning and maintenance**.
3. Select **Wipe Protection**.

⇒ The operating interface is locked for 20 seconds.

4. Clean the surface with a damp cloth.

11.3.5 Cleaning the surface of the machine

1. Clean the surface of the machine with a damp cloth.

2. If necessary, use a mild cleaner. **NOTICE! Do not use abrasive cleaners.**

11.4 Rinsing coffee machine



WARNING

Risk of scalding

Hot water is released during rinsing.

- a) Keep hands away from the spouts and nozzles during this process.
- b) Do not place anything on the drip grid.
- c) IN CASE OF SCALDING: Immediately cool the affected area and, depending on the severity of the injury, consult a doctor.



Rinsing is not a substitute for daily cleaning! Rinsing is necessary to remove residue build-up in the coffee and milk systems.

The machine automatically rinses after certain time intervals as well as when it is switched on or off.



1. Tap the Franke logo at the top left.



2. Enter the PIN. *PIN codes* [▶ 31]
3. Press OK.

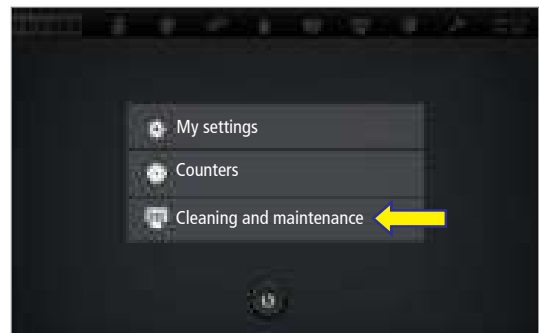

4. Select **Cleaning and maintenance**.

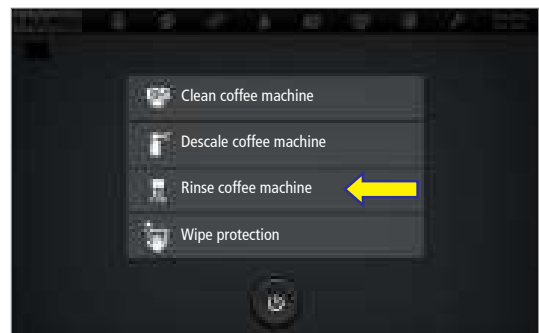

5. Tap **Rinse Coffee Machine** and confirm.
⇒ The coffee machine is being rinsed.

11.5 Care kit



Over time, some of the coffee machine's components may be subject to wear or may become very dirty, and will need to be replaced. This may be the case even before the service technician is due to carry out scheduled maintenance work. We have compiled a list of the parts in question to make it easy to reorder them. You can replace the following components yourself.











Image	Quantity	Item number	Item description	Remarks
	1	560.0001.696	Brewing module dia. 43 with 0.6 mm orifice	The item number can be found on the label on the side of the brewing module. The following section describes the necessary steps. <i>Replacing the brewing unit [▶ 52]</i>
	1	560.0001.697	Brewing module dia. 50E with 0.6 mm orifice	The item number can be found on the label on the side of the brewing module. The following section describes the necessary steps. <i>Replacing the brewing unit [▶ 52]</i>
	1	560.0593.645	FCS4070 FM EC frother head	See type plate to find out which version (FM or MS). The type plate is located inside the machine. <i>Coffee machine [▶ 16]</i>
	1	560.0594.309	MS EC FCS4070 frother head	See type plate to find out which version (FM or MS). The type plate is located inside the machine. <i>Coffee machine [▶ 16]</i>
	1	560.0589.901	FCS4070 double milk spout	FM and MS versions are identical
	1	560.0613.850	Single milk spout	
	1	560.0001.074	Suction hose, assembled, 300 mm	Milk suction line for SU05 cooling unit <i>Components of the cooling unit with EasyClean [▶ 19]</i>
	1	560.0486.469	Hose dia. 9/5x1000 MVQ	1000 mm suction hose for all other milk systems. Shorten the hose as required. The KE200 cooling unit requires a hose that is 400 mm long.
	1	560.0001.187	Mixer chamber	For powder system
	1	560.0580.820	Mixer chamber lid	For powder system

Image	Quantity	Item number	Item description	Remarks
	2	560.0578.001	O-ring 13x1.5 EPDM	Seal for drip tray with drain Only for versions set up for mains water connection

11.5.1 Replacing the brewing unit

1. Empty the machine and disconnect it from the mains power supply.
2. Remove the grounds container from the machine.
3. Open the machine's door.



4. Release the brewing module lock in counter-clockwise direction.



5. Take out the brewing module by pulling it forwards.
6. Insert the new brewing module.
7. Fasten the brewing module locking mechanism in the clockwise direction.
8. Close the machine's door.
9. Place the grounds container back into the machine.
10. Connect the machine to the mains power supply.

12 DESCALING

To maintain consistently high in-cup drink quality and ensure that the coffee machine runs reliably, the machine must be descaled regularly. For this purpose, the A300 has an automatic descaling system. If descaling is necessary, the coffee machine indicates this on the operator panel. Limescale has a particular tendency to build up in the new, energy-saving heating cartridge.



To descale the machine, only use the descaler concentrate from Franke (item number 560.0589.837). This guarantees reliable descaling results.

- a) Make sure that you order descaler concentrate in good time so that you can descale the coffee machine immediately when the prompt appears on the coffee machine operator panel.

12.1 Descaling repeat interval

When you commission the A300, you will be prompted to measure the water hardness and to enter this into the software *Determining the water hardness with a measuring strip* [▶ 24]. This value is used to calculate the amount of water until the machine will next need to be descaled.

Machines with no water filter

A descaling prompt is displayed when the calculated water quantity is reached or, at the latest, after 12 days of operation. The A300 can be used for another 2 days after the descaling prompt is first displayed. After this period, the machine is disabled until descaling is carried out.

Machines with a mains water connection and water filter

A descaling prompt is displayed after 12 days of operation. After the descaling prompt is first displayed, the A300 can continue to be used until the remaining water is used up. After this period, the machine is disabled until descaling is carried out.

12.2 Descale

If descaling is necessary, a message is displayed on the operator panel. The message can be closed so as not to disrupt operation. There are the following options with regard to initiating the descaling process:

- Descaling when cleaning is next carried out (default setting)
- Descaling independently of cleaning – descaling is initiated automatically at a specified time
- Manually initiating descaling



NOTICE

Discontinuing descaling

Applies to machines with a water tank: If the water tank is empty or the drip tray is full, automatic descaling is not carried out.

- a) Empty the drip tray before cleaning/descaling.
- b) Fill the water tank before cleaning/descaling.
- c) Position the cleaning container on the drip grid in accordance with the instructions on the operator panel.

12.2.1 Descaling after cleaning

With the default setting, when descaling is due it is initiated straight after cleaning is next carried out without requiring any further confirmation. No additional action is required on the part of the operator. Descaling takes approx. 15 - 25 minutes, depending on the machine model. If descaling is due, the system checks whether there is sufficient descaler concentrate before the cleaning process begins. If there is insufficient descaler concentrate, a prompt to replace the descaling cartridge is displayed. *Inserting a descaling cartridge [▶ 30]*

12.2.2 Descaling independently of cleaning



To prevent the descaling process from disrupting operation, your service technician can set a time for the descaling process to run outside of your operating hours.

12.2.3 Initiating descaling manually



WARNING

Risk of scalding

Hot liquids and steam escape during descaling and can lead to scalding.

- a) Keep hands away from the spouts and nozzles during this process.

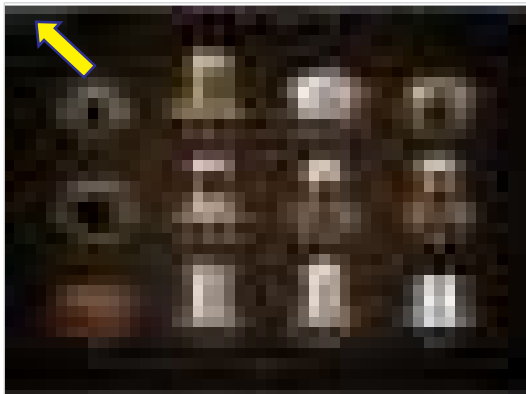

1. Tap the Franke logo at the top left.



2. Enter the PIN. *PIN codes [▶ 31]*

3. Press OK.

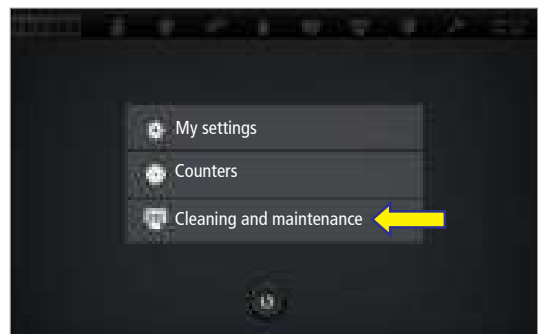

4. Select **Cleaning and maintenance**.

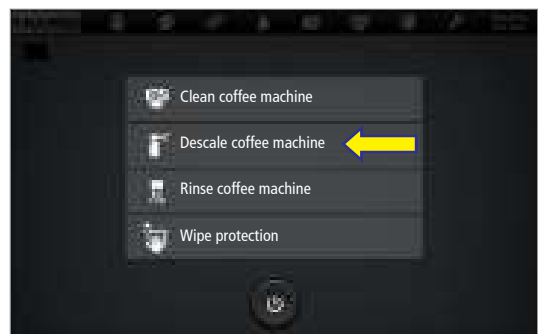

5. Select **Descaling**.

⇒ The automatic descaling process starts and instructions are displayed regarding the next steps to be taken.

13 TROUBLESHOOTING

13.1 Error messages

If an error occurs, a symbol on the dashboard is highlighted in a particular color, depending on the type of error. The user can tap on this to display a window with further information and troubleshooting instructions.

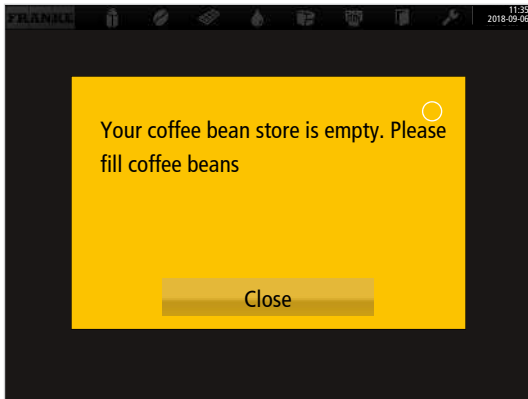

A message with instructions



The machine must be restarted in the event of serious errors.

- a) *Restart machine* [▶ 57].
- b) Check the power supply if the machine fails to start.
- c) Contact your service technician if the machine cannot be started or if you are unable to rectify the error.

13.1.1 Color code for error messages

Temporary interruption
System still fully functional
System has limited functionality
Some or all resources are locked

13.2 Troubleshooting on the coffee machine

Error message/problem	Possible cause	Measure
The error message E663 Drip tray full is displayed even though the drip tray has been emptied	Sensor signal disrupted due to residual substances in the drip tray	Clean and dry the inside of the drip tray. Also clean and dry the drip tray's mounting bay
	Sensor signal disrupted due to moisture on the rear of the drip tray	Clean and dry the rear of the drip tray

Error message/problem	Possible cause	Measure
Milk is frozen	Cooling unit target temperature is set too low	Set target temperature 1 - 2 °C higher <ul style="list-style-type: none"> - SU05 cooling unit: Press and hold the Set button on the temperature controller until the target temperature flashes. Use the navigation buttons to increase the target temperature. Use the Set button to confirm the new target temperature. - KE200: A temperature controller is located to the rear of the KE200. Use this to set the required temperature
Milk is frozen (water in the cooling chamber)	The cooling unit door seal is not leak-tight	Make sure that the seal is fitted correctly and that the door closes properly
Cooling unit milk temperature is not being reached	Inadequate air circulation around cooling unit	Ensure that the required minimum clearance is present between the cooling unit and the wall (at least 50 mm)
Descaler concentrate not being dispensed (error message E409)	Descaling cartridge seal is damaged or clogged or descaling cartridge is empty	Check the descaling cartridge fill level. Check the red adapter with the sealing ring and clear away any descaler crystals. Run the descaling process again
Descaling cartridge needs replacing despite not being empty	Descaling cartridge seal is damaged or clogged	Insert a new descaling cartridge, check the red adapter with the sealing ring and clear away any descaler crystals
Flowmeter error 1 (error message E79)	Water flow disrupted	Check the water tank/mains water connection coupling <p>If the error message appears while a product is being dispensed, the brewing module strainer is probably blocked</p> <ul style="list-style-type: none"> - Increase the grind coarseness and/or reduce the grind quantity - Remove the brewing module and rinse it out - Initiate the coffee machine cleaning process
Touchscreen not responding correctly	Machine software overloaded	There are two different troubleshooting methods: <ul style="list-style-type: none"> - Method 1: Press and hold the red button on the right-hand side of the operator panel for 10 seconds to restart. - Method 2: Disconnect the coffee machine from the power grid. Wait 1 minute before reconnecting the coffee machine to the power grid. Briefly press the red button on the right-hand side of the operator panel to switch it back on
Water level in water tank not being detected	Residual substances or deposits on the water tank's internal wall	Thoroughly clean and rinse out the water tank

Error message/problem	Possible cause	Measure
No milk or just milk foam	Suction hose/milk line has a leak	Check the position of the spout insert and, if necessary, clean it. SU05 cooling unit: Check the O-ring on the suction hose's coupling. Check the suction hose and, if necessary, replace it
Milk is not flowing correctly out of the milk spout	The milk spout was reinstalled incorrectly when it was last cleaned	Initiate the coffee machine cleaning process, and reinstall the milk spout as per the instructions on the touchscreen. The milk spout is also part of the care kit – see <i>Care kit</i> [▶ 51]

13.2.1 Restarting the machine

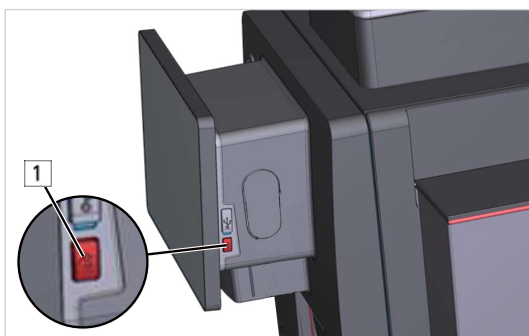

1. Press and hold the button [1] for 10 seconds.

- ⇒ The machine will restart.
- ⇒ The start screen is displayed.

13.3 Help with problems concerning product quality

Problem	Possible causes	Possible solutions
Coffee tastes stale	Grind too coarse	Select a finer grind (see Setting the grind coarseness)
	Too little coffee	Increase the amount of coffee
	Temperature too low	Increase the temperature
	Coffee is old	Use fresh coffee
	Bean hopper not locked correctly	Check the bean hopper locking mechanism (see Emptying the bean hopper, Setting the grind coarseness)
Coffee tastes strange	Poor grind	Contact customer service
	Minimal coffee usage	Pour a small amount of coffee beans into the bean hopper
	Spoiled coffee beans	Replace coffee beans
	Residual cleaner	Rinse the machine
	Dirty cup	Check dishwasher
	Poor water quality (chlorine, hardness, etc.)	Have the water quality checked (see <i>Water quality</i> [▶ 23])
Coffee tastes bitter	Temperature too high	Lower coffee temperature
	Grind too fine	Select a coarser grind (see Emptying the bean hopper, Setting the grind coarseness)

Problem	Possible causes	Possible solutions
	Coffee quantity too low	Increase the amount of coffee
	Roast too dark	Use lighter coffee roast
Coffee tastes sour	Temperature too low	Increase coffee temperature
	Roast too light	Use darker coffee roast
	Grind too coarse	Select a finer grind (see Emptying the bean hopper, Setting the grind coarseness)
Consistency of powder products	Viscous	Use less powder, use more water
	Watery	Use more powder, use less water
	Powder clumping or moist	Clean and dry powder system
Taste of powder products	Too sweet	Use less powder, use more water
	Not sweet enough	Use more powder, use less water
	Strange taste	Clean powder system

14 TECHNICAL DATA

14.1 Capacities in accordance with DIN 18873-2:2016-02



This data assumes a mains voltage of 230 V.

Hourly capacity	Single preparation (cups per hour)	Double preparation (cups per hour)
Espresso	124	164
Coffee/caffè crema	77	98
Hot water (200 ml)	90	-

14.2 Technical data of the coffee machine

Weight	Approx. 25 kg, depending on equipment
Bean hopper capacity	<ul style="list-style-type: none"> - Without bean hopper extension: 1 x 0.5 kg or 2 x 0.25 kg - With bean hopper extension: 1 x 1.1 kg or 2 x 0.55 kg
Powder hopper capacity	Powder hopper: 0.5 kg Double powder container: 2 x 0.5 kg
Water tank	4.8 l
Ambient conditions	Humidity: max. 80 % Ambient temperature: 5–32 °C
Noise emission	<70 dB(A)

14.3 Coffee machine electrical connections

Type	Voltage	Connection	Power rating	Fuse	Frequency
A300	220–240 V	1L N PE	2100–2400 W	10 A	50–60 Hz
(FCS4070)	100 V	1L N PE	1400 W	15 A	50–60 Hz
	110–127 V	1L N PE	1200–1500 W	15 A	60 Hz

INDEX

Numeric

5-step method 10, 46

A

Ambient conditions 59

B

Bean hopper 59

C

Cancel button 13

Capacities 59

Cleaning 47

Cleaning tablets 15

Coffee machine

 Cleaning 47

 unpacking 25

Connect the water supply 26

Connection

 electrical 27, 59

D

Dashboard 11

E

Error message

 Color code 14

 Depiction 14

I

Intended use 5

M

Manual set 15

Milk system cleaning agent

 Dosing bottle 15

N

Noise emission 59

O

Operating mode

 Quick Select 20

P

Powder hopper 59

Power connection 59

R

Requirements 10

S

Safety 6

Scope of delivery

 Manual set 15

Start button 13

Symbols 10

 Dashboard 11

 Instructions 11

 Software 11

T

Tips 10

U

User manual 15

W

Wastewater 27

Water tank 59

 Filling 40

 Inserting 40

MAKE IT
Wonderful!



Franke Kaffeemaschinen AG

Franke-Str. 9
CH-4663 Aarburg

Switzerland

Hotline-Phone: +41 62 787 37 37

Fax: +41 62 787 97 37

Internet www.franke.com

FRANKE