

Wall-site display case plug-in or remote controlled at ventilated refrigeration (RV), for the display of dairy products and fresh pre-packed products. Double glazed doors equipped with automatic closer. LED lighting on the sides and front middle vertical post. Height adjustable feel. Adjustable shelves with rack system.

Espositore murale plug-in o predisposto per unità remota a refrigerazione ventilata (RV), per l'esposizione di formaggi, latticini e prodotti freschi preconfezionati. Porte in vetro camera dotate di chiusura automatica. Illuminazione a LED verticali posta frontalmente nei fianchi e in prossimità del montante intermedio. Basamento con piedini regolabili in altezza. Ripiani regolabili in altezza con sistema a cremagliera.

Standard equipment

Shelves [5] - RAL 7038

Panoramic side panels
[Internal/External colours RAL 7038]

Electronic control board

LED internal lighting

Automatic system for evaporation of
condensing water [foreseen only with
compressor built in unit]

Dotazioni di serie

Ripiani [5] - RAL 7038

Fianchi panoramici
[colore Interno/Esterno RAL 7038]

Quadro comandi elettronico

Illuminazione interna LED su montanti verticali

Sistema automatico evaporazione acqua
di condensa [previsto solo con unità
condensatrice a bordo]



ENERGY SAVING
LED / Camera glass doors



INSTALLATION
Plug-in



TEMPERATURE
-1/+4 °C



DEFROST
Off Cycle



CLIMATIC CLASS
3



Slim GD Catalog - Catalogo

Model Modello	Code Codice		Condensing unit included Unità condensatrice a bordo		Condensing unit not included Senza unità condensatrice a bordo	Remote condensing unit Unità condensatrice remota			
	R404A	R744	R404A Air / Aria	R744 Air / Aria	R404A	R404A Air / Aria 0-7 mt 230V/1Ph/50Hz	R404A Air / Aria 0-35 mt 400V/3Ph/50Hz		
RV	TN	100	SLM1100100L	SLM2100100L	*****	*****	*****	*****	*****
		130	SLM1130100L	SLM2130100L	*****	*****	*****	*****	*****
		190	SLM1190100L	SLM2190100L	*****	*****	*****	*****	*****

Slim GD Technical features - Caratteristiche tecniche

	100	130	190
External dimensions [LxDxH] Dimensioni esterne [LxPxH]	986 X 645 X 2050 mm	1226 x 645 x 2050 mm	1886 x 645 x 2050 mm
Capacity [gross/net] Capacità [lorda/netta]	790/345 lt	995/435 lt	1515/685 lt
Net weight Peso netto	235 kg	282 kg	398 kg
Refrigeration Refrigerazione	Ventilated - Ventilata		
Refrigerant Refrigerante	R404A ^[1] - R744 ^[2]		
Climatic class Classe climatica	3		
Operating conditions Condizioni ambientali	25 °C / 60 %RH		
Product temperature Temperatura prodotto	-1/ +4 °C		
Compressor [q.ty-type] Compressore [q.tà-tipologia]	1 Hermetic - 1 Ermetico		
Defrost Sbrinamento	Fermata compressore - Off cycle		
Power supply Alimentazione	230 V / 1 Ph / 50 Hz		
Electrical input (standard) Assorbimento elettrico	^[1] 670 W / 3.7 A	^[2] 800 W / 3.6 A	^[1] 700 W / 3.9 A
			^[2] 850 W / 3.8 A
			^[1] 1350 W / 7.4 A
			^[2] 1600 W / 7.2 A
Electrical input (defrost) Assorbimento elettrico	150 W / 0.8 A		300 W / 1.7 A
Cooling capacity required Richieste frigorifere	FV -2 °C	-	-
	SL -3 °C	-	-
	MT -5 °C	-	-

Internal Interno	External Esterno	Shelf (1) Ripiano (1)	LED shelves lighting (1) Illuminazione ripiani LED (1)	Without side [joining kit] Senza fianchi [canalizzazione]
Inox	Inox	RAL 7038	Inox	

+ *****	+ *****	*****	*****	*****	*****
+ *****	+ *****	*****	*****	*****	*****
+ *****	+ *****	*****	*****	*****	*****

Panoramic side panels (2) Fianchi panoramici (2)	Mirror side panels (2) Fianchi a specchio (2)
Inox	RAL 7038 Optional RAL
	Inox

100	+ *****	+ *****	+ *****
130	+ *****	+ *****	+ *****
190	+ *****	+ *****	+ *****

Section - Sezioni

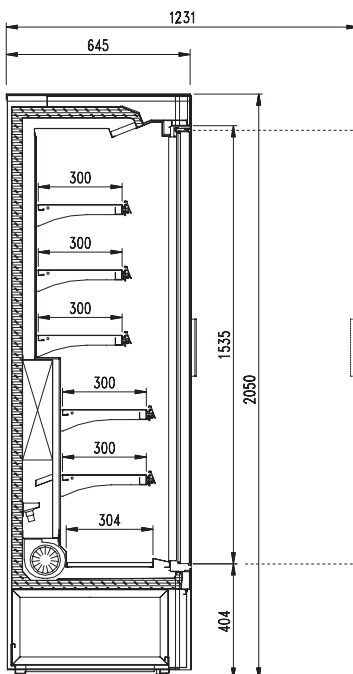

Slim **GD** **Optionals** - Elementi opzionali

Item	Accessorio	Model Modello	Quantity Quantità	Code Codice	Unitary Price Prezzo unitario
Divider	Divisorio	-		9004990100801	*****
Shelf riser	Frontalino ripiano	100	1	9004990101400	*****
		130	1	9004990100802	*****
		190	2	9004990101400	*****

Slim **Customizable area** - Aree personalizzabili

Sticker Adesivo

Mod. 100 940 x 93 H

Mod. 130 1180 x 93 H

Mod. 190 1840 x 93 H

