

Galaxy



Galaxy Open

H 205
P 88
L 94 • 125 • 188



Galaxy SGD

H 205
P 88
L 94 • 125 • 188



Galaxy H150 Open

H 151
P 88
L 94 • 125 • 188



Galaxy H150 SLD

H 151
P 88
L 94 • 125 • 188



Galaxy GD

H 205
P 88
L 94 • 125 • 188



Galaxy Smartflex

H 205
P 88
L 94 • 125 • 188



Galaxy TB

H 205
P 84
L 1P • 2P • 3P



Galaxy H150 TB GD

H 207
P 88,5
L 67 • 134 • 201

Galaxy Open

H 205
P 88
L 94 • 125 • 188

sandwiches • drinks • dairy • fresh products

	TN Chiller	TB Freezer	TB/TN Chiller Freezer	TCS Heated	TCB Bain Marie
RS-Static					
RV-Ventilated	•				
TC-Heated					
HUR-Meat					
CH-Chocolate					

Multiplexable wall-site multideck chiller, for the display of dairy products, fresh and pre-packed products

Installation

Plug-in (remote version available)

Climate and product class

3M2

Temperature range

+2 / +4 °C

Refrigerant

R290

Refrigeration

Ventilated

Defrost

Compressor off

Illumination

- LED lighting on canopy
- Undershelf LED lighting optional

Side Panels

- Panoramic with safety glass
- Mirrored
- Blind

Shelves

5 (illumination optional)

Closing system

Self-rolling curtain (optional)

Base

4 adjustable feet wheels optional

Espositore murale canalizzabile per l'esposizione di formaggi, latticini e prodotti freschi preconfezionati.

Installazione

Plug-in (versione remotizzata disponibile)

Classe climatica e di prodotto

3M2

Temperatura di esercizio

+2 / +4 °C

Refrigerante

R290

Refrigerazione

Ventilata

Sbrinamento

Fermata compressore

Illuminazione

- LED superiore
- Illuminazione ripiani optional

Fianchi

- Panoramici con vetro temprato
- Specchio
- Ciechi

Ripiani

5 (illuminazione optional)

Sistema di chiusura

Tenda autoavvolgente manuale (optional)

Basamento

4 piedini regolabili ruote optional



Inside color

Colori interno

- RAL optional
- S/S optional

Outside color

Colore esterno

- RAL optional
- S/S optional

Side panels color

Colori fianchi

- RAL optional
- S/S optional

Galaxy Open

	94	125	188
External dimensions (LxDxH) (with panoramic sides) (1) Dimensioni esterne (LxPxH) (con spalle panoramiche)	993 x 875 x 2050 mm	1300 x 875 x 2050 mm	1935 x 875 x 2050 mm
External dimensions (LxDxH) (with mirror/blind sides) (2) Dimensioni esterne (LxPxH) (con spalle cieche/specchio)	1011 x 875 x 2050 mm	1318x 875 x 2050 mm	1953 x 875 x 2050 mm
Capacity (gross/net) Capacità (lorda/netta)	767/456 lt	970/582 lt	1526/928 lt
Net weight Peso netto	240 kg	295 kg	425 kg
Refrigeration Refrigerazione	Ventilated - Ventilata		
Refrigerant Refrigerante	R290		
Climatic class Classe climatica	3		
Operating conditions Condizioni ambientali	25 °C / 60 %RH		
Temperature range Temperatura di esercizio	+2 / +4 °C		
Product temperature Temperatura prodotto	-1 / +7 °C		
Compressor (q.ty-type) Compressore (q.tà-tipologia)	1 Hermetic - 1 Ermetico		
Defrost Sbrinamento	Off cycle - Fermata compressore		
Power supply Alimentazione	230 V / 1 Ph / 50 Hz		
Cooling capacity required Richieste frigorifere	-		

1) Panoramic side panels are 25 mm thick / 2) Blind side panels are 34 mm thick

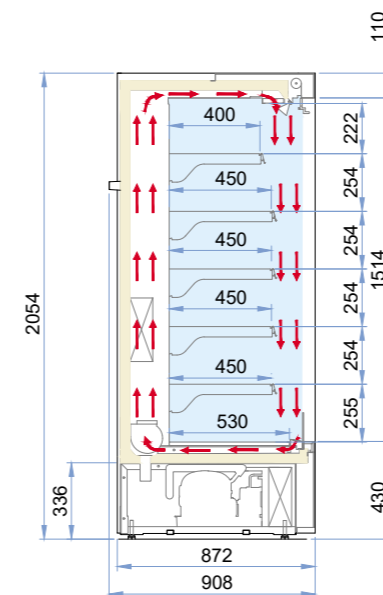

Galaxy SGD

H 205
P 88
L 94 • 125 • 188

meat • sandwiches • drinks •
dairy • fresh products

	TN Chiller	TB Freezer	TB/TN Chiller Freezer	TCS Heated	TCB Bain Marie
RS-Static					
RV-Ventilated	•				
TC-Heated					
HUR-Meat					
CH-Chocolate					

Multiplexable wall-site
 multideck chiller, for the display
 of dairy products, fresh
 and pre-packed products

Installation
 Plug-in (remote version
 available)

**Climate
 and product class**
 3M1

Temperature range
 0 / +2 °C

Refrigerant
 R290

Refrigeration
 Ventilated

Defrost
 Compressor off

Illumination
 • LED lighting on canopy
 • Undershelf LED lighting
 optional

Side Panels
 • Panoramic
 with safety glass
 • Mirrored
 • Blind

Shelves
 5 (illumination optional)

Closing system
 Single glass doors

Base
 4 adjustable feet
 wheels optional

Espositore murale canalizzabile
 per l'esposizione di formaggi,
 latticini e prodotti freschi
 preconfezionati.

Installazione
 Plug-in (versione remotizzata
 disponibile)

**Classe climatica
 e di prodotto**
 3M1

Temperatura di esercizio
 0 / +2 °C

Refrigerante
 R290

Refrigerazione
 Ventilata

Sbrinamento
 Fermata compressore

Illuminazione
 • LED superiore di serie
 • LED sui ripiani
 optional

Fianchi
 • Panoramici
 con vetro temprato
 • Specchio
 • Ciechi

Ripiani
 5 (illuminazione optional)

Sistema di chiusura
 Porte in vetro singolo

Basamento
 4 piedini regolabili
 ruote optional



Inside color
 Colori interno

RAL optional
 S/S optional

Outside color
 Colore esterno

RAL optional
 S/S optional

Side panels color
 Colori fianchi

RAL optional
 S/S optional

Galaxy SGD

	94	125	188
External dimensions (LxDxH) (with panoramic sides) Dimensioni esterne (LxPxH) (con spalle panoramiche)	993 x 875 x 2050 mm	1300 x 875 x 2050 mm	1935 x 875 x 2050 mm
External dimensions (LxDxH) (with mirror/blind sides) Dimensioni esterne (LxPxH) (con spalle cieche/specchio)	1011 x 875 x 2050 mm	1318x 875 x 2050 mm	1953 x 875 x 2050 mm
Capacity (gross/net) Capacità (lorda/netta)	767/456 lt	970/582 lt	1526/928 lt
Net weight Peso netto	285 kg	345 kg	485 kg
Refrigeration Refrigerazione	Ventilated - Ventilata		
Refrigerant Refrigerante	R290		
Climatic class Classe climatica	3		
Operating conditions Condizioni ambientali	25 °C / 60 %RH		
Temperature range Temperatura di esercizio	0 / +2 °C		
Product temperature Temperatura prodotto	-1 / +5 °C		
Compressor (q.ty-type) Compressore (q.tà-tipologia)	1 Hermetic - 1 Ermetico	2 Hermetic - 2 Ermetico	
Defrost Sbrinamento	Off cycle - Fermata compressore		
Power supply Alimentazione	230 V / 1 Ph / 50 Hz		

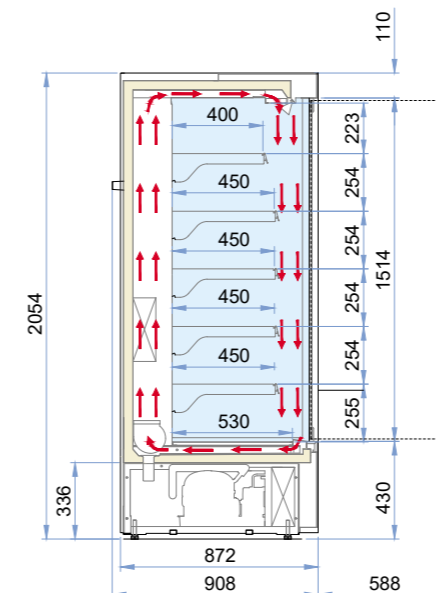

Galaxy GD

H 205
P 88
L 94 • 125 • 188

meat • sandwiches • drinks •
dairy • fresh products

	TN Chiller	TB Freezer	TB/TN Chiller Freezer	TCS Heated	TCB Bain Marie
RS-Static					
RV-Ventilated	•				
TC-Heated					
HUR-Meat					
CH-Chocolate					

Multiplexable wall-site
multideck chiller, for the display
of dairy products, fresh and
pre-packed products

Installation
Plug-in (remote version
available)

**Climate
and product class**
3M0

Temperature range
-1 / +1 °C

Refrigerant
R290

Refrigeration
Ventilated

Defrost
Compressor off

Illumination
• LED lighting on canopy
• Vertical and undershelf
LED lighting optional

Side Panels
• Panoramic
with safety glass
• Mirrored
• Blind

Shelves
5 (illumination optional)

Closing system
Double glass doors

Base
4 adjustable feet
wheels optional

Espositore murale canalizzabile
per l'esposizione di formaggi,
latticini e prodotti freschi
preconfezionati.

Installazione
Plug-in (versione remotizzata
disponibile)

**Classe climatica
e di prodotto**
3M0

Temperatura di esercizio
-1 / +1 °C

Refrigerante
R290

Refrigerazione
Ventilata

Sbrinamento
Fermata compressore

Illuminazione
• LED superiore di serie
• LED verticale e sui ripiani
optional

Fianchi
• Panoramici
con vetro temprato
• Specchio
• Ciechi

Ripiani
5 (illuminazione optional)

Sistema di chiusura
Porte in vetro camera

Basamento
4 piedini regolabili
ruote optional



Inside color
Colori interno

RAL optional
S/S optional

Outside color
Colore esterno

RAL optional
S/S optional

Side panels color
Colori fianchi

RAL optional
S/S optional

Galaxy GD

	94	125	188
External dimensions (LxDxH) (with panoramic sides) Dimensioni esterne (LxPxH) (con spalle panoramiche)	993 x 875 x 2050 mm	1300 x 875 x 2050 mm	1935 x 875 x 2050 mm
External dimensions (LxDxH) (with mirror/blind sides) Dimensioni esterne (LxPxH) (con spalle cieche/specchio)	1011 x 875 x 2050 mm	1318 x 875 x 2050 mm	1953 x 875 x 2050 mm
Capacity (gross/net) Capacità (lorda/netta)	767/456 lt	970/582 lt	1526/928 lt
Net weight Peso netto	285 kg	345 kg	485 kg
Refrigeration Refrigerazione	Ventilated - Ventilata		
Refrigerant Refrigerante	R290		
Climatic class Classe climatica	3		
Operating conditions Condizioni ambientali	25 °C / 60 %RH		
Temperature range Temperatura di esercizio	-1 / +1 °C		
Product temperature Temperatura prodotto	-1 / +4 °C		
Compressor (q.ty-type) Compressore (q.tà-tipologia)	1 Hermetic - 1 Ermetico	2 Hermetics - 2 Ermetici	
Defrost Sbrinamento	Off cycle - Fermata compressore		
Power supply Alimentazione	230 V / 1 Ph / 50 Hz		

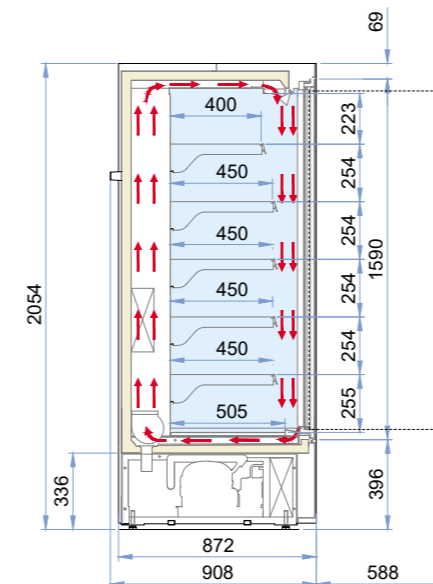

Galaxy Smartflex

H 205
P 88
L 94 • 125 • 188

meat • sandwiches • drinks •
dairy • fresh products

	TN Chiller	TB Freezer	TB/TN Chiller Freezer	TCS Heated	TCB Bain Marie
RS-Static					
RV-Ventilated	•				
TC-Heated					
HUR-Meat					
CH-Chocolate					

Multiplexable wall-site
 multideck chiller, for the display
 of dairy products, fresh and
 pre-packed products

Installation
 Plug-in (remote version
 available)

**Climate
 and product class**
 3M1

Temperature range
 0 / +2 °C

Refrigerant
 R290

Refrigeration
 Ventilated

Defrost
 Compressor off

Illumination
 • LED lighting on canopy
 • Undershelf LED lighting
 optional

Side Panels
 • Panoramic
 with safety glass
 • Mirrored
 • Blind

Shelves
 5 (illumination optional)

Closing system
 Smartflex

Base
 4 adjustable feet
 wheels optional

Espositore murale canalizzabile
 per l'esposizione di formaggi,
 latticini e prodotti freschi
 preconfezionati.

Installazione
 Plug-in (versione remotizzata
 disponibile)

**Classe climatica
 e di prodotto**
 3M1

Temperatura di esercizio
 0 / +2 °C

Refrigerante
 R290

Refrigerazione
 Ventilata

Sbrinamento
 Fermata compressore

Illuminazione
 • LED superiore di serie
 • LED sui ripiani
 optional

Fianchi
 • Panoramici
 con vetro temprato
 • Specchio
 • Ciechi

Ripiani
 5 (illuminazione optional)

Sistema di chiusura
 Smartflex

Basamento
 4 piedini regolabili
 ruote optional



Inside color
 Colori interno

RAL optional
 S/S optional

Outside color
 Colore esterno

RAL optional
 S/S optional

Side panels color
 Colori fianchi

RAL optional
 S/S optional

Galaxy Smartflex

	94	125	188
External dimensions (LxDxH) (with panoramic sides) Dimensioni esterne (LxPxH) (con spalle panoramiche)	993 x 875 x 2050 mm	1300 x 875 x 2050 mm	1935 x 875 x 2050 mm
External dimensions (LxDxH) (with mirror/blind sides) Dimensioni esterne (LxPxH) (con spalle cieche/specchio)	1011 x 875 x 2050 mm	1318 x 875 x 2050 mm	1953 x 875 x 2050 mm
Capacity (gross/net) Capacità (lorda/netta)	596/355 lt	754/453 lt	1129/665 lt
Net weight Peso netto	285 kg	345 kg	485 kg
Refrigeration Refrigerazione	Ventilated - Ventilata		
Refrigerant Refrigerante	R290		
Climatic class Classe climatica	3		
Operating conditions Condizioni ambientali	25 °C / 60 %RH		
Temperature range Temperatura di esercizio	0 / +2 °C		
Product temperature Temperatura prodotto	-1 / +5 °C		
Compressor (q.ty-type) Compressore (q.tà-tipologia)	1 Hermetic - 1 Ermetico	2 Hermetics - 2 Ermetici	
Defrost Sbrinamento	Off cycle - Fermata compressore		
Power supply Alimentazione	230 V / 1 Ph / 50 Hz		

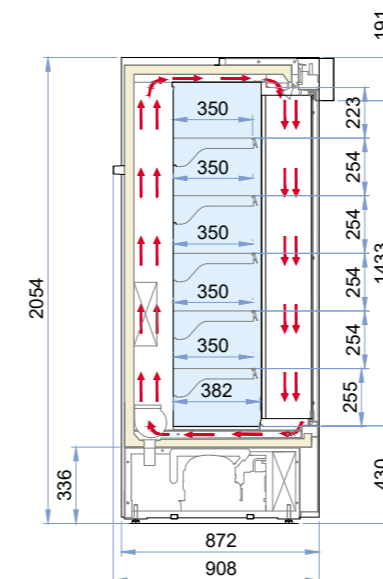

Galaxy H150 Open

H 151
P 88
L 94 • 125 • 188

sandwiches • drinks • dairy • fresh products

	TN Chiller	TB Freezer	TB/TN Chiller Freezer	TCS Heated	TCB Bain Marie
RS-Static					
RV-Ventilated	•				
TC-Heated					
HUR-Meat					
CH-Chocolate					

Multiplexable multideck chiller, for the display of dairy products, fresh and pre-packed products

Installation
Plug-in (remote version available)

Climate and product class
3M1

Temperature range
0 / +2 °C

Refrigerant
R290

Refrigeration
Ventilated

Defrost
Compressor off

Illumination
• LED lighting on canopy
• Undershelf LED lighting optional

Side Panels
• Panoramic with safety glass
• Mirrored
• Blind

Shelves
3 (illumination optional)

Closing system
Self-rolling curtain (optional)

Base
4 adjustable feet wheels optional

Espositore semi-murale canalizzabile per l'esposizione di formaggi, latticini e prodotti freschi confezionati.

Installazione
Plug-in (versione remotizzata disponibile)

Classe climatica e di prodotto
3M1

Temperatura di esercizio
0 / +2 °C

Refrigerante
R290

Refrigerazione
Ventilata

Sbrinamento
Fermata compressore

Illuminazione
• LED superiore
• Illuminazione ripiani optional

Fianchi
• Panoramici con vetro temprato
• Specchio
• Ciechi

Ripiani
3 (illuminazione optional)

Sistema di chiusura
Tenda autoavvolgente manuale (optional)

Basamento
4 piedini regolabili ruote optional



Inside color
Colori interno

RAL optional
S/S optional

Outside color
Colore esterno

RAL optional
S/S optional

Side panels color
Colori fianchi

RAL optional
S/S optional

Galaxy Open

	94	125	188
External dimensions (LxDxH) (with panoramic sides) Dimensioni esterne (LxPxH) (con spalle panoramiche)	993 x 875 x 1510 mm	1300 x 875 x 1510 mm	1935 x 875 x 1510 mm
External dimensions (LxDxH) (with mirror/blind sides) Dimensioni esterne (LxPxH) (con spalle cieche/specchio)	1011 x 875 x 1510 mm	1318 x 875 x 1510 mm	1953 x 875 x 1510 mm
Capacity (gross/net) Capacità (lorda/netta)	491/386 lt	651/ 512 lt	983 / 773 lt
Net weight Peso netto	200 kg	240 kg	340 kg
Refrigeration Refrigerazione	Ventilated - Ventilata		
Refrigerant Refrigerante	R290		
Climatic class Classe climatica	3		
Operating conditions Condizioni ambientali	25 °C / 60 %RH		
Temperature range Temperatura di esercizio	+0 / +2 °C		
Product temperature Temperatura prodotto	-1 / +5 °C		
Compressor (q.ty-type) Compressore (q.tà-tipologia)	1 Hermetic - 1 Ermetico	2 Hermetics - 2 Ermetici	
Defrost Sbrinamento	Off cycle - Fermata compressore		
Power supply Alimentazione	230 V / 1 Ph / 50 Hz		

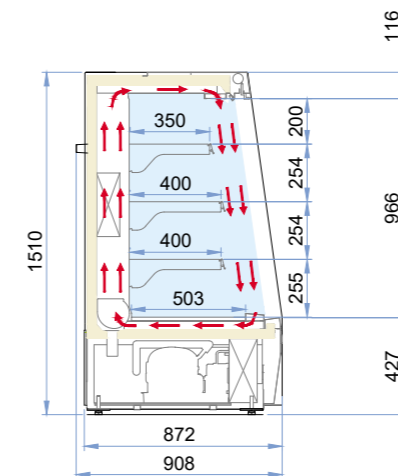

Galaxy H150 SLD

H 151
P 88
L 94 • 125 • 188

meat • sandwiches • drinks •
dairy • fresh products

	TN Chiller	TB Freezer	TB/TN Chiller Freezer	TCS Heated	TCB Bain Marie
RS-Static					
RV-Ventilated	•				
TC-Heated					
HUR-Meat					
CH-Chocolate					

Multiplexable multideck chiller, for the display of dairy products, fresh and pre-packed products

Installation
Plug-in (remote version available)

Climate and product class
3M0

Temperature range
-1 / +1 °C

Refrigerant
R290

Refrigeration
Ventilated

Defrost
Compressor off

Illumination
• LED lighting on canopy
• Undershelf LED lighting optional

Side Panels
• Panoramic with safety glass
• Mirrored
• Blind

Shelves
3 (illumination optional)

Closing system
Glass sliding doors

Base
4 adjustable feet wheels optional

Espositore semi-murale canalizzabile per l'esposizione di formaggi, latticini e prodotti freschi preconfezionati.

Installazione
Plug-in (versione remotizzata disponibile)

Classe climatica e di prodotto
3M0

Temperatura di esercizio
-1 / +1 °C

Refrigerante
R290

Refrigerazione
Ventilata

Sbrinamento
Fermata compressore

Illuminazione
• LED superiore
• Illuminazione ripiani optional

Fianchi
• Panoramici con vetro temprato
• Specchio
• Ciechi

Ripiani
3 (illuminazione optional)

Sistema di chiusura
Porte in vetro scorrevoli

Basamento
4 piedini regolabili ruote optional



Inside color
Colori interno

RAL optional
S/S optional

Outside color
Colore esterno

RAL optional
S/S optional

Side panels color
Colori fianchi

RAL optional
S/S optional

Galaxy Open / SLD

	94	125	188
External dimensions (LxDxH) (with panoramic sides) Dimensioni esterne (LxPxH) (con spalle panoramiche)	993 x 875 x 1510 mm	1300 x 875 x 1510 mm	1935 x 875 x 1510 mm
External dimensions (LxDxH) (with mirror/blind sides) Dimensioni esterne (LxPxH) (con spalle cieche/specchio)	1011 x 875 x 1510 mm	1318 x 875 x 1510 mm	1953 x 875 x 1510 mm
Capacity (gross/net) Capacità (lorda/netta)	767/456 lt	970/582 lt	1453/855 lt
Net weight Peso netto	240 kg	295 kg	425 kg
Refrigeration Refrigerazione	Ventilated - Ventilata		
Refrigerant Refrigerante	R290		
Climatic class Classe climatica	3		
Operating conditions Condizioni ambientali	25 °C / 60 %RH		
Temperature range Temperatura di esercizio	-1 / +1 °C		
Product temperature Temperatura prodotto	-1 / +4 °C		
Compressor (q.ty-type) Compressore (q.tà-tipologia)	1 Hermetic - 1 Ermetico	2 Hermetics - 2 Ermetici	
Defrost Sbrinamento	Off cycle - Fermata compressore		
Power supply Alimentazione	230 V / 1 Ph / 50 Hz		

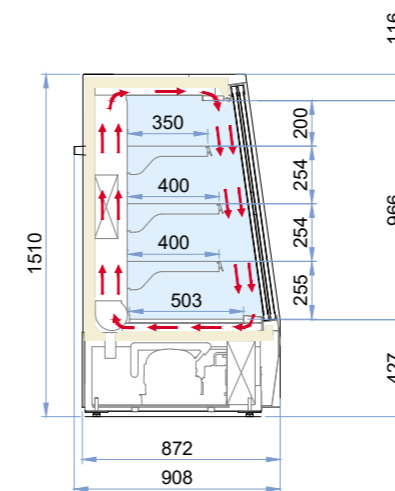

Galaxy TB

H 205
P 84
L 1P • 2P • 3P

frozen food & ice-cream

Installation
Plug-in

Configuration
5 grid shelves

Climate and product class
3L1

Temperature range
-23 / -25 °C

Refrigerant
R290

Refrigeration
Ventilated

Compressor
Hermetic

Defrost
Hot gas

Opening system
Self closing doors

Lighting
Led 5700 K

Equipment handling

- Height adjustable feet
- Swivel casters with brake

Installazione
Plug-in

Configurazione
5 mensole a griglia

Classe climatica e di prodotto
3L1

Temperatura di esercizio
-23 / -25 °C

Refrigerante
R290

Refrigerazione
Ventilata

Compressore
Ermetico

Sbrinamento
Gas caldo

Apertura
Porta con ritorno automatico

Illuminazione
Led 5700 K

Movimentazione

- Piedini regolabili in altezza
- Ruote pivotanti con freno



	TN Chiller	TB Freezer	TB/TN Chiller Freezer	TCS Heated	TCB Bain Marie
RS-Static					
RV-Ventilated		•			
TC-Heated					
HUR-Meat					
CH-Chocolate					

Inside color
Colori interno

- White (standard)
- Grey RAL 9006
- Black RAL 9005
- RAL optional

Outside color
Colore esterno

- White (standard)
- Grey RAL 9006
- Black RAL 9005
- RAL optional

Galaxy TB

	1P	2P	3P
External dimensions (LxDxH) Dimensioni esterne (LxPxH)	Piedini 668x859x2048 mm Ruote 668x859x2141 mm	1340x859x2048 mm 1340x859x2141 mm	2008x859x2048 mm 2008x859x2141 mm
Capacity (gross/net) Capacità (lorda/netta)	526 / 350 Lt	1166 / 790 Lt	1807 / 1200 Lt
Net weight Peso netto	170 kg	310 kg	490 kg
Refrigeration Refrigerazione	Ventilated Ventilata		
Refrigerant Refrigerante	R290		
Climate class Classe climatica	3		
Operating conditions Condizioni ambientali	25 °C / 60 %RH		
Temperature range Temperatura di esercizio	-23 / -25 °C		
Product temperature Temperatura prodotto	-18 / -16 °C		
Compressor (q.ty - type) Compressore (q.tà - tipologia)	1 - Hermetic 1 - Ermetico	2 - Hermetics 2 - Ermetico1	3 - Hermetics 3 - Ermetici
Defrost Sbrinamento	Hot gas Gas caldo		
Power supply Alimentazione	230 V / 1 Ph / 50 Hz		
Electrical input (nominal) Assorbimento elettrico (regime)	1000 W / 4,8 A	2000 W / 9,5 A	3000 W / 14,3 A
Electrical input (defrost) Assorbimento elettrico (sbrinamento)	1080 W / 4,6 A	2150 W / 9,2 A	3220 W / 13,8 A

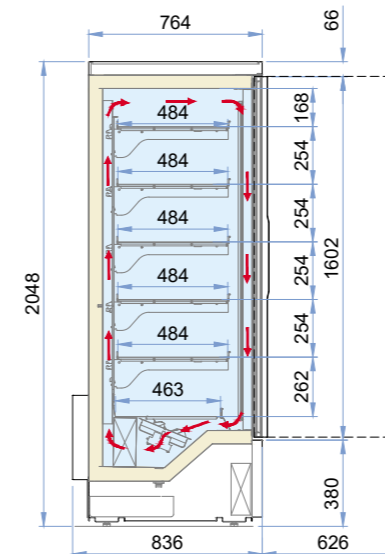

Galaxy H150 TB GD

H 207
P 88,5
L 67 • 134 • 201

frozen food & ice-cream

	TN Chiller	TB Freezer	TB/TN Chiller Freezer	TCS Heated	TCB Bain Marie
RS-Static					
RV-Ventilated		•			
TC-Heated					
HUR-Meat					
CH-Chocolate					

Installation	Installazione
Plug-in	Plug-in
Configuration Shelves 3	Configurazione 3 Mensole
Climate and product class 3L1	Classe climatica e di prodotto 3L1
Temperature range -23 / -25 °C	Temperatura di esercizio -23 / -25 °C
Refrigerant R290	Refrigerante R290
Refrigeration Ventilated	Refrigerazione Ventilata
Compressor Hermetic	Compressore Ermetico
Defrost Hot gas	Sbrinamento Gas caldo
Opening system Self closing doors	Apertura Porta con ritorno automatico
Lighting Led 5700 K	Illuminazione Led 5700 K
Equipment handling • Height adjustable feet • Swivel casters with brake	Movimentazione • Piedini regolabili in altezza • Ruote pivotanti con freno



Inside color Colori interno	Outside color Colore esterno
• White (standard)	• White (standard)
• Grey RAL 9006	• Grey RAL 9006
• Black RAL 9005	• Black RAL 9005
• RAL optional	• RAL optional
• Standard / Di serie	

Galaxy H150 TB GD

2p

External dimensions (LxDxH) Dimensioni esterne (LxPxH)	1340 x 840 x 1501
Capacity (gross/net) Capacità (lorda/netta)	625 / 485 lt
Net weight Peso netto	270 kg
Refrigeration Refrigerazione	Ventilated Ventilata
Refrigerant Refrigerante	R290
Climate class Classe climatica	3
Operating conditions Condizioni ambientali	25 °C / 60 %RH
Temperature range Temperatura di esercizio	-23 / -25 °C
Product temperature Temperatura prodotto	-18°C / -16°C
Compressor (type) Compressore (tipologia)	1 Hermetic 1 Ermetico
Defrost Sbrinamento	Hot Gas Gas Caldo
Power supply Alimentazione	230 V / 1 Ph / 50 Hz

