



# POTATO PEELER PP-12+

Output: 12 Kg. per cycle.



- ✓ Depth with stand: 700 mm
  - ✓ Height with stand: 1015 mm
- Net weight: 38 Kg

**Noise level (1m.):** 70 dB(A)  
**Background noise:** 32 dB(A)

## AVAILABLE MODELS

1000420	Potato peeler PP-12+ 230-400/50/3 ·370W
1000421	Potato peeler PP-12+ 230/50/1 ·400W
1000422	Potato peeler PP-12+ 220-380/60/3
1000423	Potato peeler PP-12+ 220/60/1
1000426	Potato peeler PP-12+ 440/60/3
1000427	Potato peeler PP-12+ 120/60/1

\* Ask for special versions availability

## SALES DESCRIPTION

Aluminium made potato peeler.

Aluminium body potato peeler. Abrasive peeling. The abrasive is highly resistant and long lasting.

- ✓ Base Plate and chamber walls lined with abrasive.
- ✓ Aluminium body.
- ✓ Directable cylinder.
- ✓ Integral control panel complete with on/off push buttons and a 0-6 minute timer.

## OPTIONAL

- Stainless steel floor stand.
- Water inlet kit (2003971).
- Filter with no-foam feature.

## ACCESSORIES

- Stands for potato peelers PP / PPC
- Filters for potato peelers PP / PPC

## SPECIFICATIONS

Hourly production: 220 Kg / 300 Kg  
 Capacity per load: 12 Kg  
 Timer (min-max): 0' - 6'  
 Plate speed: 317 rpm  
 Total loading: 400 W (1~) / 370 W (3~)

### External dimensions (WxDxH)

- ✓ Width: 395 mm
- ✓ Depth: 700 mm
- ✓ Height: 503 mm

### External dimensions with stand

- ✓ Width with stand: 411 mm

DYNAMIC PREPARATION  
COMMERCIAL POTATO PEELERS

product sheet  
updated 21/10/2022



SAMMIC, S.L.  
Bassate, 1 - 20729 Azzio/ITA  
www.sammic.com



# POTATO PEELER PP-12+

Output: 12 Kg. per cycle.



DYNAMIC PREPARATION  
COMMERCIAL POTATO PEELERS

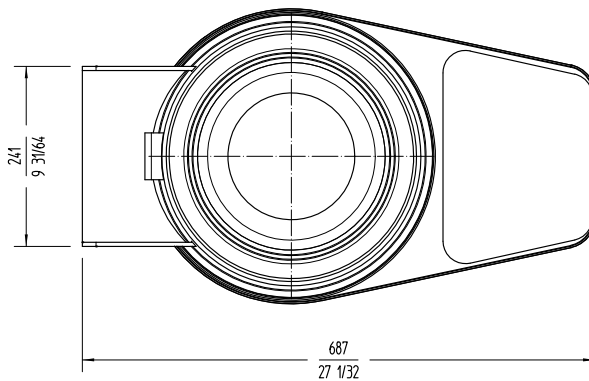
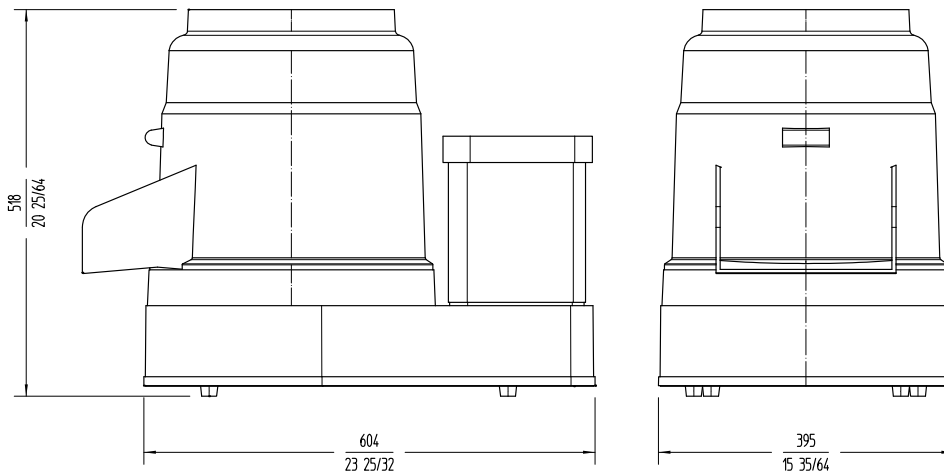

 **sammic** | [www.sammic.com](http://www.sammic.com)  
Food Service Equipment Manufacturer

Polígono Basarte, 1. phone +34 943 15 72 36  
20720 Azkoitia, Spain [sales@sammic.com](mailto:sales@sammic.com)



Project	Date
Item	Qty
Approved	

product sheet  
updated 21/10/2022