



Mxxw " z i " " w w
Nw y " " w w

T" w" w
W"y" w

Oy y " w "
O " w y y"

hy à" w "
i w à

e à w wxw "
O à. à w

d / w" 0
d "/ w0

Oww " y "

4h " " w " w" 877
4O MhV: 7<
4hx w " wTw ywz " " w " ° ww
4O i y zwB
4S " " EMxw " e 3
c"àw 3O 3h w O y" 3
hy à" w " 3O " w " 3Oy T" w 3
e à w " wk 3g" ww
UMOOe
4V w " "z" w " zw y khN
4k y z" w " yw" ww
4h zw z
4ew " " w w y

d

4hw w " vz d
4O z" w " vz vy w
4l " wA7 U
4h" wk y z" w "
4k y z" w " ww
4e wv à w/i " 0
4h"y zw zw z



S" w "

4i y " w w 877
4MhV: 7< w " " y y
4U àw z" ° à w z" ° y" z" w
4B i y y
4S y w w wk " ENw y à 3h y
" " à 3h y " " à y 3h y
O y" 3i w à 3O " w 3y" y" w
y y" 3h wk " y y" à w 3UMOOe "
ww
4k vz w z P vz zw w khN
4O z" à x
4O "/ z y 0 x"
4S w z w y z" z

d w

4d " w w
4mw" y " z y z" "
4A7 U
4m y z" à
4h z ° y z" à
4Mz wz / w à 0
4h"y z y "/ z y 0 x"

Ow wy 4Ow wy

t aNFRdN 9B7
2D7 O → 2: O

9@7
2D7 O → 48CO

t aNFUNN : D7
2D7 O → 2: O

: A@
2D7 O → 48CO



e" z
y " " rAkn
e" z " z rAkn
y " y



Oww " y " 4S" w "

O zy" e z O z" x"	f z MDAGOD	f z MD/ DD	f z MD gzAg
M " w " R" ywe "	<77l 6 c 6@7Up	<77l 6 c 6@7Up	9: 7l 6c 6@7Up
a à " w" " wd z" " à	8BC7	8BC7	8BC7
e ° z p"	8BD7	8BD7	8BD7
M" w" " wU" à	9<87	9<87	9<87
e " ww x w6 w y " " Mx x" z " 6b w O "	8: : @ m 6<DM	8C777 m 6A: M	: B77 m 68AM
Ow w " w " Owx " "	@ 873 9	@ 8A3 9	: 93@ 9
g" wxwxw " d y à /2D7 O62: O0	9B7 à	: D7 à	444
g" w à" w " d " " à /2D7 O68CO	9@7 à	: A@ à	444
Pw "z " y yw Owx " h " zww y 6 à	9<A 8B@ 8: 9 y 6BB7 à	9<A 8B@ 8: 9 y 6BB7 à	9<A 8B@ 8: 9 y 6BB7 à
Pw "z " R w 5 R w 5h " zww y 6 à	997 898 C@y 69: 7 à	997 898 C@y 69: 7 à	997 898 C@y 69: 7 à

OMgM i RgVhi YOUR kc V M gRb di M/z w w w w87 OgRb di R Odc P Rch h T kc V SRM kgR/ w z w y" 87 0

e " wS à " w g" ° à" w e " /497 O62<7 O0	8CCC7 m 4873 Ue	9BA: 7 m 48@7 Ue	
hx w " p" °	Tw Owz 4U Tw	Tw Owz 4U Tw	
P w " i x bw zww P w " " P y w à" e "	99	99	
P w " i x M w " P w " " h y e "	: @	: @	/ " wk 3D6 O k 50
P w " i x Tw Owz P w " " U Tw e "	8A	8A	
S z " ° à" w " g" ° à" w S z	g<@w 6g<7<M	g<@w 6g<7<M	
Pw "z " kO O k 5h " zww y 6 à	9: @ 8: < 8<7 /@C7 Zà 0	9: @ 8: < 8<7 /AD7 Zà 0	

z Fz

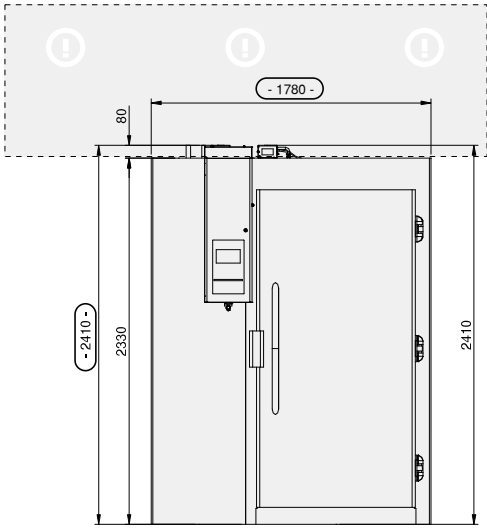

! b ww" w " w w" ww " " w à U" à ° ww "

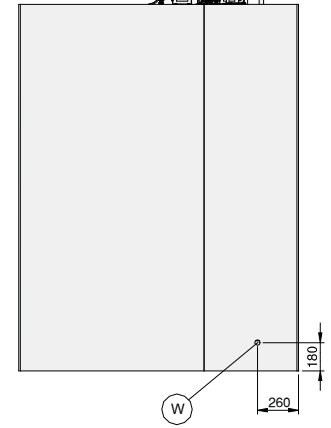
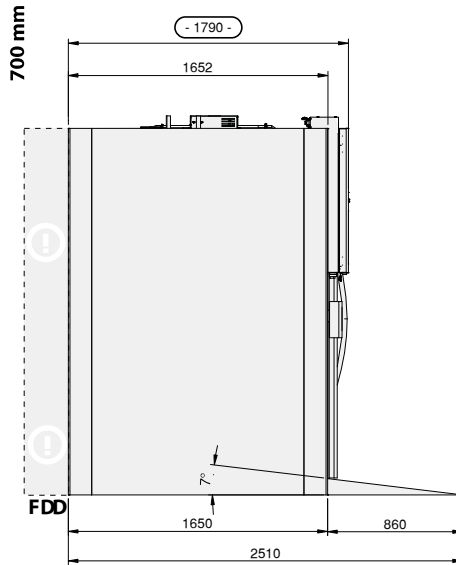

! p w x" w " y " à w " yw y wy w S " w" w° w" z w y " y

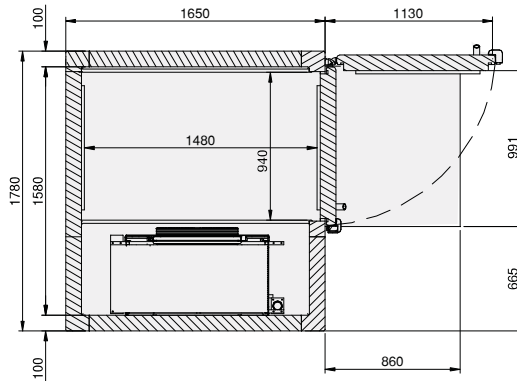
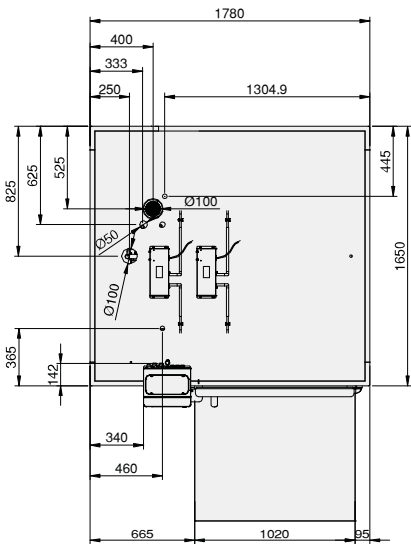

Predisposto connessione WI-FI
Predisposed WI-FI connection

Second Door Optional

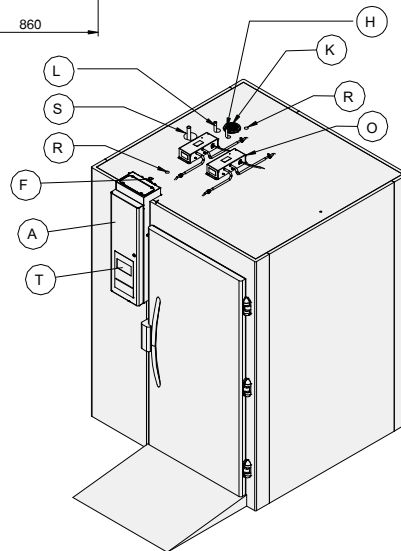
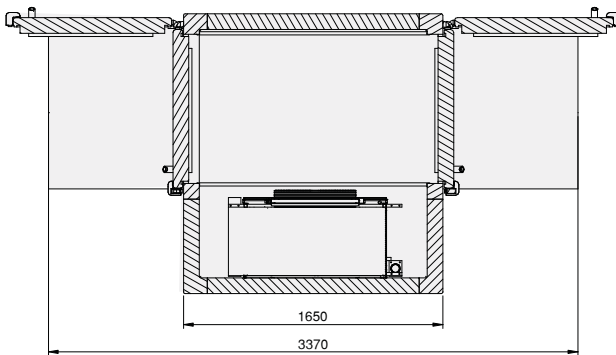

- O** Ozone Box
- H** Hot gas line
- W** Water discharge Ø 20 mm
- K** Compensation valve
- S** Suction gas line
- A** Electric Box
- R** Cables outlet
- L** Liquid line
- T** Touch Panel 7"

F WI-FI Connection



Fu

10 HP

Unità condensante
Condensing Unit

Zona collegamenti
frigoriferi ed elettrici
Refrigeration and
electrical connections
area

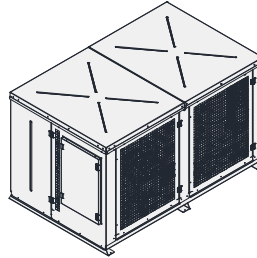
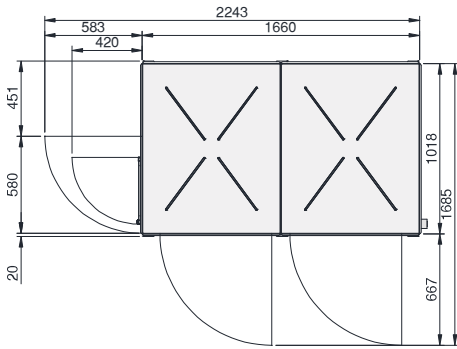
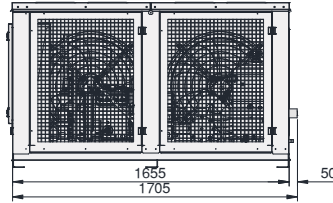
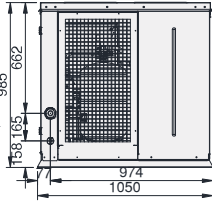

! b S " " w vy" x" 5

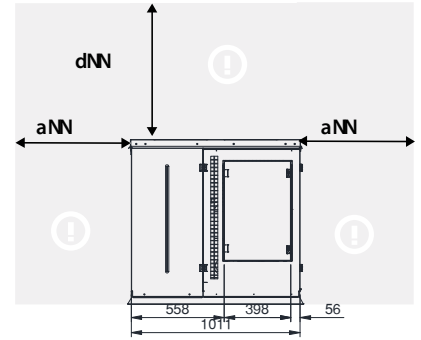

! Dimensioni indicative,
che possono cambiare,
con richieste speciali
Indicative dimensions,
which can change,
with special requests

! b S " " w vy" x" 5

15 HP

Unità condensante
Condensing Unit

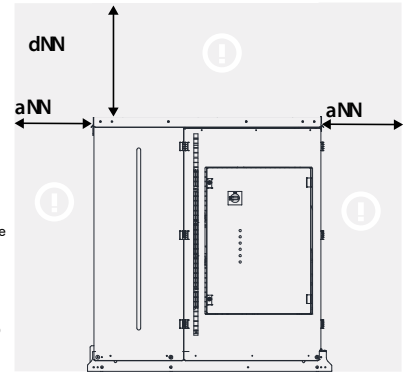
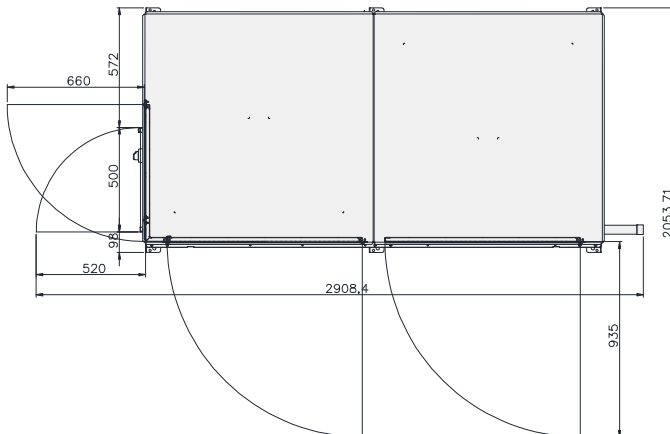
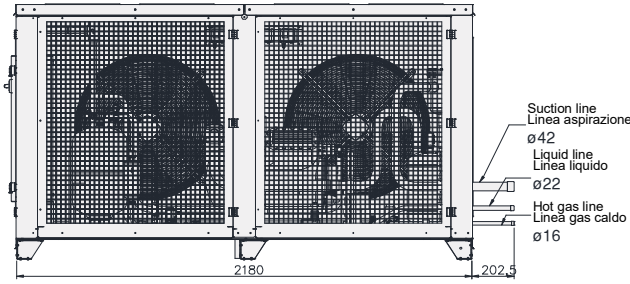
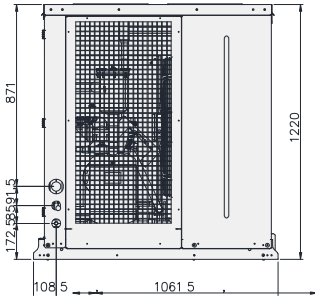

! Dimensioni indicative,
che possono cambiare,
con richieste speciali
Indicative dimensions,
which can change,
with special requests

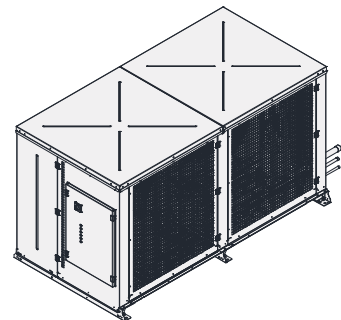

à l à

Versione Version	Abbatimento Blast chiller cycles	Ciclo gelato Ice cream cycle	Ciclo conservazione Conservation cycle	Ciclo scongelamento Thawing cycles	Ciclo Ozono Ozone cycle	Sbrinatorio gas caldo Hot gas defrosting	Programmi memorizzati Stored Programs	Ventil. Evaporatore a velocità variabile Variable speed fans evaporator	Resistenza a potenza variabile Variable power resistance	Controllo dinamico Set Dynamic Frost Control	Carico/Scarico dati-USB Load/Download data-USB
hi Mgi	●	●	●	●	●	●	●	●	●	●	●
Sk aa	●	●	●	●	●	●	●	●	●	●	●

" à u u s d u
d u " à s u"



e "z" " r4kn
y " " r4kn
e "z" "z
y "y



u F"

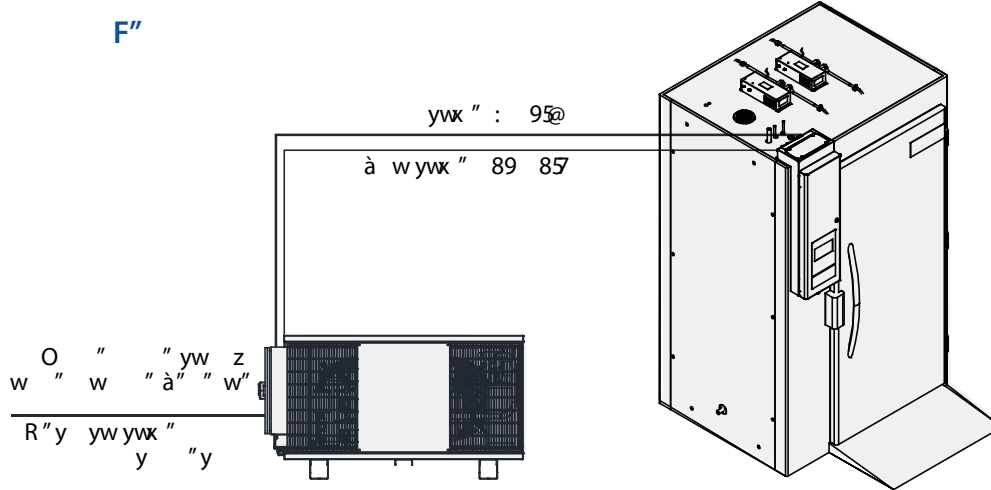

! **!**

g Ow " wy à w w y" x ° w " z" y " ° y
 . w 5h " y " z w w à w w w " w ° à " " z" w w y y 4 wy " 5V. " y z" z ° " w w " " y à ° w y" ° "
 w4 w° w " z w w w y ° y " z" w wy " 4 w° y à z w w à z " " w w y " "
 w y y w w w y" w " z " ° à w " w w y z" w z " 5V y " y " ° w y " " y" w y à " w y " "
 " z w w " " z " x " z w w y " z w " " w. à 4 y z" à 5V w y w " w w z w w à " " w y " "
 x y y z" . w 3 w " " " y w z w° w " z" w y w ° w w y 4 à ° " y" w y à " " à w
 y" w ° à " w z" w y z" w " ° w z w " 5x w " w y z" à 5J à w z" ° à w w w k " ° à w " z /
 à w y w z z " x " " " ° w w " w z à w y w z / z w w G z w y" G 9 @ 6M " w " w z" ° à w w w k " ° y w " 5
 9 @ 6 h x w " w z w w z x " z w w " z y

g 4S "à w" z y w z " y " "
 4S "à w" z y w z " w w à w y w z / " " " " 0
 4P x " à " y " z w " " y w " "à w" z w w " z w
 y z" w " 3 y " " " " z x y y w " w w y y w 5

g 4P " " " " z w k w w w ° " z à w "
 4k w " w y " " w w z " w w " 4C O 6 4 7 O
 4P x " "à w" " w w w z z / w w ° w 0
 4P x " à " y " z w " " y w " "à w" z w w " z w w
 y" w ° à " w 8 y " " " z x y y w " w w y y w

g 4Nw S " " à ° y x" z w k " z / z 0
 4k " " ° " " à " / 4C O 6 4 : 7 O R w w 0
 4d à w " z ° z " w " y / w " " z 0
 4V à w w w w k " ° à " w w w ° " y" w y à 3 y
 " w y "

t u z g
 4d à w " z ° y y " "
 4d à w " z ° y à w w " / ° " " 0
 4V à w w w w k " ° w w y à ° " y z" à 3 y
 " w y " 5

BT50 400V/3N/50Hz Blast chiller Multifunction

hyw M" w 4M" w" z R yw w

Soluzione per funzionamento minore di 16h/giorno

For running , less than 16 hours a day

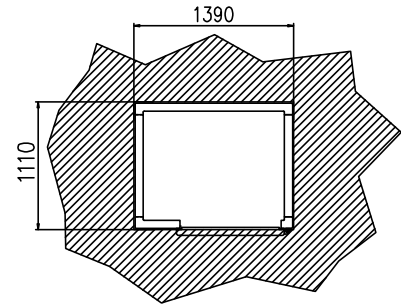
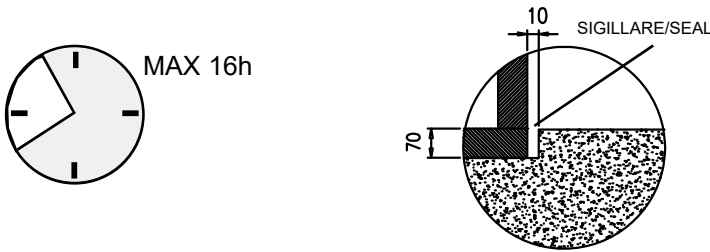

Soluzione per funzionamento 24h/giorno con griglia

For running 24 hours a day with removable grate

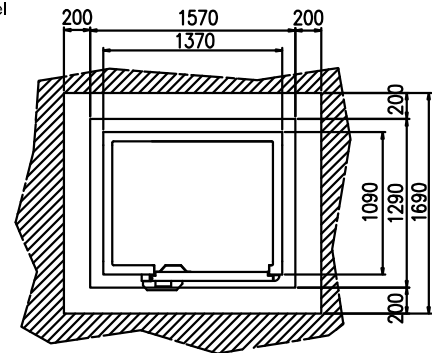
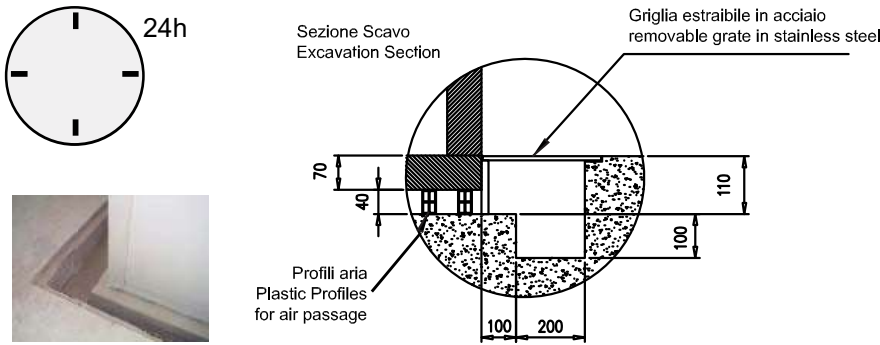

Dettaglio Scavo Excavation example

Soluzione per funzionamento 24h/giorno con camini areazione

For running 24 hours a day with ventilation chimneys

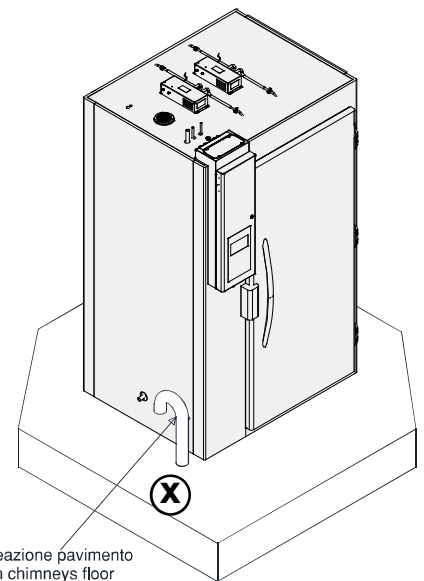
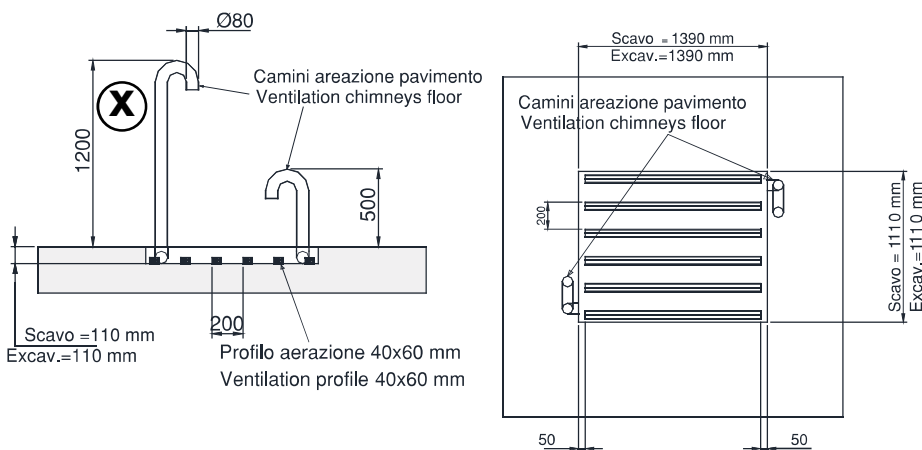

! Opere murarie e camini , a cura del cliente
Masonry work and chimneys, charged to the customer.

BT50 400V/3N/50Hz Blast chiller Multifunction

MM