

SUPER SHOW

L'EVOLUZIONE DELLA SPECIE
SPECIES EVOLUTION



L'evoluzione della specie.

Non è importante dove siamo arrivati, quello che conta è riuscire a spingersi oltre.

Dalla normalità all' avanguardia, da materiali esclusivi ed ecologici alla tecnologia del risparmio energetico.

Dalla tua creatività un arredamento unico per un locale straordinario.

ISA ti proietta nel futuro !

Species evolution.

We have surpassed the goals we have already achieved, and will continue to be at the forefront of design and technology.

From ISA, exclusive, high quality materials, unique designs, ecological awareness, energy saving technology.

From your creativity the opportunity to create unequalled designs for each individual site.

ISA gives you the future today !

Supershow rinnova i tratti genetici che hanno reso famosa la Gelatoshow, le linee ancora piu' decise e marcate la rendono ancora piu' unica. Supershow sembra avere le carte in regola per diventare la nuova stella delle vetrine per gelateria e pasticceria.

Supershow is the renewal of Gelatoshow. Its marked lines make it more unique. Supershow is the new star in Ice-Cream Parlours and Pastry Shops.



Supershow fissa i nuovi standard nel mondo del gelato.



Supershow fixes the new standards in the ice-cream world.



Supershow: il gelato come non lo avete mai visto!

Un' esposizione unica con vista tridimensionale!
Visto dall' alto come tutte le vetrine, solo Supershow permette la visione nel frontale e nei fianchi laterali per attrarre anche a notevole distanza.

Metti in mostra i tuoi capolavori come nessun altro può fare.

Supershow: the ice-cream like you have never seen it before!

Unique three-dimensional display of the ice-cream!
Supershow with its transparent front panel and side panels attracts also from far off.

Display your masterpieces like it never did before.

Progettata per una canalizzazione senza limiti e per una visione delle vaschette del gelato senza soluzioni di continuità. Un solo montante frontale permette una visione totale del gelato. I vetri sono temperati e il frontale è apribile verso il basso.

Designed to allow an unlimited number of cabinets to be multiplexed. A single front support gives a non obstructive view of the ice-cream displayed. Top opening front glass with gas supports struts.



Una infinita combinazione di moduli tecnici per gelaterie e pasticcerie, canalizzabili per qualsiasi tipo di layout per rendere ancora piu' unico il tuo locale.

A variety of technical modules (ice-cream, heated, refrigerated, neutral) all of which are multiplexable. Using this system, a display counter can be designed to suit any type of shop making your shop unequalled.



Materiali pregiati, colori raffinati e una cura per i piu' piccoli dettagli sono gli elementi base della Supershow, una vetrina che non passa inosservata.

Exclusive materials, refined colours and attention to each detail: these are the main elements of Supershow, a display cabinet that stands out from the crowd.



Una combinazione illimitata di colori che rendono unico il tuo locale.
An unlimited colour range.

FINITURE DISPONIBILI
Finishes available

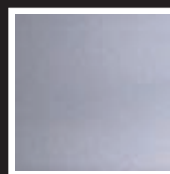

Acciaio

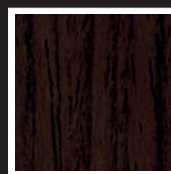

Wengè



Rosso
lacca cinese

Massima tecnologia del freddo, doppia lama d' aria per una perfetta equalizzazione della temperatura.

Supershow è equipaggiata con nuove unità condensatrici, potenti, affidabili e che riducono i consumi di energia elettrica; a richiesta disponibile con condensazione ad aria, ad acqua, miste ad aria e acqua, a bordo o remote a seconda delle tue necessità.

Con Supershow abbiamo compiuto notevoli progressi nella salvaguardia dell' ambiente, grazie ai materiali ecologici e all' utilizzo del CO2 come elemento espandente nel poliuretano iniettato ad alta densità per l' isolamento termico.

Dual cold air flow for a perfect uniformity of temperature.

Supershow has new powerful and reliable condensing units which save energy: air, water, mixed (air-water), built-in or remote to suit any requirement.

Supershow signs a big step in the environment protection thanks to ecological materials and the use of polyurethane insulation foamed with CO2.



H117

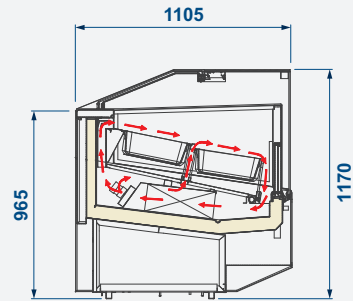

H135

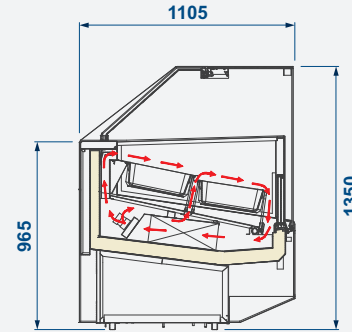

H150

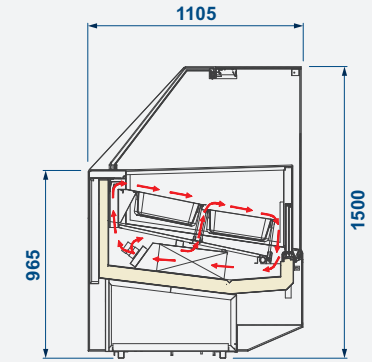

CARATTERISTICHE TECNICHE TECHNICAL FEATURES

120

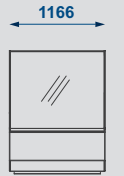

155



170



190



220



AE 45

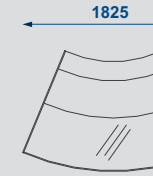

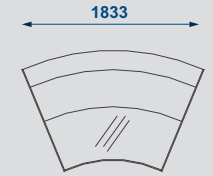

AI 45

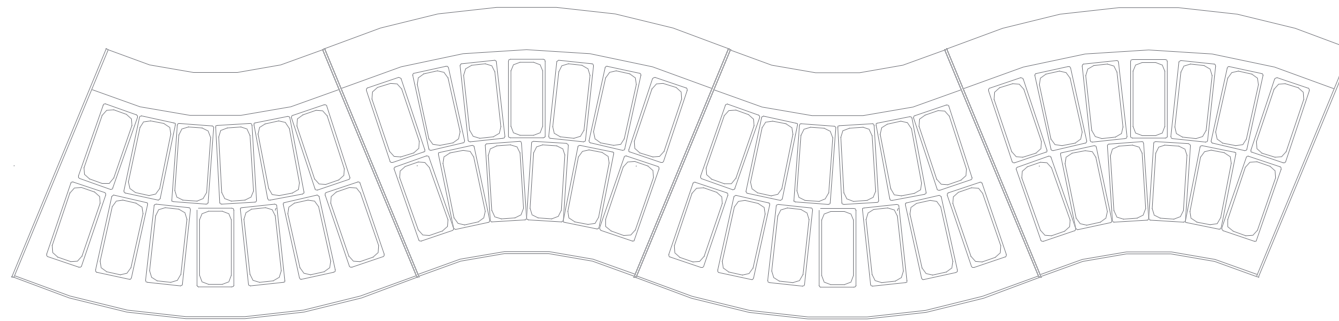

				120	155	170	190	220	AE 45	AI 45
Dimensioni esterne (lxpxh)	External dimensions (lxpxh)	mm		1166	1496	1661	1826	2156	1825	1833
			H117	1166 x 1105 x 1170	1496 x 1105 x 1170	1661 x 1105 x 1170	1826 x 1105 x 1170	2156 x 1105 x 1170	1825 x 1105 x 1170	1833 x 1105 x 1170
			H135	1166 x 1105 x 1350	1496 x 1105 x 1350	1661 x 1105 x 1350	1826 x 1105 x 1350	2156 x 1105 x 1350	1825 x 1105 x 1350	1833 x 1105 x 1350
			H150	1166 x 1105 x 1500	1496 x 1105 x 1500	1661 x 1105 x 1500	1826 x 1105 x 1500	2156 x 1105 x 1500	1825 x 1105 x 1500	1833 x 1105 x 1500
Refrigerazione	Refrigeration			VENTILATA VENTILATED	VENTILATA VENTILATED	VENTILATA VENTILATED	VENTILATA VENTILATED	VENTILATA VENTILATED	VENTILATA VENTILATED	VENTILATA VENTILATED
Capacità (lorda-netta)	Capacity (gross - net)	lt		685 / 147	901 / 193	1009 / 216	1116 / 239	1332 / 285	901 / 193	802 / 172
			H117	685 / 147	901 / 193	1009 / 216	1116 / 239	1332 / 285	901 / 193	802 / 172
			H135	824 / 147	1083 / 193	1212 / 216	1341 / 239	1600 / 285	1082 / 193	963 / 172
			H150	945 / 147	1243 / 193	1391 / 216	1540 / 239	1837 / 285	1242 / 193	1306 / 172
Temperatura di regolazione	Cabinet capacity range	°C		-20 / +2	-20 / +2	-20 / +2	-20 / +2	-20 / +2	-20 / +2	-20 / +2
Temperatura prodotto	Product temperature	°C		-16 / -14	-16 / -14	-16 / -14	-16 / -14	-16 / -14	-16 / -14	-16 / -14
Sbrinamento	Defrost			INVERSIONE DI CICLO REVERSE CYCLE	INVERSIONE DI CICLO REVERSE CYCLE	INVERSIONE DI CICLO REVERSE CYCLE	INVERSIONE DI CICLO REVERSE CYCLE	INVERSIONE DI CICLO REVERSE CYCLE	INVERSIONE DI CICLO REVERSE CYCLE	INVERSIONE DI CICLO REVERSE CYCLE
Classe climatica	Climatic class	N°		4	4	4	4	4	4	4
Condizioni ambientali	Operating conditions	°C / %RH		30 / 55	30 / 55	30 / 55	30 / 55	30 / 55	30 / 55	30 / 55
Compressore	Compressor	Tipo type		SEMIERMETICO SEMI-HERMETIC	SEMIERMETICO SEMI-HERMETIC	SEMIERMETICO SEMI-HERMETIC	SEMIERMETICO SEMI-HERMETIC	SEMIERMETICO SEMI-HERMETIC	SEMIERMETICO SEMI-HERMETIC	SEMIERMETICO SEMI-HERMETIC
		N°		1	1	1	1	1	1	1
Alimentazione	Power supply	V / ph / Hz		400 / 3 / 50	400 / 3 / 50	400 / 3 / 50	400 / 3 / 50	400 / 3 / 50	400 / 3 / 50	400 / 3 / 50
Assorbimento elettrico (regime)	Electrical input (standard)	W / A		1740 / 3.1	2470 / 6.3	2780 / 6.8	3600 / 9.7	3950 / 9.9	2300 / 5.5	2000 / 5
Assorbimento elettrico (sbrinamento)	Electrical input (defrost)	W / A		3260 / 7.9	3870 / 8.5	4250 / 9.6	4600 / 10.8	5040 / 11.4	3600 / 8.5	3300 / 8
Peso netto	Net weight	kg	H117	320	380	409	444	510	400	400
			H135	331	390	419	454	520	410	410
			H150	342	400	429	464	530	420	420



COMPONIBILITÀ VASCHE
CONTAINERS ARRANGEMENT

		120	155	170	190	220	AE 45	AI 45
<p>■ Lt 5 (360x165x120H)</p> 	12	16	18	20	24	13	13	
<p>■ Lt 5 (360x250x80H)</p> 	8	10	12	12	16	9	9	
<p>■ Lt 5 (360x185x120H) TRAPEZOIDALI</p> 						14	14	

H117

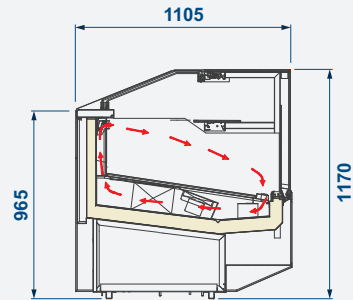

H135

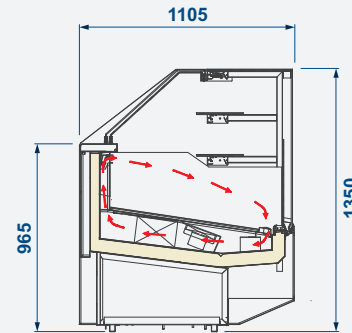

H150

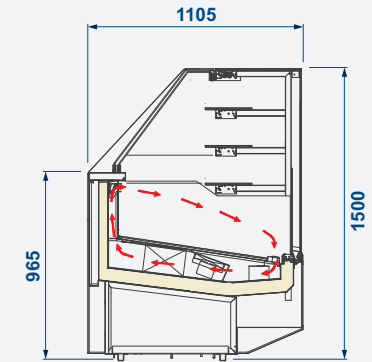

CARATTERISTICHE TECNICHE TECHNICAL FEATURES

			120	170	220	AE 45	AI 45
			1166	1661	2156	1825	1833
Dimensioni esterne (lxpxh)	External dimensions (lxpxh)	mm	H117 1166 x 1105 x 1170	H117 1661 x 1105 x 1170	H117 2156 x 1105 x 1170	H117 1825 x 1105 x 1170	H117 1833 x 1105 x 1170
			H135 1166 x 1105 x 1350	H135 1661 x 1105 x 1350	H135 2156 x 1105 x 1350	H135 1825 x 1105 x 1350	H135 1833 x 1105 x 1350
			H150 1166 x 1105 x 1500	H150 1661 x 1105 x 1500	H150 2156 x 1105 x 1500	H150 1825 x 1105 x 1500	H150 1833 x 1105 x 1500
Refrigerazione	Refrigeration		VENTILATA VENTILATED	VENTILATA VENTILATED	VENTILATA VENTILATED	VENTILATA VENTILATED	VENTILATA VENTILATED
Capacità (lorda-netta)	Capacity (gross - net)	lt	H117 685 / 267	H117 1009 / 393	H117 1332 / 518	H117 901 / 193	H117 802 / 172
			H135 824 / 267	H135 1212 / 393	H135 1600 / 518	H135 1082 / 193	H135 963 / 172
			H150 945 / 267	H150 1391 / 393	H150 1837 / 518	H150 1242 / 193	H150 1306 / 172
Temperatura prodotto	Product temperature	°C	+1 / +10	+1 / +10	+1 / +10	+1 / +10	+1 / +10
Sbrinamento	Defrost		FERMATA COMPRESSORE STOP COMPRESSOR	FERMATA COMPRESSORE STOP COMPRESSOR	FERMATA COMPRESSORE STOP COMPRESSOR	FERMATA COMPRESSORE STOP COMPRESSOR	FERMATA COMPRESSORE STOP COMPRESSOR
Classe climatica	Climatic class	N°	3	3	3	3	3
Condizioni ambientali	Operating conditions	°C / %RH	25 / 60	25 / 60	25 / 60	25 / 60	25 / 60
Compressore	Compressor	Tipo type	ERMETICO HERMETIC	ERMETICO HERMETIC	ERMETICO HERMETIC	ERMETICO HERMETIC	ERMETICO HERMETIC
		N°	1	1	1	1	1
Alimentazione	Power supply	V / ph / Hz	230 / 1 / 50	230 / 1 / 50	230 / 1 / 50	230 / 1 / 50	230 / 1 / 50
Assorbimento elettrico (regime)	Electrical input (standard)	W / A	660 / 5	810 / 6	1180 / 8	660 / 5	660 / 5
Assorbimento elettrico (sbrinamento)	Electrical input (defrost)	W / A	150 / 2	200 / 2	320 / 3	150 / 2	150 / 2
Peso netto	Net weight	kg	H117 320	H117 380	H117 410	H117 444	H117 510
			H135 331	H135 390	H135 419	H135 454	H135 520
			H150 341	H150 400	H150 429	H150 464	H150 530

1 2 Headquarters and Factory



3 4 5 Logistics, Factory and Research & Development



La Supershow debutta negli showroom dei concessionari ed è visibile sul sito www.isaitaly.com con tutte le informazioni.

Supershow is in the showrooms of our concessionaires and in our site www.isaitaly.com where you can find all the information you need.

ISA S.p.A
Via del Lavoro, 5
06083 Bastia Umbra
Perugia - Italy
Tel. +39 075 80171
Fax +39 075 8000900

www.isaitaly.com



ISO 9001:2000
Cert. CISQ/CSQ 9105.ISA 1

ISO 14001:2004
Cert. CSQ/ECO ISO 9191.ISA 3



ISA utilizza per i suoi prodotti sistemi di refrigerazione con gas ecologici e sistemi d'isolamento con poliuretano privo di HCFC nel massimo rispetto dell'ambiente e dell'uomo. Tutti gli impianti elettrici sono sottoposti a severi test di sicurezza che ne verificano il perfetto funzionamento.



ISA uses: eco-friendly gases in its refrigeration systems and HCFC free polyurethane insulation systems, in keeping with its deep respect for people and the environment. All electrical systems undergo rigorous safety tests to ensure perfect operation.

C5000 - 4/09

Documento non contrattuale.
ISA S.p.A. si riserva il diritto di modificare senza preavviso caratteristiche e gamma dei prodotti citati nella presente edizione.

Non contractual document.
ISA S.p.A. reserves itself the right to modify without notice the characteristics and range of the products listed in this edition.

